

HEATER & AIR CONDITIONER

SECTION HA

CONTENTS

<div style="border: 1px solid black; display: inline-block; width: 100px; height: 15px; margin: 0 auto;"></div>	AUTO	<div style="border: 1px solid black; display: inline-block; width: 100px; height: 15px; margin: 0 auto;"></div>	
PRECAUTIONS			3
Supplemental Restraint System (SRS) "AIR BAG" and "SEAT BELT PRE-TENSIONER"			3
Precautions for Working with HFC-134a (R-134a)			3
General Refrigerant Precautions			4
Precautions for Leak Detection Dye			4
Precaution for Identification Label on Vehicle			5
Precautions for Refrigerant Connection			5
Precautions for Servicing Compressor			8
Precautions for Service Equipment			8
Wiring Diagrams and Trouble Diagnosis			10
PREPARATION			11
Special Service Tools			11
HFC-134a (R-134a) Service Tools and Equipment			12
DESCRIPTION			15
Refrigeration System			15
V-6 Variable Displacement Compressor			16
Component Layout			20
Introduction			21
Features			21
Overview of Control System			24
Control Operation			24
Discharge Air Flow			26
System Description			27
TROUBLE DIAGNOSES			28
Component Location			28
Circuit Diagram (Without Navigation System)			30
Wiring Diagram - A/C, A -/Without Navigation System			31
Circuit Diagram (With Navigation System)			34
Wiring Diagram - A/C, A -/With Navigation System			35
Auto Amp. Terminals and Reference Value			39
Self-diagnosis			43
How to Perform Trouble Diagnoses for Quick and Accurate Repair			64
Operational Check			65
A/C System			70
Mode Door Motor			75
Air Mix Door Motor			83
Intake Door Motor			87
Blower Motor			91
Magnet Clutch			101
Insufficient Cooling			108
Insufficient Heating			117
Noise			119
Self-diagnosis			121
Memory Function			122
ECON (ECONOMY) Mode			123
Ambient Sensor Circuit			124
In-vehicle Sensor Circuit			127
Sunload Sensor Circuit			130
Intake Sensor Circuit			134
Air Mix Door Motor PBR Circuit			136
Multiplex Communication Circuit			137
SERVICE PROCEDURE			139
HFC-134a (R-134a) Service Procedure			139
Maintenance of Lubricant Quantity in Compressor			141
Compressor			144
Compressor Clutch			144
Heater Unit (Heater Core)			148
Blower and Cooling Unit (A/C Evaporator)			149
Refrigerant Lines			150
Fluorescent Dye Leak Detector			154
Belt			155
In-cabin Microfilter			155
SERVICE DATA AND SPECIFICATIONS (SDS)			156
Auto			156
<div style="border: 1px solid black; display: inline-block; width: 100px; height: 15px; margin: 0 auto;"></div>	MANUAL	<div style="border: 1px solid black; display: inline-block; width: 100px; height: 15px; margin: 0 auto;"></div>	
PRECAUTIONS			157
Supplemental Restraint System (SRS) "AIR BAG" and "SEAT BELT PRE-TENSIONER"			157

GI
MA
EM
LC
EC
FE
CL
MT
AT
AX
SU
BR
ST
RS
BT
HA
SC
EL
IDX

CONTENTS (Cont'd)

Precautions for Working with HFC-134a (R-134a).....	157	Operational Check.....	186
General Refrigerant Precautions.....	158	A/C System.....	188
Precautions for Leak Detection Dye.....	158	Intake Door.....	191
Precaution for Identification Label on Vehicle.....	159	Blower Motor.....	195
Precautions for Refrigerant Connection.....	159	Air Mix Door.....	201
Precautions for Servicing Compressor.....	162	Mode Door.....	205
Precautions for Service Equipment.....	162	Magnet Clutch.....	208
Wiring Diagrams and Trouble Diagnosis.....	164	Insufficient Cooling.....	215
PREPARATION	165	Insufficient Heating.....	223
Special Service Tools.....	165	Noise.....	224
HFC-134a (R-134a) Service Tools and Equipment.....	166	SERVICE PROCEDURE	225
DESCRIPTION	169	HFC-134a (R-134a) Service Procedure.....	225
Refrigeration System.....	169	Maintenance of Lubricant Quantity in Compressor.....	227
V-6 Variable Displacement Compressor.....	170	Compressor.....	231
Component Layout.....	174	Compressor Clutch.....	231
Control Operation.....	175	Heater Unit (Heater Core).....	235
Discharge Air Flow.....	176	Blower and Cooling Unit (A/C Evaporator).....	236
System Description.....	177	Refrigerant Lines.....	237
TROUBLE DIAGNOSES	178	Fluorescent Dye Leak Detector.....	241
Component Location.....	178	Belt.....	242
Circuit Diagram - Air Conditioner.....	180	In-cabin Microfilter.....	242
Wiring Diagram - A/C, M -.....	181	SERVICE DATA AND SPECIFICATIONS (SDS)	243
How to Perform Trouble Diagnoses for Quick and Accurate Repair.....	185	Manual.....	243

Supplemental Restraint System (SRS) "AIR BAG" and "SEAT BELT PRE-TENSIONER"

NFHA0153

The Supplemental Restraint System such as "AIR BAG" and "SEAT BELT PRE-TENSIONER" used along with a seat belt, helps to reduce the risk or severity of injury to the driver and front passenger for certain types of collision. This system includes seat belt switch inputs and dual stage front air bag modules. The SRS system uses the seat belt switches to determine the front air bag deployment, and may only deploy one front air bag, depending on the severity of a collision and whether the front occupants are belted or unbelted. The SRS system composition which is available to NISSAN MODEL A33 is as follows:

- For a frontal collision
The Supplemental Restraint System consists of driver air bag module (located in the center of the steering wheel), front passenger air bag module (located on the instrument panel on passenger side), seat belt pre-tensioners, a diagnosis sensor unit, crash zone sensor, warning lamp, wiring harness and spiral cable.
- For a side collision
The Supplemental Restraint System consists of front side air bag module (located in the outer side of front seat), satellite sensor, diagnosis sensor unit (one of components of air bags for a frontal collision), wiring harness, warning lamp (one of components of air bags for a frontal collision).

Information necessary to service the system safely is included in the **RS section** of this Service Manual.

WARNING:

- To avoid rendering the SRS inoperative, which could increase the risk of personal injury or death in the event of a collision which would result in air bag inflation, all maintenance should be performed by an authorized NISSAN dealer.
- Improper maintenance, including incorrect removal and installation of the SRS, can lead to personal injury caused by unintentional activation of the system. For removal of Spiral Cable and Air Bag Module, see the RS section.
- Do not use electrical test equipment on any circuit related to the SRS unless instructed to in this Service Manual. SRS wiring harnesses can be identified by yellow and/or orange harness connector.

Precautions for Working with HFC-134a (R-134a)

NFHA0154

WARNING:

- CFC-12 (R-12) refrigerant and HFC-134a (R-134a) refrigerant are not compatible. If the refrigerants are mixed and compressor malfunction is likely to occur, refer to "CONTAMINATED REFRIGERANT" below. To determine the purity of HFC-134a (R-134a) in the vehicle and recovery tank, use Refrigerant Recovery/Recycling Recharging equipment (ACR4) (J-39500-NI) and Refrigerant Identifier.
- Use only specified lubricant for the HFC-134a (R-134a) A/C system and HFC-134a (R-134a) components. If lubricant other than that specified is used, compressor failure is likely to occur.
- The specified HFC-134a (R-134a) lubricant rapidly absorbs moisture from the atmosphere. The following handling precautions must be observed:
 - a) When removing refrigerant components from a vehicle, immediately cap (seal) the component to minimize the entry of moisture from the atmosphere.
 - b) When installing refrigerant components to a vehicle, do not remove the caps (unseal) until just before connecting the components. Connect all refrigerant loop components as quickly as possible to minimize the entry of moisture into system.
 - c) Only use the specified lubricant from a sealed container. Immediately reseal containers of lubricant. Without proper sealing, lubricant will become moisture saturated and should not be used.
 - d) Avoid breathing A/C refrigerant and lubricant vapor or mist. Exposure may irritate eyes, nose and throat. Remove HFC-134a (R-134a) from the A/C system, using certified service equipment meeting requirements of SAE J2210 [HFC-134a (R-134a) recycling equipment], or J2209 [HFC-134a (R-134a) recovery equipment]. If accidental system discharge occurs, ventilate work area before resuming service. Additional health and safety information may be obtained from refrigerant and lubricant manufacturers.
 - e) Do not allow lubricant (Nissan A/C System Oil Type S) to come in contact with styrofoam parts. Damage may result.

CONTAMINATED REFRIGERANT

If a refrigerant other than pure HFC-134a (R-134a) is identified in a vehicle, your options are:

NFHA0154S01

GI
MA
EM
LC
EC
FE
CL
MT
AT
AX
SU
BR
ST
RS
BT
HA
SC
EL
IDX

- Explain to the customer that environmental regulations prohibit the release of contaminated refrigerant into the atmosphere.
- Explain that recovery of the contaminated refrigerant could damage your service equipment and refrigerant supply.
- Suggest the customer return the vehicle to the location of previous service where the contamination may have occurred.
- If you choose to perform the repair, recover the refrigerant using only **dedicated equipment and containers. Do not recover contaminated refrigerant into your existing service equipment.** If your facility does not have dedicated recovery equipment, you may contact a local refrigerant product retailer for available service. This refrigerant must be disposed of in accordance with all federal and local regulations. In addition, replacement of all refrigerant system components on the vehicle is recommended.
- If the vehicle is within the warranty period, the air conditioner warranty is void. Please contact NISSAN Customer Affairs for further assistance.

General Refrigerant Precautions

NFHA0155

WARNING:

- **Do not release refrigerant into the air. Use approved recovery/recycling equipment to capture the refrigerant every time an air conditioning system is discharged.**
- **Always wear eye and hand protection (goggles and gloves) when working with any refrigerant or air conditioning system.**
- **Do not store or heat refrigerant containers above 52°C (125°F).**
- **Do not heat a refrigerant container with an open flame; if container warming is required, place the bottom of the container in a warm pail of water.**
- **Do not intentionally drop, puncture, or incinerate refrigerant containers.**
- **Keep refrigerant away from open flames: poisonous gas will be produced if refrigerant burns.**
- **Refrigerant will displace oxygen, therefore be certain to work in well ventilated areas to prevent suffocation.**
- **Do not pressure test or leak test HFC-134a (R-134a) service equipment and/or vehicle air conditioning systems with compressed air during repair. Some mixtures of air and R-134a have been shown to be combustible at elevated pressures. These mixtures, if ignited, may cause injury or property damage. Additional health and safety information may be obtained from refrigerant manufacturers.**

Precautions for Leak Detection Dye

NFHA0265

- The A/C system contains a fluorescent leak detection dye used for locating refrigerant leaks. An ultraviolet (UV) lamp is required to illuminate the dye when inspecting for leaks.
- Always wear fluorescence enhancing UV goggles to protect your eyes and enhance the visibility of the fluorescent dye.
- A compressor shaft seal should not be repaired because of dye seepage. The compressor shaft seal should only be repaired after confirming the leak with an electronic refrigerant leak detector (J-41995).
- Always remove any dye from the leak area after repairs are complete to avoid a misdiagnosis during a future service.
- Do not allow dye to come into contact with painted body panels or interior components. If dye is spilled, clean immediately with the approved dye cleaner. Fluorescent dye left on a surface for an extended period of time cannot be removed.
- Do not spray the fluorescent dye cleaning agent on hot surfaces (engine exhaust manifold, etc.).
- Do not use more than one refrigerant dye bottle (1/4 ounce /7.4 cc) per A/C system.
- Leak detection dyes for HFC-134a (R-134a) and CFC-12 (R-12) A/C systems are different. Do not use HFC-134a (R-134a) leak detection dye in CFC-12 (R-12) A/C system or CFC-12 (R-12) leak detection dye in HFC-134a (R-134a) A/C systems or A/C system damage may result.
- The fluorescent properties of the dye will remain for over three (3) years unless a compressor malfunction occurs.

AIR CONDITIONER NISSAN		
REFRIGERANT	COMPRESSOR LUBRICANT	
TYPE (PART NO.)	HFC134a (R134a)	Nissan UV Luminous Oil Type S [KLHOO-PAGSO]
AMOUNT		
CAUTION PRECAUTION • REFRIGERANT UNDER HIGH PRESSURE. • SYSTEM TO BE SERVICED BY QUALIFIED PERSONNEL. • IMPROPER SERVICE METHODS MAY CAUSE PERSONAL INJURY. • CONSULT SERVICE MANUAL. • THIS AIR CONDITIONER SYSTEM COMPLIES WITH SAE J-639. Nissan Motor Co., Ltd., TOKYO, Japan 27090 6P102		
SHA436FA		

Precaution for Identification Label on Vehicle

NFHA0266

- Vehicles with factory installed fluorescent dye have this identification label on the under side of hood.
- Vehicles with factory installed fluorescent dye have a green label.
- Vehicles without factory installed fluorescent dye have a blue label.

GI
MA
EM
LC

Precautions for Refrigerant Connection

NFHA0156

A new type refrigerant connection has been introduced to all refrigerant lines except the following location.

- Expansion valve to evaporator

FEATURES OF NEW TYPE REFRIGERANT CONNECTION

- The O-ring has been relocated. It has also been provided with a groove for proper installation. This eliminates the chance of the O-ring being caught in, or damaged by, the mating part. The sealing direction of the O-ring is now set vertically in relation to the contacting surface of the mating part to improve sealing characteristics.
- The reaction force of the O-ring will not occur in the direction that causes the joint to pull out, thereby facilitating piping connections.

EC
FE
CL
MT

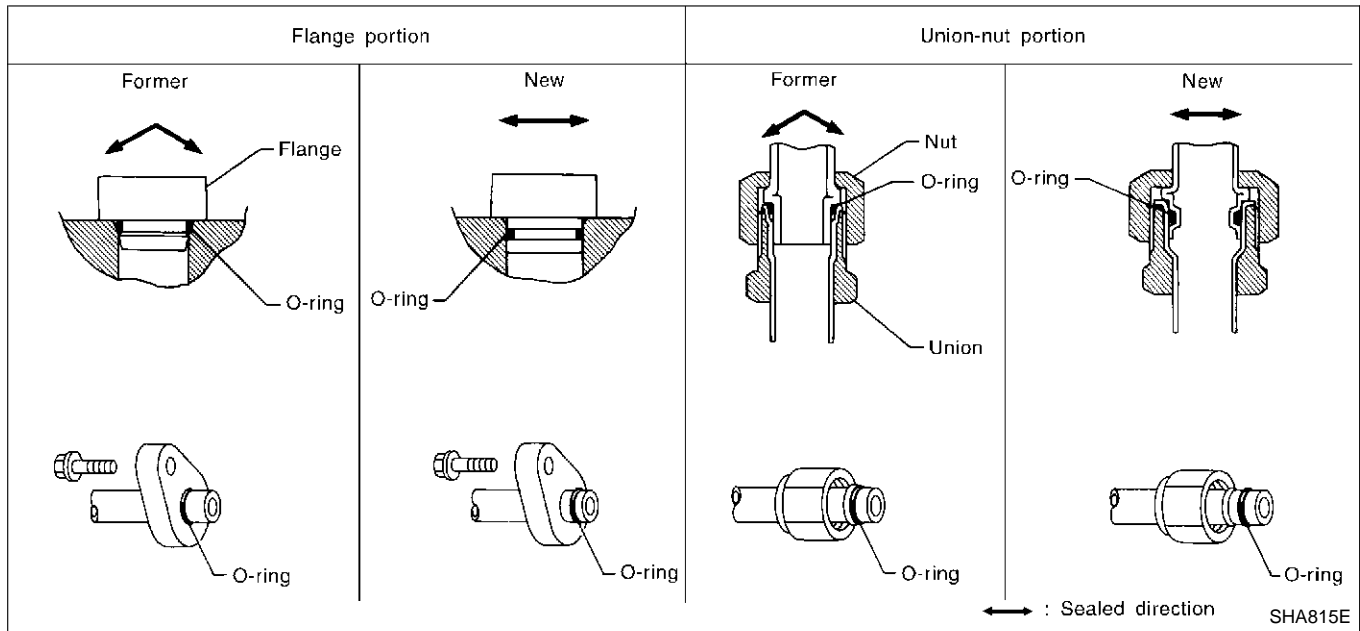

AT
AX
SU
BR
ST
RS
BT

HA

SC

EL

IDX

O-RING AND REFRIGERANT CONNECTION

NFHA0156S02

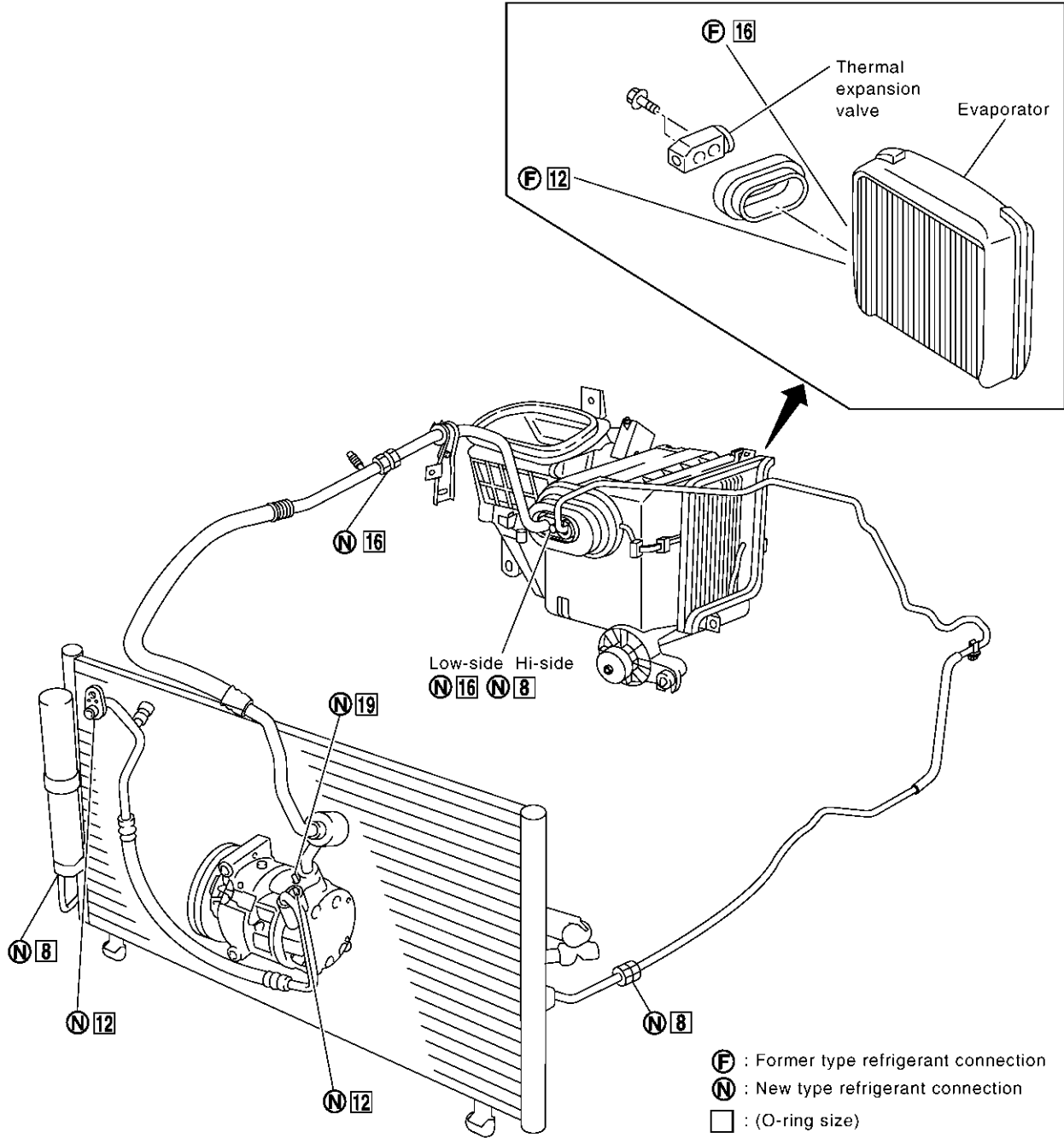

RHA0301

CAUTION:

The new and former refrigerant connections use different O-ring configurations. Do not confuse O-rings since they are not interchangeable. If a wrong O-ring is installed, refrigerant will leak at, or around, the connection.

PRECAUTIONS

AUTO

Precautions for Refrigerant Connection (Cont'd)

O-Ring Part Numbers and Specifications

NFHA0156S0201

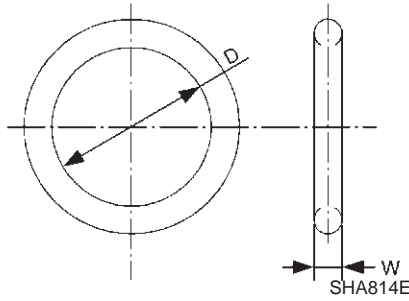

Connection type	O-ring size	Part number	D mm (in)	W mm (in)
New	8	92471 N8210	6.8 (0.268)	1.85 (0.0728)
Former		92470 N8200	6.07 (0.2390)	1.78 (0.0701)
New	12	92472 N8210	10.9 (0.429)	2.43 (0.0957)
Former		92475 71L00	11.0 (0.433)	2.4 (0.094)
New	16	92473 N8210	13.6 (0.535)	2.43 (0.0957)
Former		92475 72L00	14.3 (0.563)	2.3 (0.091)
New	19	92474 N8210	16.5 (0.650)	2.43 (0.0957)
Former		92477 N8200	17.12 (0.6740)	1.78 (0.0701)

WARNING:

Make sure all refrigerant is discharged into the recycling equipment and the pressure in the system is less than atmospheric pressure. Then gradually loosen the discharge side hose fitting and remove it.

CAUTION:

When replacing or cleaning refrigerant cycle components, observe the following.

- When the compressor is removed, store it in the same position as it is when mounted on the car. Failure to do so will cause lubricant to enter the low pressure chamber.
- When connecting tubes, always use a torque wrench and a back-up wrench.
- After disconnecting tubes, immediately plug all openings to prevent entry of dirt and moisture.
- When installing an air conditioner in the vehicle, connect the pipes as the final stage of the operation. Do not remove the seal caps of pipes and other components until just before required for connection.
- Allow components stored in cool areas to warm to working area temperature before removing seal caps. This prevents condensation from forming inside A/C components.
- Thoroughly remove moisture from the refrigeration system before charging the refrigerant.
- Always replace used O-rings.
- When connecting tube, apply lubricant to circle of the O-rings shown in illustration. Be careful not to apply lubricant to threaded portion.
Lubricant name: NISSAN A/C System Oil Type S
Part number: KLH00-PAGS0
- O-ring must be closely attached to dented portion of tube.
- When replacing the O-ring, be careful not to damage O-ring and tube.
- Connect tube until you hear it click, then tighten the nut or bolt by hand until snug. Make sure that the O-ring is installed to tube correctly.
- After connecting line, conduct leak test and make sure that there is no leakage from connections. When the gas leaking point is found, disconnect that line and replace the O-ring. Then tighten connections of seal seat to the specified torque.

Precautions for Refrigerant Connection (Cont'd)

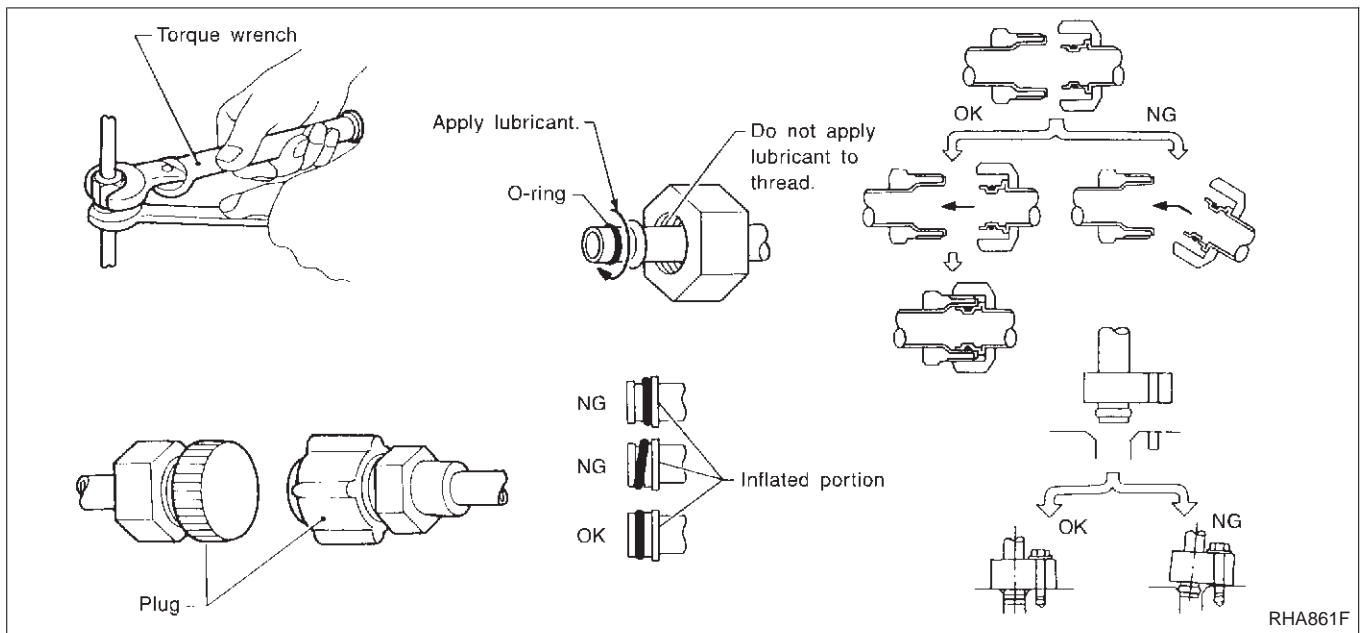

Precautions for Servicing Compressor

NFHA0157

- **Plug all openings to prevent moisture and foreign matter from entering.**
- **When the compressor is removed, store it in the same position as it is when mounted on the car.**
- **When replacing or repairing compressor, follow “Maintenance of Lubricant Quantity in Compressor” exactly. Refer to HA-141.**
- **Keep friction surfaces between clutch and pulley clean. If the surface is contaminated, with lubricant, wipe it off by using a clean waste cloth moistened with thinner.**
- **After compressor service operation, turn the compressor shaft by hand more than five turns in both directions. This will equally distribute lubricant inside the compressor. After the compressor is installed, let the engine idle and operate the compressor for one hour.**
- **After replacing the compressor magnet clutch, apply voltage to the new one and check for normal operation.**

**Precautions for Service Equipment
RECOVERY/RECYCLING EQUIPMENT**

NFHA0158

NFHA0158S01

Be certain to follow the manufacturers instructions for machine operation and machine maintenance. Never introduce any refrigerant other than that specified into the machine.

ELECTRONIC LEAK DETECTOR

NFHA0158S02

Be certain to follow the manufacturer’s instructions for tester operation and tester maintenance.

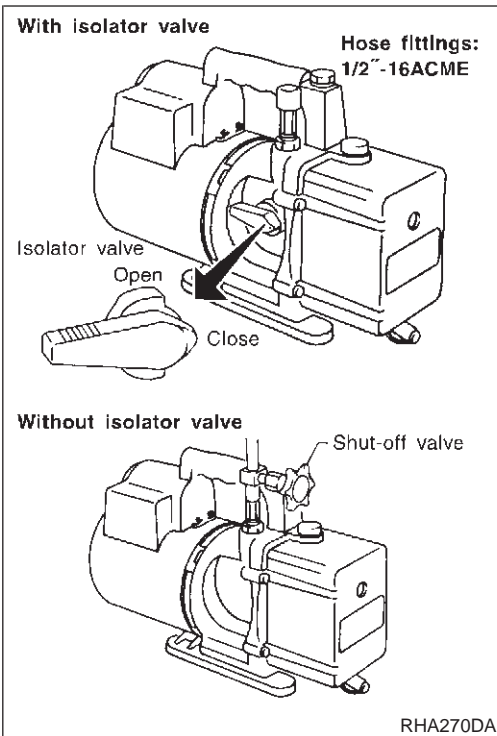

VACUUM PUMP

NFHA0158S03

The lubricant contained inside the vacuum pump is not compatible with the specified lubricant for HFC-134a (R-134a) A/C systems. The vent side of the vacuum pump is exposed to atmospheric pressure. So the vacuum pump lubricant may migrate out of the pump into the service hose. This is possible when the pump is switched off after evacuation (vacuuming) and hose is connected to it.

To prevent this migration, use a manual valve placed near the hose-to-pump connection, as follows.

- Usually vacuum pumps have a manual isolator valve as part of the pump. Close this valve to isolate the service hose from the pump.
- For pumps without an isolator, use a hose equipped with a manual shut-off valve near the pump end. Close the valve to isolate the hose from the pump.
- If the hose has an automatic shut off valve, disconnect the hose from the pump. As long as the hose is connected, the valve is open and lubricating oil may migrate.

Some one-way valves open when vacuum is applied and close under a no vacuum condition. Such valves may restrict the pump's ability to pull a deep vacuum and are not recommended.

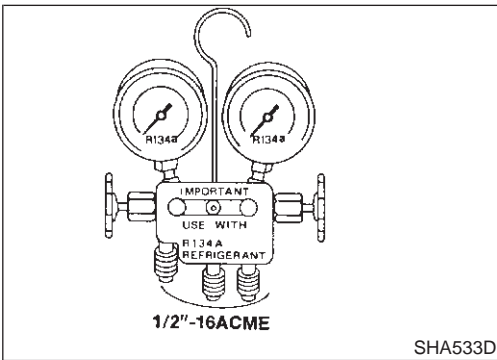

MANIFOLD GAUGE SET

NFHA0158S04

Be certain that the gauge face indicates R-134a. Be sure the gauge set has 1/2"-16 ACME threaded connections for service hoses. Confirm the set has been used only with refrigerant HFC-134a (R-134a) and specified lubricants.

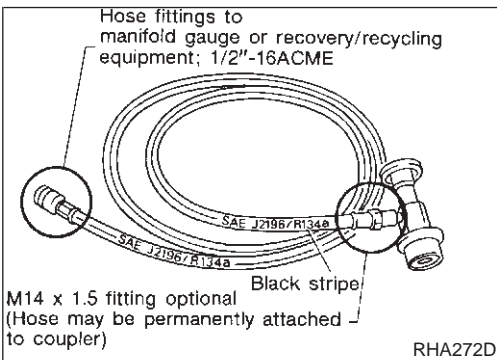

SERVICE HOSES

NFHA0158S05

Be certain that the service hoses display the markings described (colored hose with black stripe). All hoses must include positive shut off devices (either manual or automatic) near the end of the hoses opposite the manifold gauge.

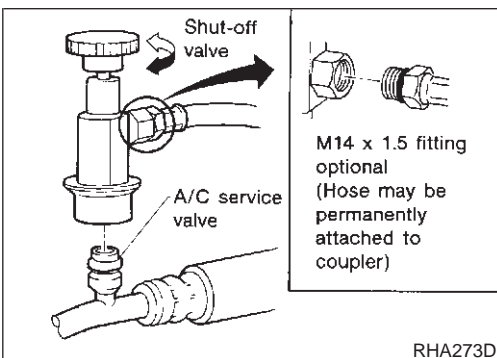

SERVICE COUPLERS

NFHA0158S06

Never attempt to connect HFC-134a (R-134a) service couplers to an CFC-12 (R-12) A/C system. The HFC-134a (R-134a) couplers will not properly connect to the CFC-12 (R-12) system. However, if an improper connection is attempted, discharging and contamination may occur.

Shut-off valve rotation	A/C service valve
Clockwise	Open
Counterclockwise	Close

GI
MA
EM
LC
EC
FE
CL
MT
AT
AX
SU
BR
ST
RS
BT
HA
SC
EL
IDX

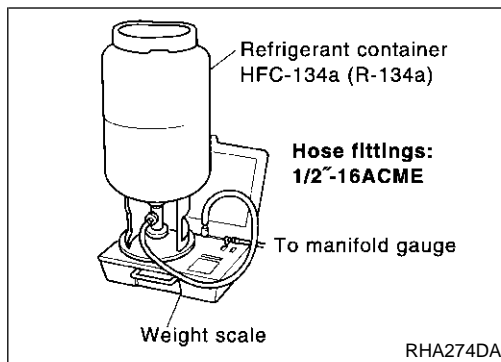

REFRIGERANT WEIGHT SCALE

NFHA0158S07

Verify that no refrigerant other than HFC-134a (R-134a) and specified lubricants have been used with the scale. If the scale controls refrigerant flow electronically, the hose fitting must be 1/2"-16 ACME.

CALIBRATING ACR4 WEIGHT SCALE

NFHA0158S08

Calibrate the scale every three months.

To calibrate the weight scale on the ACR4 (J-39500-NI):

1. Press **Shift/Reset** and **Enter** at the same time.
2. Press **8787**. "A1" will be displayed.
3. Remove all weight from the scale.
4. Press **0**, then press **Enter**. "0.00" will be displayed and change to "A2".
5. Place a known weight (dumbbell or similar weight), between 4.5 and 8.6 kg (10 and 19 lb) on the center of the weight scale.
6. Enter the known weight using four digits. (Example 10 lb = 10.00, 10.5 lb = 10.50)
7. Press **Enter** — the display returns to the vacuum mode.
8. Press **Shift/Reset** and **Enter** at the same time.
9. Press **6** — the known weight on the scale is displayed.
10. Remove the known weight from the scale. "0.00" will be displayed.
11. Press **Shift/Reset** to return the ACR4 to the program mode.

CHARGING CYLINDER

NFHA0158S09

Using a charging cylinder is not recommended. Refrigerant may be vented into air from cylinder's top valve when filling the cylinder with refrigerant. Also, the accuracy of the cylinder is generally less than that of an electronic scale or of quality recycle/recharge equipment.

Wiring Diagrams and Trouble Diagnosis

NFHA0159

When you read wiring diagrams, refer to the following:

- GI-11, "HOW TO READ WIRING DIAGRAMS" in GI section
- EL-12, "Wiring Diagram — POWER —" for power distribution circuit in EL section

When you perform trouble diagnosis, refer to the following:

- GI-35, "HOW TO FOLLOW TEST GROUPS IN TROUBLE DIAGNOSES" in GI section
- GI-24, "HOW TO PERFORM EFFICIENT DIAGNOSIS FOR AN ELECTRICAL INCIDENT" in GI section

Special Service Tools

NFHA0160

The actual shapes of Kent-Moore tools may differ from those of special service tools illustrated here.

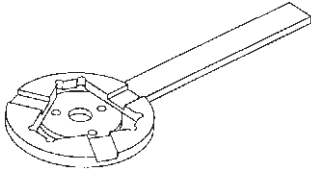
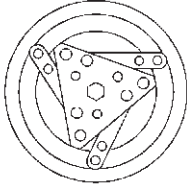
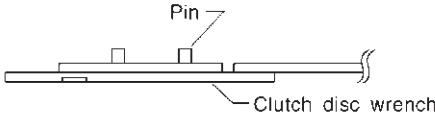
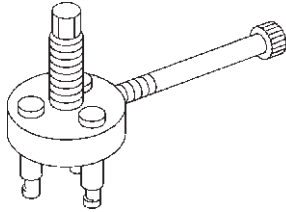
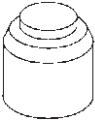
Tool number (Kent-Moore No.) Tool name	Description	
KV99106100 (J-41260) Clutch disc wrench	<p>NT232</p>  <p>Removing center bolt</p>  <p>When replacing the magnet clutch in the above compressor, use a clutch disc wrench with the pin side on the clutch disc to remove it.</p>  <p>NT378</p>	GI MA EM LC EC FE CL MT AT AX
KV99232340 (J-38874) or KV992T0001 (—) Clutch disc puller	<p>NT376</p>  <p>Removing clutch disc</p>	SU BR ST
KV99106200 (J-41261) Pulley installer	<p>NT235</p>  <p>Installing pulley</p>	RS BT

HA

SC

EL

IDX

PREPARATION

AUTO

HFC-134a (R-134a) Service Tools and Equipment

HFC-134a (R-134a) Service Tools and Equipment



=NFHA0161

Never mix HFC-134a (R-134a) refrigerant and/or its specified lubricant with CFC-12 (R-12) refrigerant and/or its lubricant.

Separate and non-interchangeable service equipment must be used for handling each type of refrigerant/lubricant.

Refrigerant container fittings, service hose fittings and service equipment fittings (equipment which handles refrigerant and/or lubricant) are different between CFC-12 (R-12) and HFC-134a (R-134a). This is to avoid mixed use of the refrigerants/lubricant.

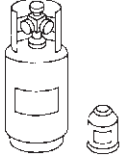

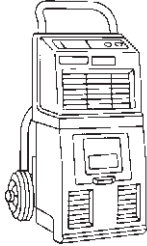
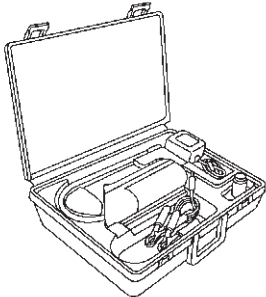

Adapters that convert one size fitting to another must never be used: refrigerant/lubricant contamination will occur and compressor malfunction will result.

Tool number (Kent-Moore No.) Tool name	Description	
HFC-134a (R-134a) refrigerant		Container color: Light blue Container marking: HFC-134a (R-134a) Fitting size: Thread size ● Large container 1/2"-16 ACME
	NT196	
KLH00-PAGS0 (—) Nissan A/C System Oil Type S		Type: Poly alkylene glycol oil (PAG), type S Application: HFC-134a (R-134a) swash plate (piston) compressors (Nissan only) Lubricity: 40 ml (1.4 US fl oz, 1.4 Imp fl oz)
	NT197	
(J-39500-NI) Recovery/Recycling Recharging equipment (ACR4)		Function: Refrigerant Recovery and Recycling and Recharging
	NT195	
(J-41995) Electrical leak detector		Power supply: ● DC 12V (Cigarette lighter)
	AHA281A	

PREPARATION

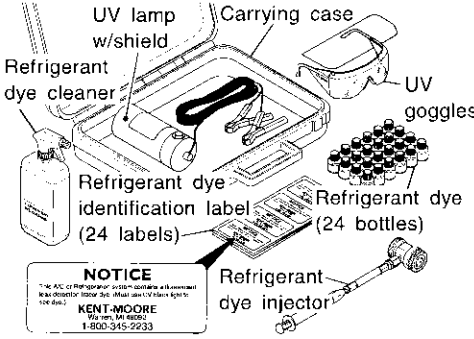
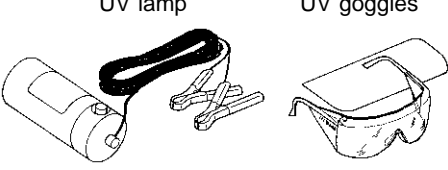
AUTO

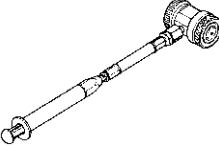

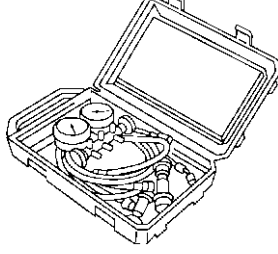
HFC-134a (R-134a) Service Tools and Equipment (Cont'd)

Tool number (Kent-Moore No.) Tool name	Description		
(J-43926) Refrigerant dye leak detection kit Kit includes: (J-42220) UV lamp and UV goggles (J-41459) Refrigerant dye injector (J-41447) qty. 24 HFC-134a (R-134a) refrigerant dye (J-43872) Refrigerant dye cleaner	 <p>UV lamp w/shield Carrying case Refrigerant dye cleaner UV goggles Refrigerant dye identification label (24 labels) Refrigerant dye (24 bottles) Refrigerant dye injector</p> <p>NOTICE The A/C or Refrigerant system contains a flammable mixture of gases. Do not use UV lamp light to illuminate the system. KENT-MOORE For more information call 1-800-345-2233</p>	Power supply: DC 12V (Battery terminal)	GI MA EM LC EC
(J-42220) Fluorescent dye leak detector	 <p>UV lamp UV goggles</p>	Power supply: DC12V (Battery terminal) For checking refrigerant leak when fluorescent dye is installed in A/C system. Includes: UV lamp and UV goggles	FE CL MT
(J-41447) HFC-134a (R-134a) Fluorescent Leak Detection Dye (Box of 24, 1/4 ounce bottles)	 <p>Dye Refrigerant dye (24 bottles)</p>	Application: For HFC-134a (R-134a) PAG oil Container: 1/4 ounce (7.4 cc) bottle (Includes self-adhesive dye identification labels for affixing to vehicle after charging system with dye.)	AT AX SU
(J-41459) HFC-134a (R-134a) Dye Injector Use with J-41447, 1/4 ounce bottle	 <p>Dye injector</p>	For injecting 1/4 ounce of Fluorescent Leak Detec- tion Dye into A/C system.	BR ST RS
(J-43872) Dye cleaner		For cleaning dye spills.	BT HA
(J-39183) Manifold gauge set (with hoses and cou- plers)		Identification: ● The gauge face indicates HFC-134a (R-134a). Fitting size: Thread size ● 1/2"-16 ACME	SC EL IDX

PREPARATION

AUTO

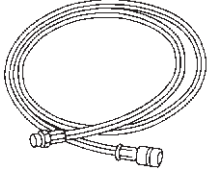
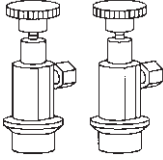
HFC-134a (R-134a) Service Tools and Equipment (Cont'd)

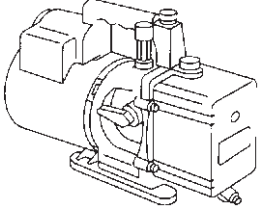
Tool number (Kent-Moore No.) Tool name	Description	
Service hoses <ul style="list-style-type: none"> ● High side hose (J-39501-72) ● Low side hose (J-39502-72) ● Utility hose (J-39476-72) 		Hose color: <ul style="list-style-type: none"> ● Low hose: Blue with black stripe ● High hose: Red with black stripe ● Utility hose: Yellow with black stripe or green with black stripe Hose fitting to gauge: <ul style="list-style-type: none"> ● 1/2"-16 ACME
Service couplers <ul style="list-style-type: none"> ● High side coupler (J-39500-20) ● Low side coupler (J-39500-24) 		Hose fitting to service hose: <ul style="list-style-type: none"> ● M14 x 1.5 fitting is optional or permanently attached.
(J-39650) Refrigerant weight scale		For measuring of refrigerant Fitting size: Thread size <ul style="list-style-type: none"> ● 1/2"-16 ACME
(J-39649) Vacuum pump (Including the isolator valve)		Capacity: <ul style="list-style-type: none"> ● Air displacement: 4 CFM ● Micron rating: 20 microns ● Oil capacity: 482 g (17 oz) Fitting size: Thread size <ul style="list-style-type: none"> ● 1/2"-16 ACME

COMMERCIAL SERVICE TOOL

NFHA0161S01

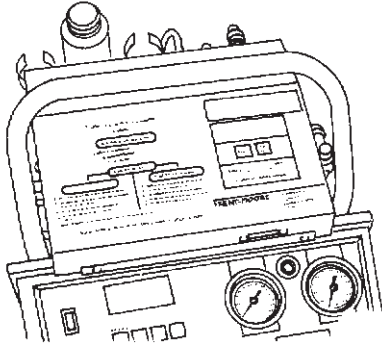
Tool name	Description	
Refrigerant identifier equipment		For checking refrigerant purity and for system contamination

Refrigeration System

REFRIGERATION CYCLE

NFHA0162

Refrigerant Flow

The refrigerant flows in the standard pattern, that is, through the compressor, the condenser, the liquid tank, through the evaporator, and back to the compressor. The refrigerant evaporation through the evaporator coil is controlled by an externally equalized expansion valve, located inside the evaporator case.

NFHA0162S01

Freeze Protection

Under normal operating conditions, when the A/C is switched on, the compressor runs continuously, and the evaporator pressure, and therefore, temperature is controlled by the V-6 variable displacement compressor to prevent freeze up.

NFHA0162S02

Refrigerant System Protection

Refrigerant Pressure Sensor

The refrigerant system is protected against excessively high or low pressures by the refrigerant pressure sensor, located on the condenser. If the system pressure rises above, or falls below the specifications, the refrigerant pressure sensor detects the pressure inside the refrigerant line and sends the voltage signal to the ECM. ECM makes the A/C relay go OFF and stops the compressor when pressure on the high pressure side detected by refrigerant pressure sensor is over about 2,746 kPa (28 kg/cm², 398 psi), psi or below about 177 kPa (1.8 kg/cm², 26 psi).

NFHA0162S03

NFHA0162S0301

Pressure Relief Valve

The refrigerant system is also protected by a pressure relief valve, located in the rear head of the compressor. When the pressure of refrigerant in the system increases to an unusual level [more than 3,727 kPa (38 kg/cm², 540 psi)], the release port on the pressure relief valve automatically opens and releases refrigerant into the atmosphere.

NFHA0162S0302

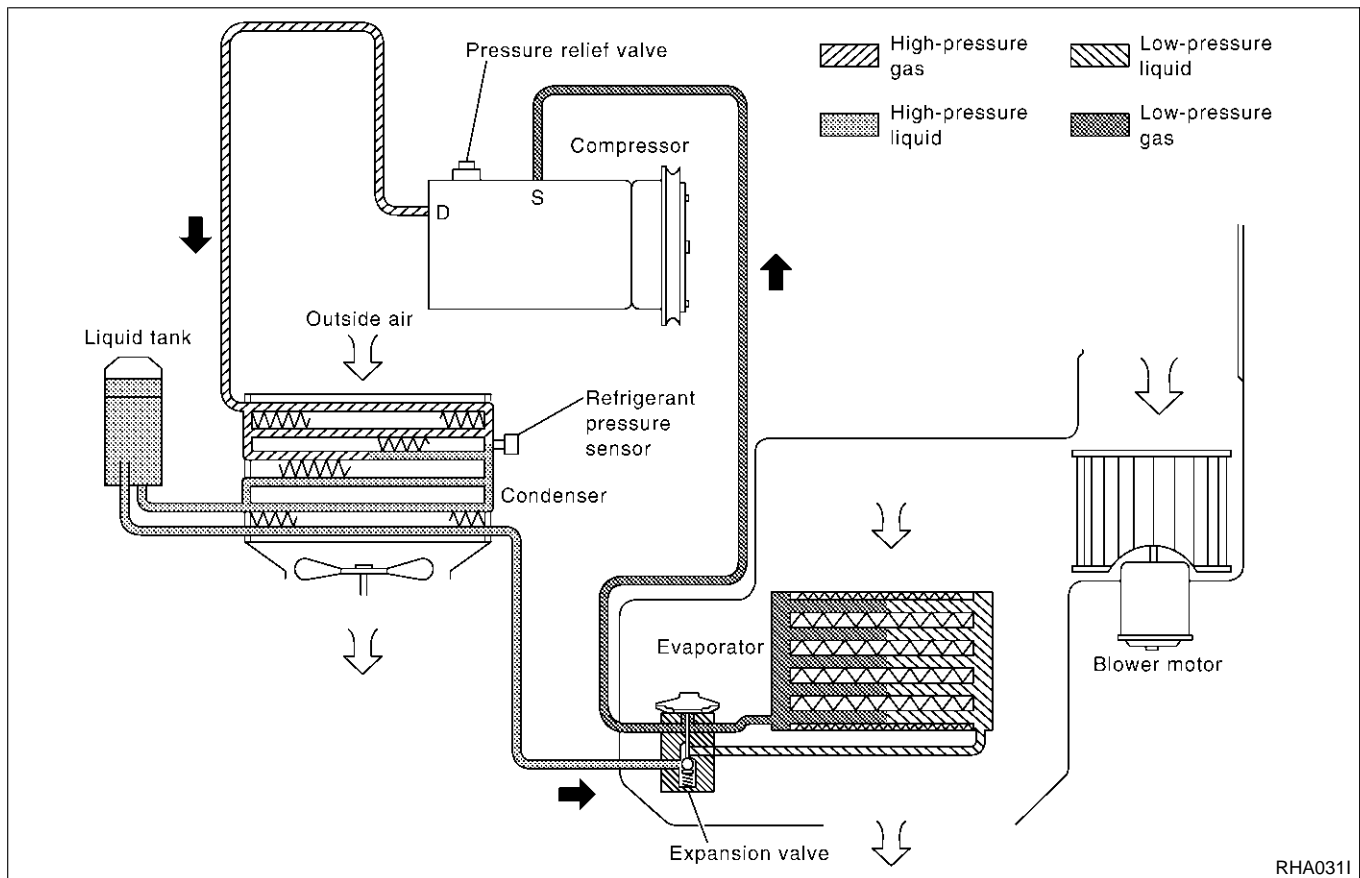

RHA0311

GI
MA
EM
LC
EC
FE
CL
MT
AT
AX
SU
BR
ST
RS
BT
HA
SC
EL
IDX

V-6 Variable Displacement Compressor

GENERAL INFORMATION

1. The V-6 variable compressor differs from previous units. The vent temperatures of the V-6 variable compressor do not drop too far below 5°C (41°F) when:
 - evaporator intake air temperature is less than 20°C (68°F)
 - engine is running at speeds less than 1,500 rpm.This is because the V-6 compressor provides a means of “capacity” control.
2. The V-6 variable compressor provides refrigerant control under varying conditions. During cold winters, it may not produce high refrigerant pressure discharge (compared to previous units) when used with air conditioning systems.
3. A “clanking” sound may occasionally be heard during refrigerant charge. The sound indicates that the tilt angle of the swash plate has changed and is not a problem.
4. For air conditioning systems with the V-6 compressor, the clutch remains engaged unless: the system main switch, fan switch or ignition switch is turned OFF. When ambient (outside) temperatures are low or when the amount of refrigerant is insufficient, the clutch is disengaged to protect the compressor.
5. A constant range of suction pressure is maintained when engine speed is greater than a certain value. It normally ranges from 147 to 177 kPa (1.5 to 1.8 kg/cm², 21 to 26 psi) under varying conditions. In previous compressors, however, suction pressure was reduced with increases in engine speed.

=NFHA0163

DESCRIPTION

General

The variable compressor is basically a swash plate type that changes piston stroke in response to the required cooling capacity.

The tilt of the swash plate allows the piston's stroke to change so that refrigerant discharge can be continuously changed from 14.5 to 184 cm³ (0.885 to 11.228 cu in).

=NFHA0164

NFHA0164S01

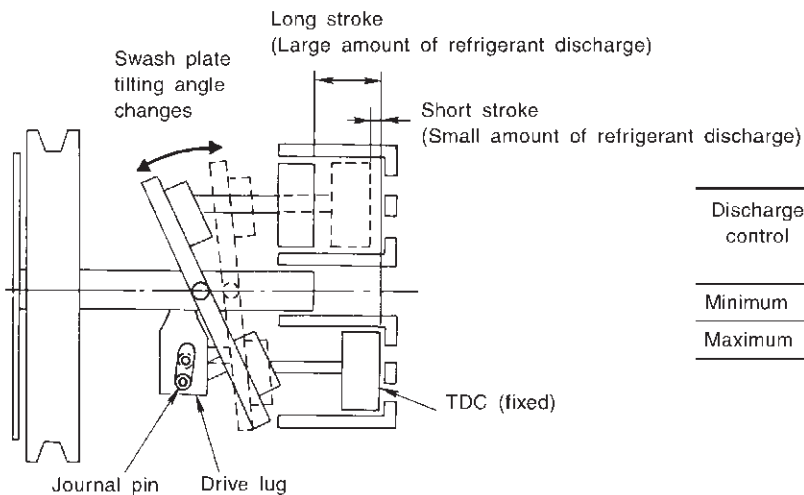
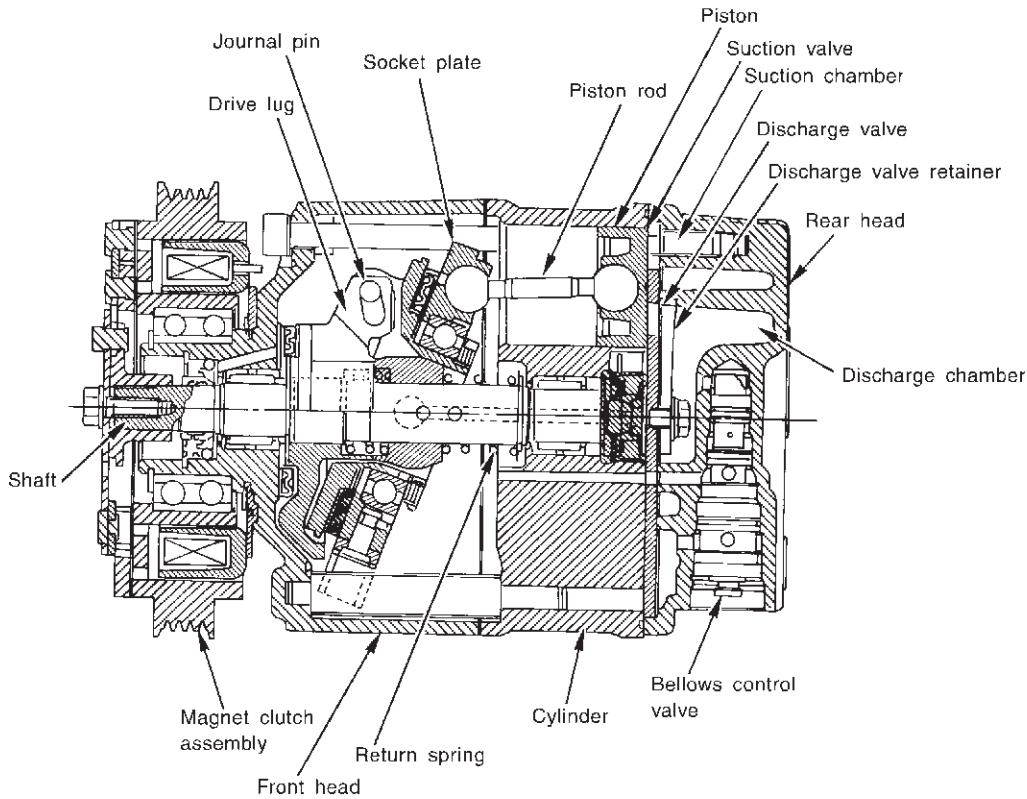

Discharge control	Discharge capacity cm ³ (cu in)/rev.	Piston stroke length mm (in)
Minimum	14.5 (0.885)	2.3 (0.091)
Maximum	184 (11.228)	28.6 (1.126)

RHA037DD

GI
MA
EM
LC
EC
FE
CL
MT
AT
AX
SU
BR
ST
RS
BT
HA
SC
EL
IDX

Operation

=NFHA0164S02

1. Operation Control Valve

NFHA0164S0201

Operation control valve is located in the suction port (low-pressure) side, and opens or closes in response to changes in refrigerant suction pressure.

Operation of the valve controls the internal pressure of the crankcase.

The angle of the swash plate is controlled between the crankcase's internal pressure and the piston cylinder pressure.

2. Maximum Cooling

NFHA0164S0202

Refrigerant pressure on the low-pressure side increases with an increase in heat loads.

When this occurs, the control valve's bellows compress to open the low-pressure side valve and close the high-pressure side valve.

This causes the following pressure changes:

- the crankcase's internal pressure to equal the pressure on the low-pressure side;
- the cylinder's internal pressure to be greater than the crankcase's internal pressure.

Under this condition, the swash plate is set to the maximum stroke position.

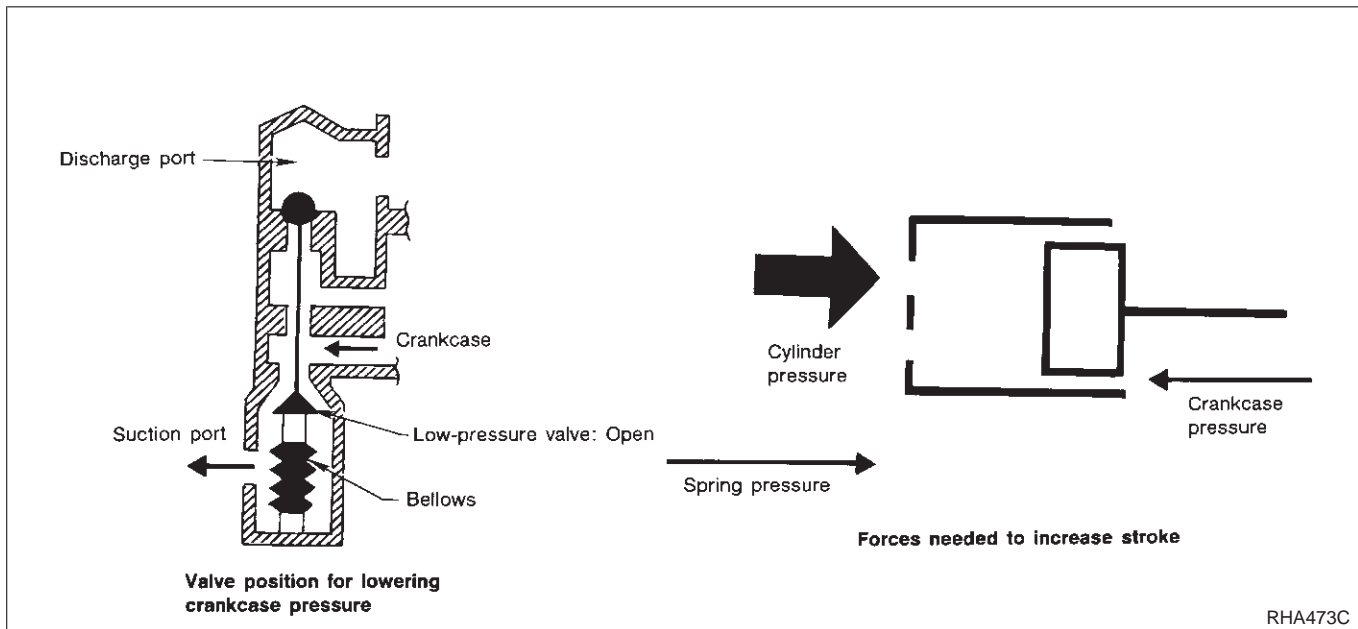

=NFHA0164S0203

3. Capacity Control

- Refrigerant pressure on suction side is low during high speed driving or when ambient or interior temperature is low.
- The bellows expands when refrigerant pressure on the suction pressure side drops below approximately 177 kPa (1.8 kg/cm², 26 psi).
Since suction pressure is low, it makes the suction port close and the discharge port open. Thus, crankcase pressure becomes high as high pressure enters the crankcase.
- The force acts around the journal pin near the swash plate, and is generated by the pressure difference before and behind the piston.
The drive lug and journal pin are located where the piston generates the highest pressure. Piston pressure is between suction pressure P_s and discharge pressure P_d , which is near suction pressure P_s . If crankcase pressure P_c rises due to capacity control, the force around the journal pin makes the swash plate angle decrease and also the piston stroke decrease. In other words, crankcase pressure increase triggers pressure difference between the piston and the crankcase. The pressure difference changes the angle of the swash plate.

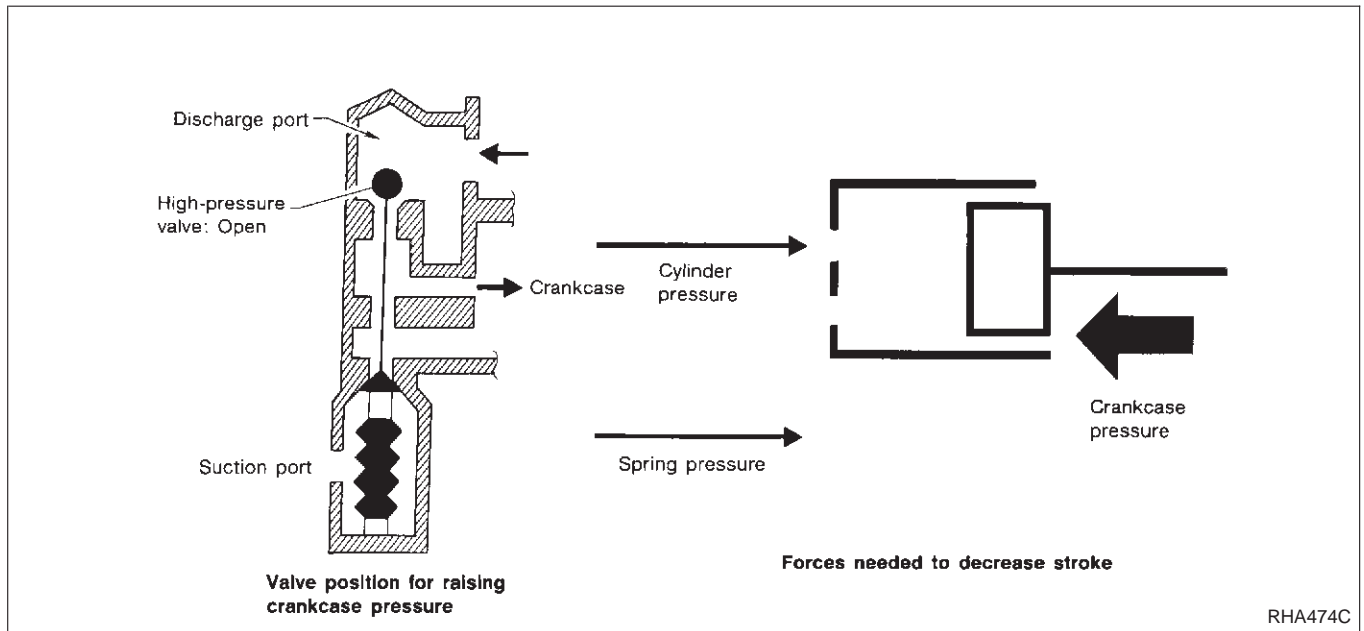

GI
MA
EM
LC
EC
FE
CL
MT
AT
AX
SU
BR
ST
RS
BT
HA
SC
EL
IDX

Component Layout

NFHA0166

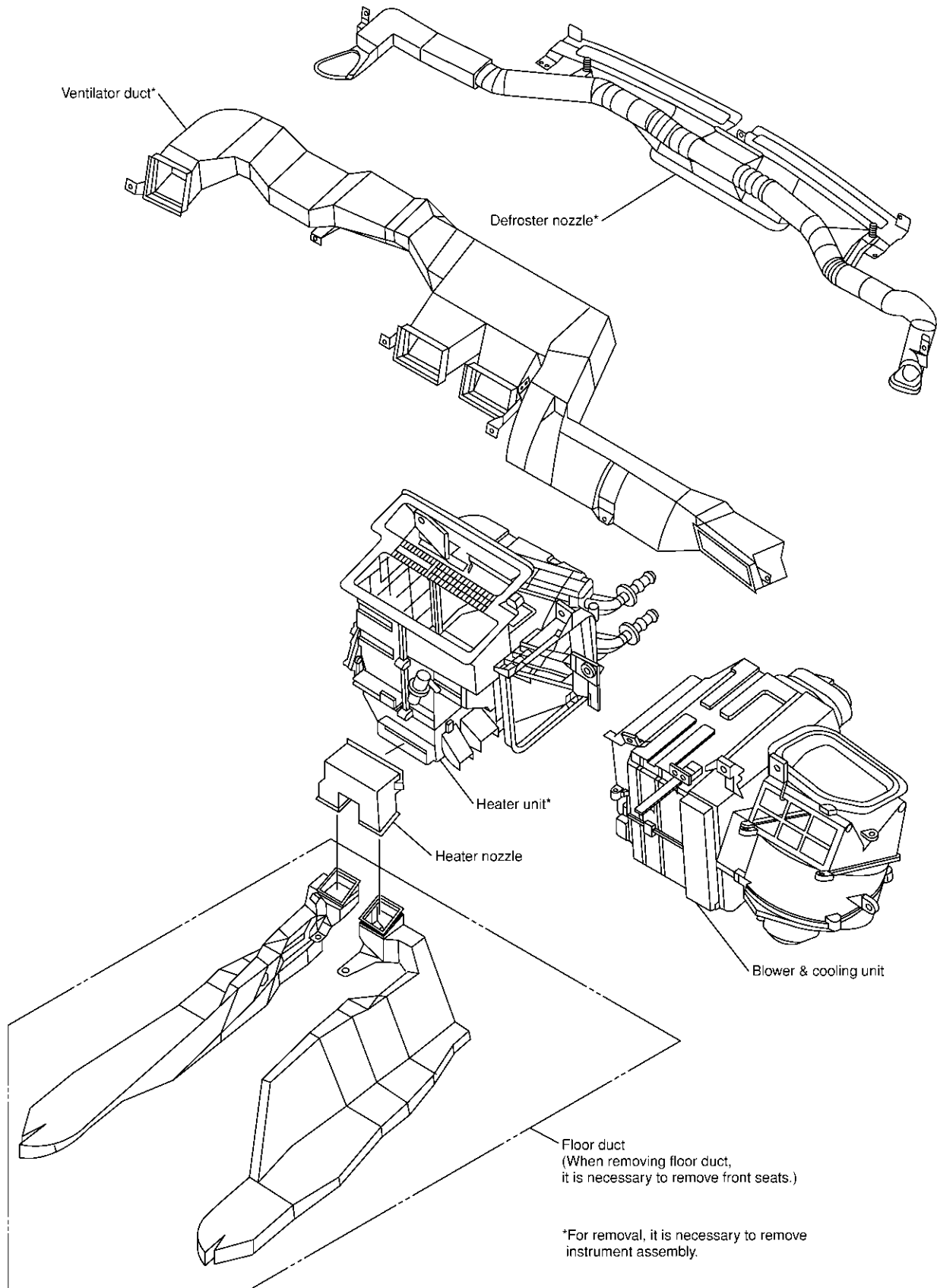

RHA349H

Introduction

AIR CONDITIONER LAN SYSTEM OVERVIEW CONTROL SYSTEM

NFHA0167

NFHA0167S01

The LAN system consists of auto amp., air mix door motor, intake door motor and mode door motor. A configuration of these components is shown in the diagram below.

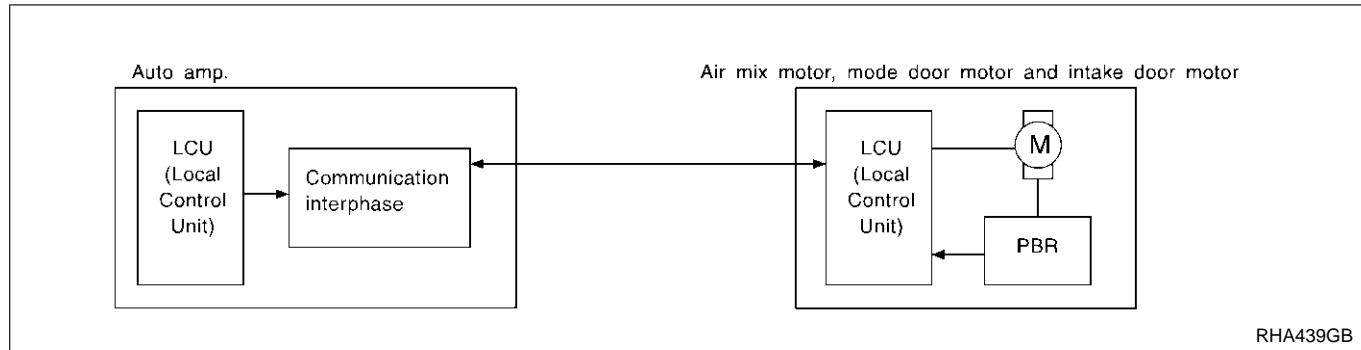

Features

NFHA0168

SYSTEM CONSTRUCTION (LAN)

NFHA0168S01

A small network is constructed between the auto amplifier, air mix door motor, mode door motor and intake door motor. The auto amplifier and motors are connected by data transmission lines and motor power supply lines. The LAN network is built through the ground circuits of the three motors.

Addresses, motor opening angle signals, motor stop signals and error checking messages are all transmitted through the data transmission lines connecting the auto amplifier and three motors.

The following functions are contained in LCUs built into the air mix door motor, intake door motor and the mode door motor.

- Address
- Motor opening angle signals
- Data transmission
- Motor stop and drive decision
- Opening angle sensor (PBR function)
- Comparison
- Decision (Auto amplifier indicated value and motor opening angle comparison)

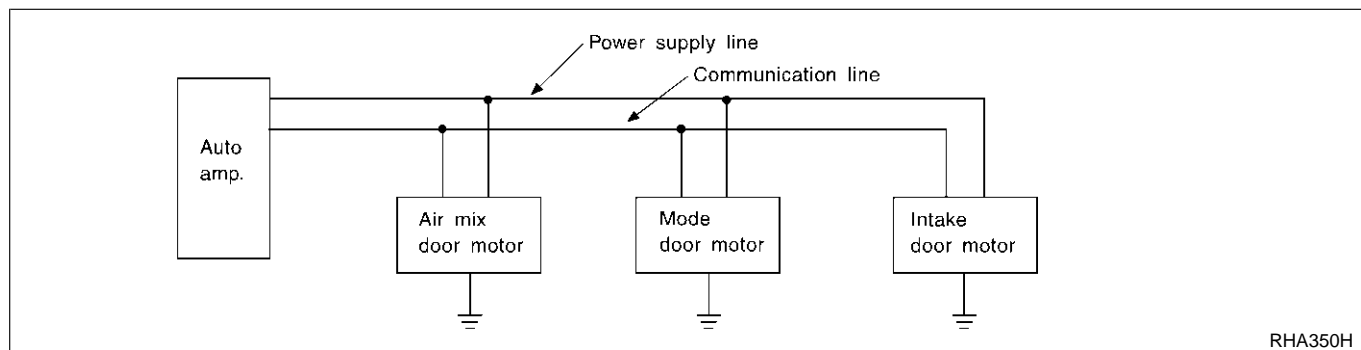

Operation

NFHA0168S0101

The auto amplifier receives data from each of the sensors. The amplifier sends air mix door, intake door and mode door opening angle data to the air mix door motor LCU, mode door motor LCU and intake door motor LCU.

The air mix door motor, intake door motor and mode door motor read their respective signals according to the address signal. Opening angle indication signals received from the auto amplifier and each of the motor position sensors are compared by the LCUs in each motor with the existing decision and opening angles. Subsequently, HOT/COLD, FRESH/RECIRCULATION or DEFROST/VENT operation is selected. The new selection data is returned to the auto amplifier.

Features (Cont'd)

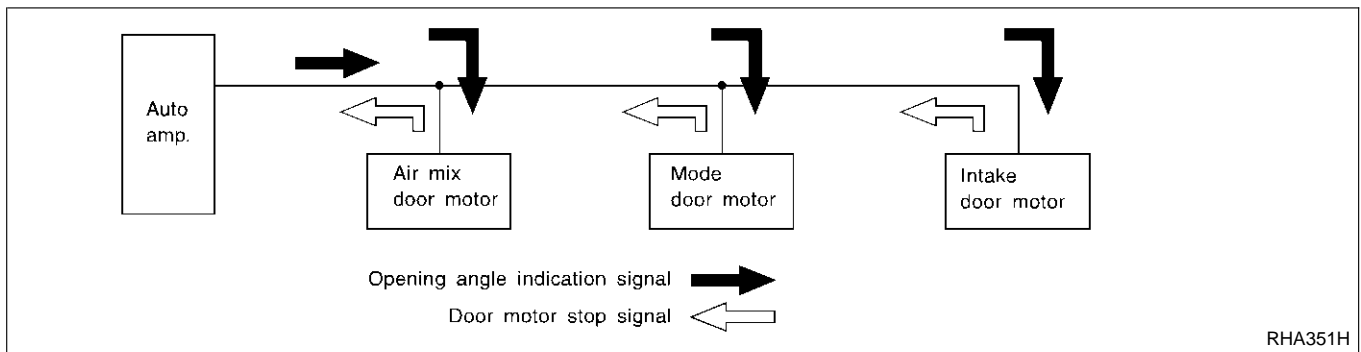

RHA351H

Transmission Data and Transmission Order

NFHA0168S0102

Amplifier data is transmitted consecutively to each of the door motors following the form shown in figure below. Start: Initial compulsory signal sent to each of the door motors.

Address: Data sent from the auto amplifier is selected according to data-based decisions made by the air mix door motor, intake door motor and mode door motor.

If the addresses are identical, the opening angle data and error check signals are received by the door motor LCUs. The LCUs then make the appropriate error decision. If the opening angle data is normal, door control begins.

If an error exists, the received data is rejected and corrected data received. Finally, door control is based upon the corrected opening angle data.

Opening angle: Data that shows the indicated door opening angle of each door motor.

Error check: Procedure by which sent and received data is checked for errors. Error data is then compiled. The error check prevents corrupted data from being used by the air mix door motor, intake door motor and mode door motor. Error data can be related to the following problems.

- Inaccurate electrical frequency
- Poor electrical connections
- Signal leakage from transmission lines
- Signal level fluctuation

Stop signal: At the end of each transmission, a stop operation, in-operation, or internal problem message is delivered to the auto amplifier. This completes one data transmission and control cycle.

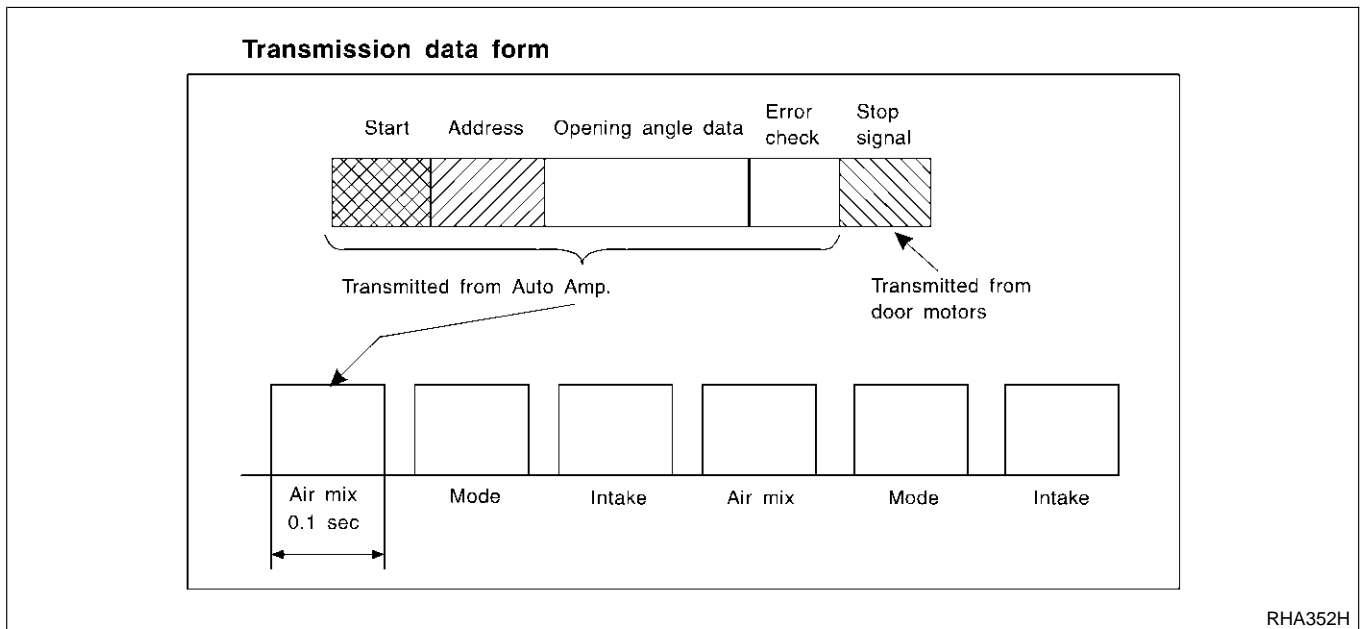

RHA352H

Air Mix Door Control (Automatic Temperature Control)

NFHA0168S0103

The air mix door is automatically controlled so that in-vehicle temperature is maintained at a predetermined value by: The temperature setting, ambient temperature, in-vehicle temperature and amount of sunload.

Fan Speed Control

NFHA0168S0104

Blower speed is automatically controlled based on temperature setting, ambient temperature, in-vehicle temperature, intake temperature, amount of sunload and air mix door position.

With FAN switch set to "AUTO", the blower motor starts to gradually increase air flow volume.

When engine coolant temperature is low, the blower motor operation is delayed to prevent cool air from flowing.

GI

MA

Intake Door Control

NFHA0168S0105

The intake doors are automatically controlled based on temperature setting, ambient temperature, in-vehicle temperature, intake temperature, amount of sunload, air mix door position and ON-OFF operation of the compressor.

EM

LC

Outlet Door Control

NFHA0168S0106

The outlet door is automatically controlled by: The temperature setting, ambient temperature, in-vehicle temperature, intake temperature and amount of sunload.

EC

Magnet Clutch Control

NFHA0168S0107

The ECM controls compressor operation using input signals from the throttle position sensor, refrigerant pressure sensor and auto amplifier.

FE

Self-diagnostic System

NFHA0168S0108

The self-diagnostic system is built into the auto amplifier (LCU) to quickly locate the cause of problems.

CL

MT

AT

AX

SU

BR

ST

RS

BT

HA

SC

EL

IDX

Overview of Control System

=NFHA0169

The control system consists of input sensors, switches, the automatic amplifier (microcomputer) and outputs. The relationship of these components is shown in the diagram below:

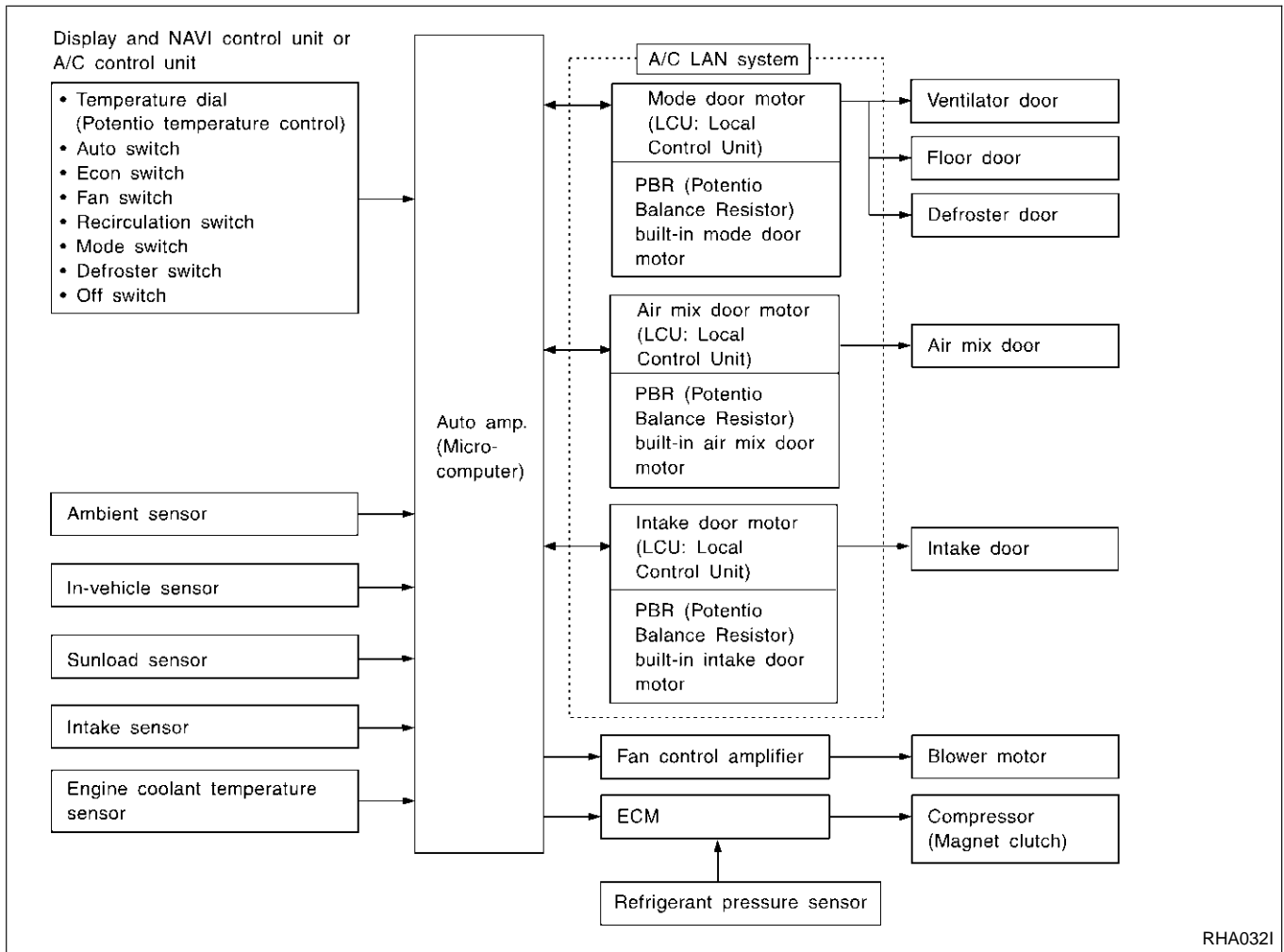

Control Operation

NFHA0170

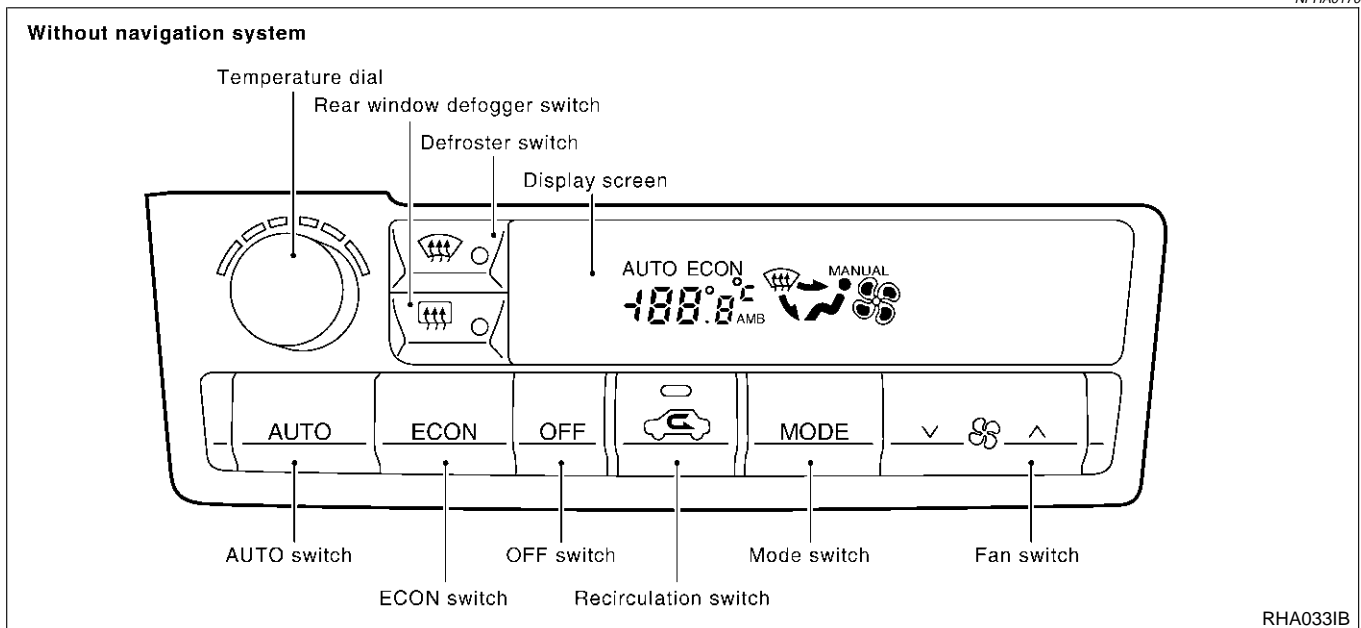

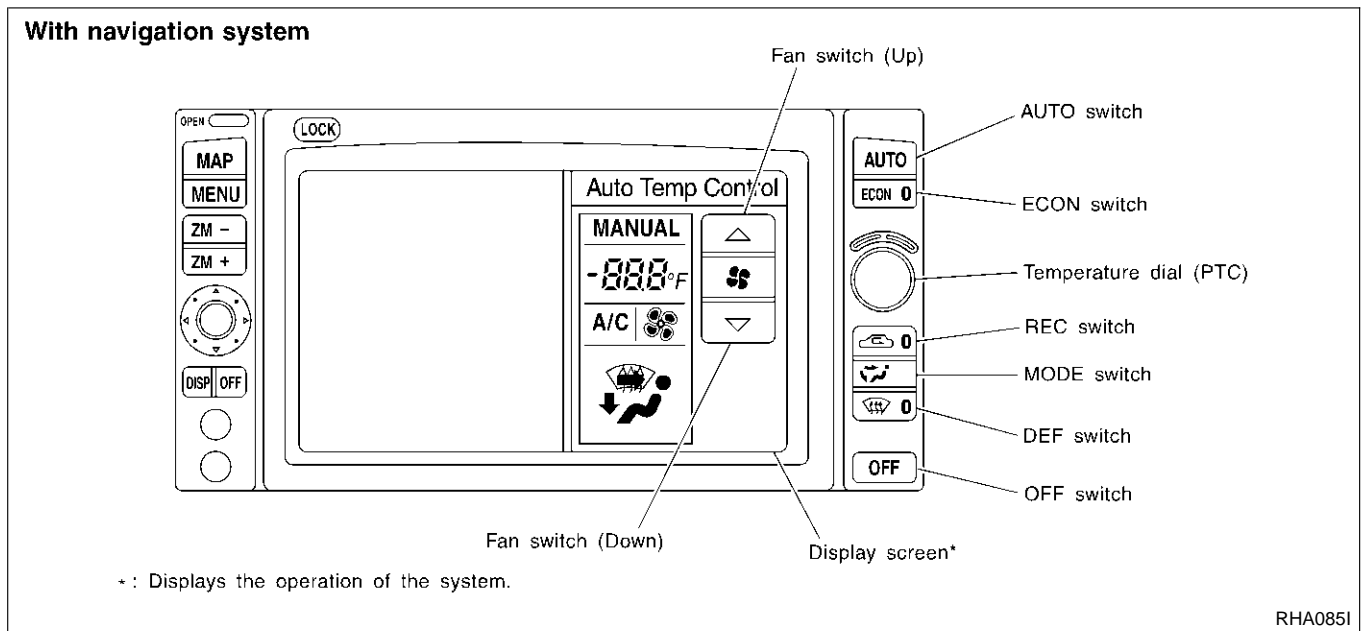

DISPLAY SCREEN

Displays the operational status of the system.

NFHA0170S01

AUTO SWITCH

The compressor, intake doors, air mix door, outlet doors, and blower speed are automatically controlled so that the in-vehicle temperature will reach, and be maintained at the set temperature selected by the operator.

NFHA0170S02

ECON SWITCH

By pressing the ECON switch, the display should indicate ECON and the compressor always turns OFF. With the compressor OFF, the system will not remove heat (cool) or de-humidify. The system will maintain the in-vehicle temperature at the set temperature when the set temperature is above the ambient (outside) temperature. The system will set the intake doors to the outside air position.

NFHA0170S03

TEMPERATURE DIAL (POTENTIO TEMPERATURE CONTROL)

Increases or decreases the set temperature.

NFHA0170S04

OFF SWITCH





The compressor and blower are OFF, the intake doors are set to the outside air position, and the air outlet doors are set to the foot (80% foot and 20% defrost) position.

NFHA0170S05

FAN SWITCH

Manual control of the blower speed. Four speeds are available for manual control (as shown on the display screen):

NFHA0170S06

low , medium low , medium high , high 

RECIRCULATION (REC) SWITCH

OFF position: Outside air is drawn into the passenger compartment.

ON position: Interior air is recirculated inside the vehicle.

NFHA0170S07

DEFROSTER (DEF) SWITCH

Positions the air outlet doors to the defrost position. Also positions the intake doors to the outside air position.

NFHA0170S08

MODE SWITCH

Control the air discharge outlets.

NFHA0170S09

REAR WINDOW DEFOGGER SWITCH (WITHOUT NAVIGATION SYSTEM)

When illumination is ON, rear window is defogged.

NFHA0170S10

Discharge Air Flow

NFHA0171

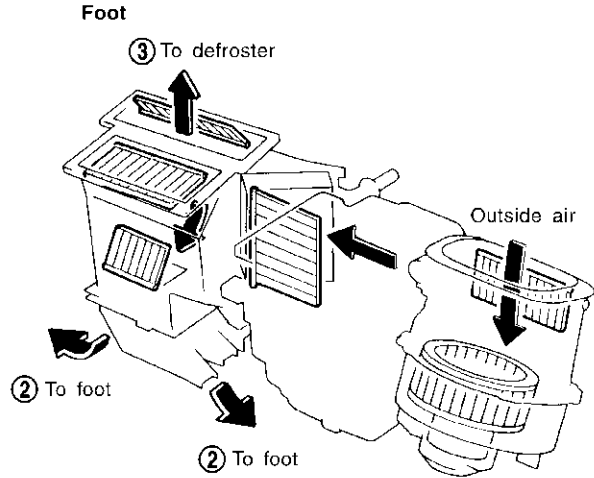
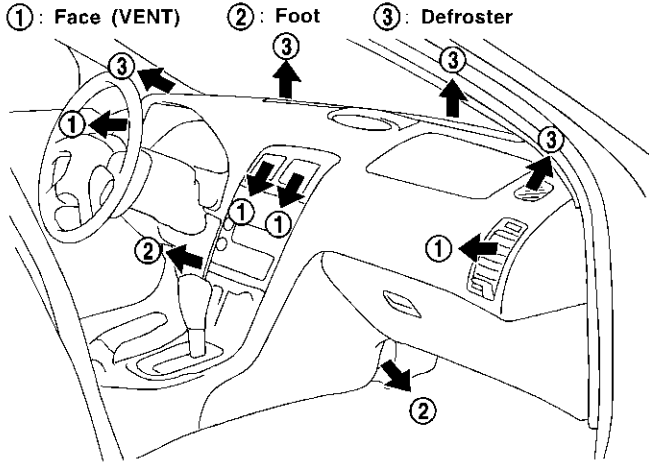

Face
 (🚗 switch "ON")

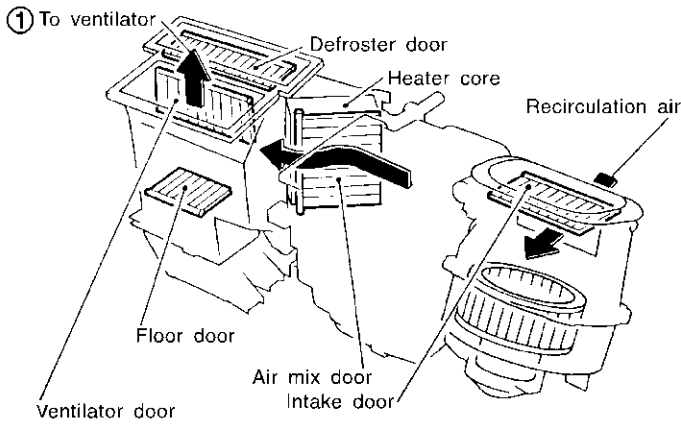

Foot and defroster

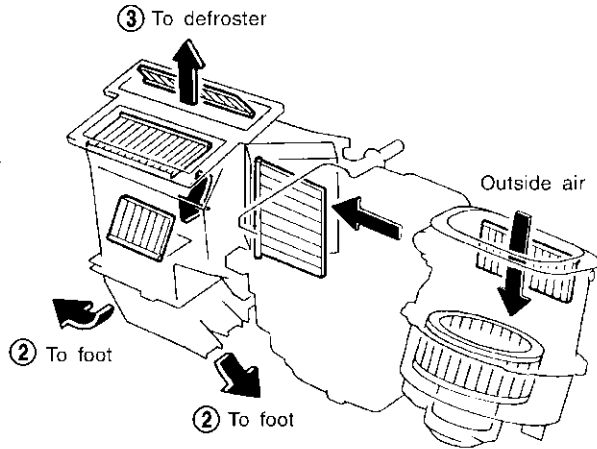

Bi-level
 (🚗 switch "OFF")

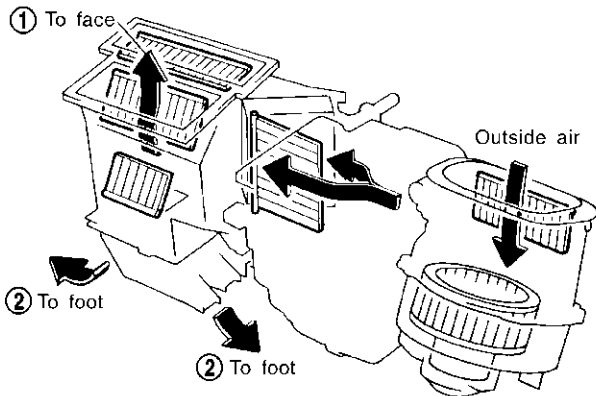

Defroster

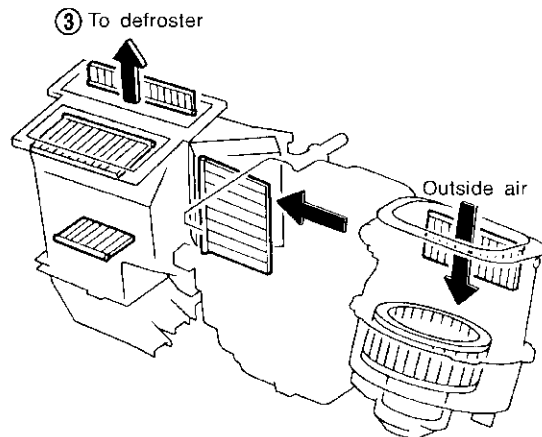

System Description

SWITCHES AND THEIR CONTROL FUNCTIONS

NFHA0246

NFHA0246S01

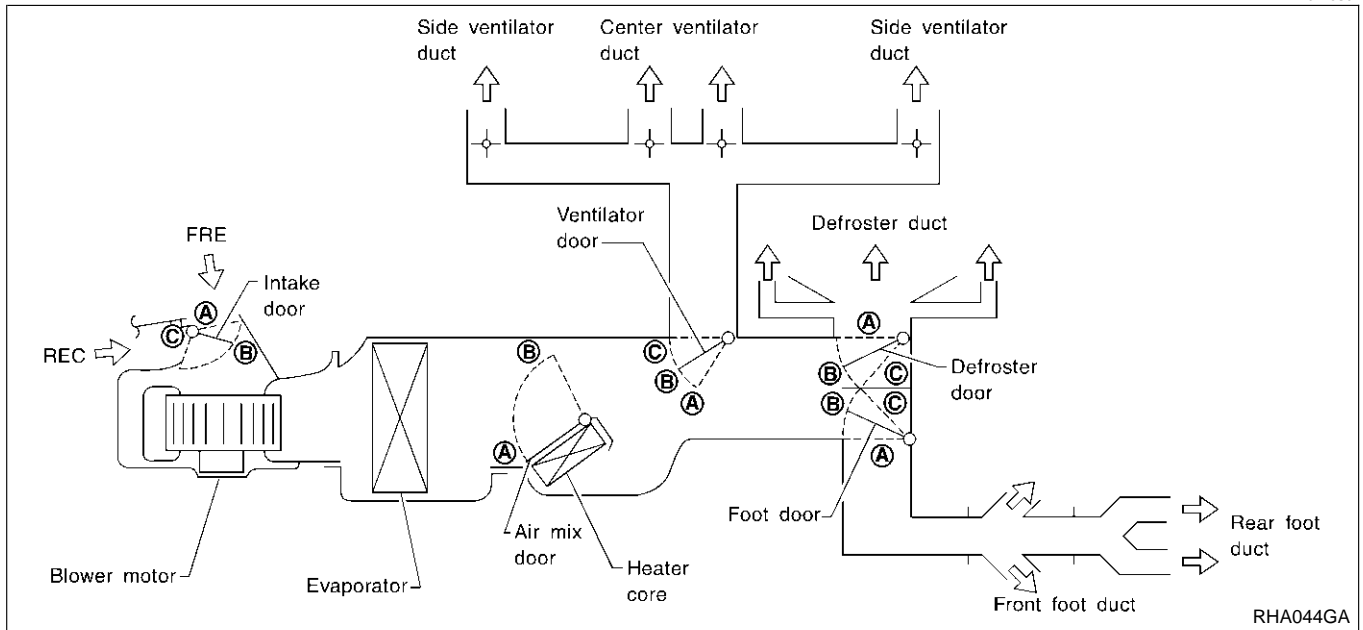

Position or switch	MODE SW				Front DEF SW		AUTO SW	ECON SW	REC SW		Temperature DIAL					
	VENT	B/L	FOOT	D/F	ON	OFF			ON	OFF						
Door							AUTO	ECON			18.0°C (60°F)	—	32.0°C (90°F)			
Ventilator door	A	B	C	C	C	—	AUTO	AUTO	—	—	—					
Foot door	A	B	C	C	A				—	—	—					
Defroster door	A	A	B	C	C				—	—	—					
Air mix door	—				—				—	—	A	AUTO	B	—		
Intake door	—				C				—	A	AUTO*1	—				

*1: Automatically controlled when REC switch is OFF.

GI
MA
EM
LC
EC
FE
CL
MT
AT
AX
SU
BR
ST
RS
BT
HA
SC
EL
IDX

Component Location
ENGINE COMPARTMENT

NFHA0172

NFHA0172S01

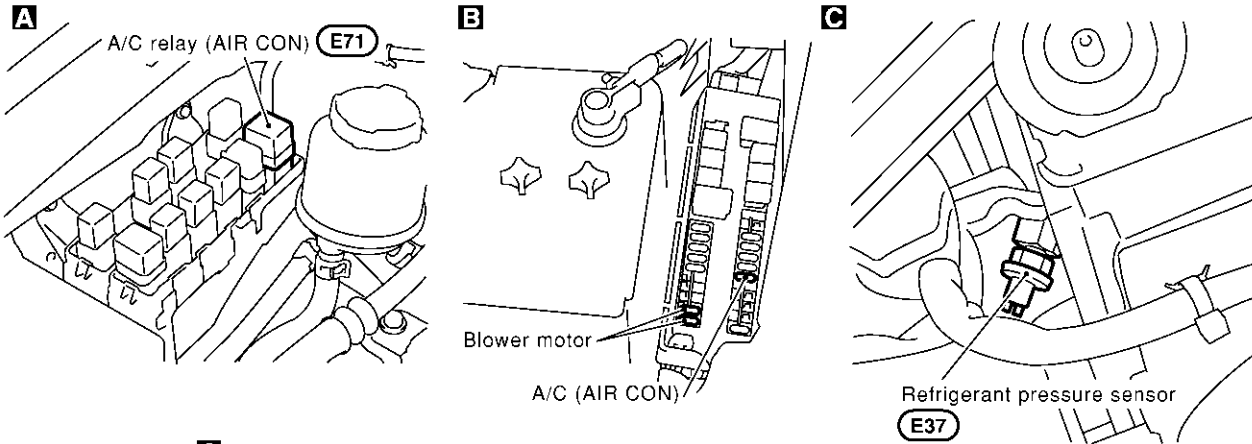

Relay box-1 **A**

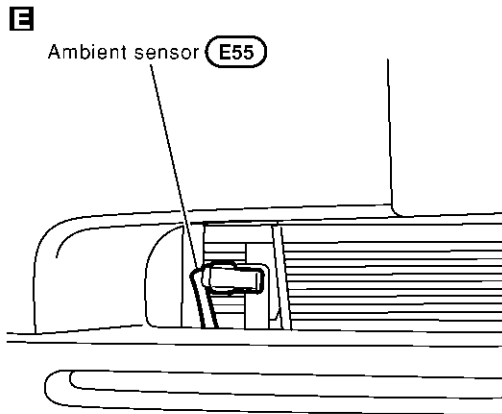
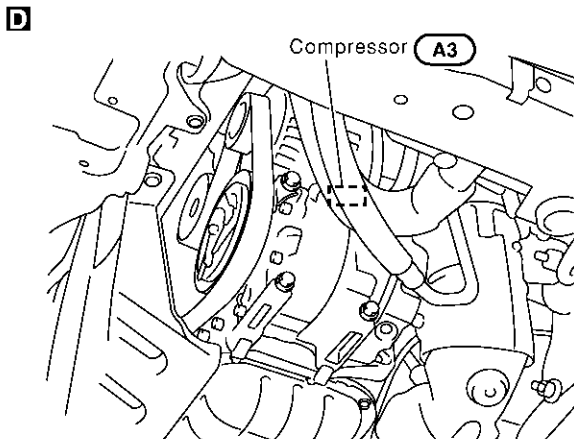
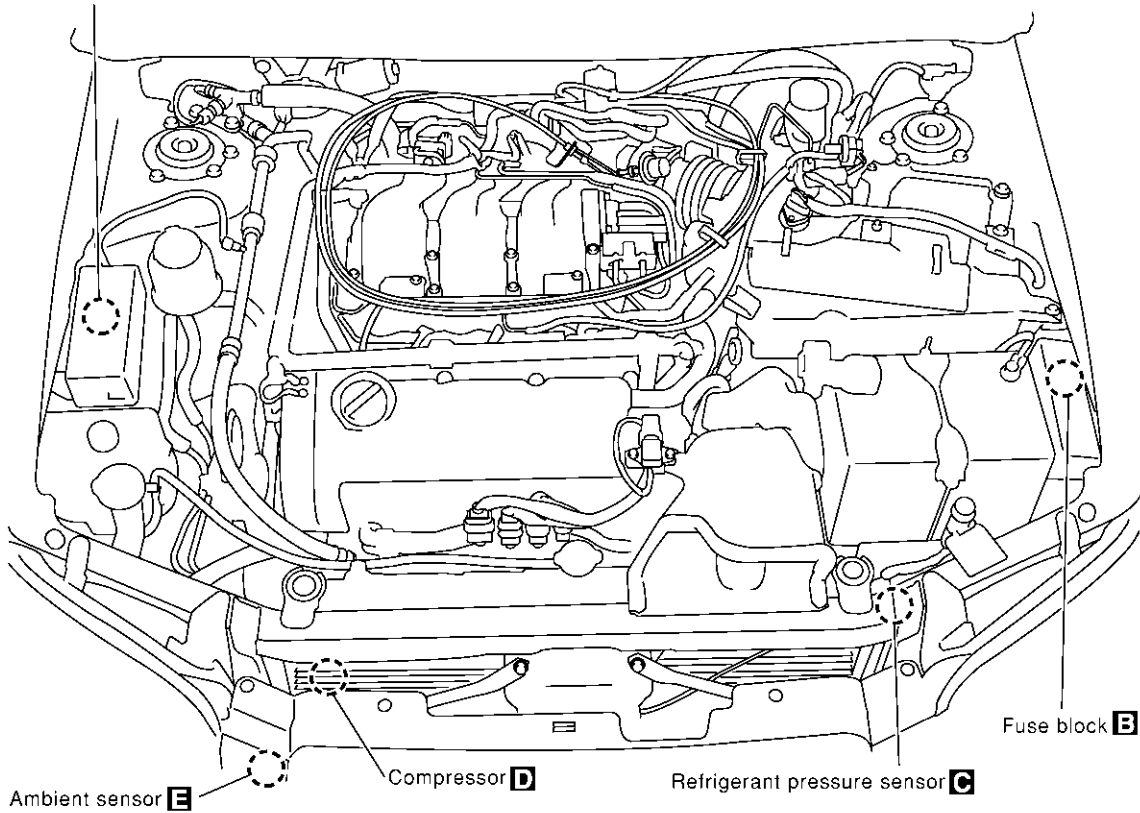

RHA0341

PASSENGER COMPARTMENT

NFHA0172S02

GI
MA
EM
LC
EC
FE
CL
MT
AT
AX
SU
BR
ST
RS
BT
HA
SC
EL
IDX

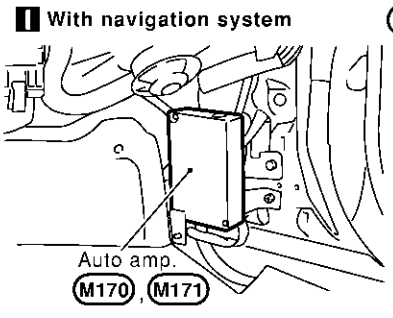
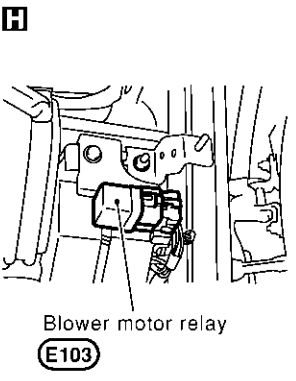
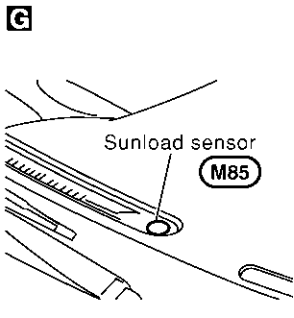
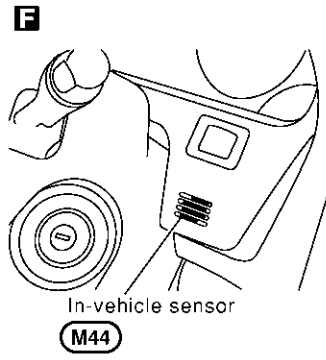
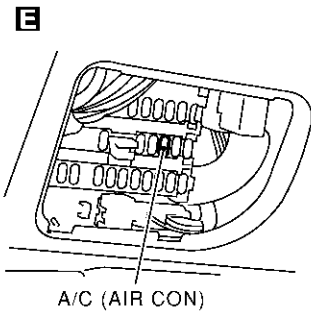
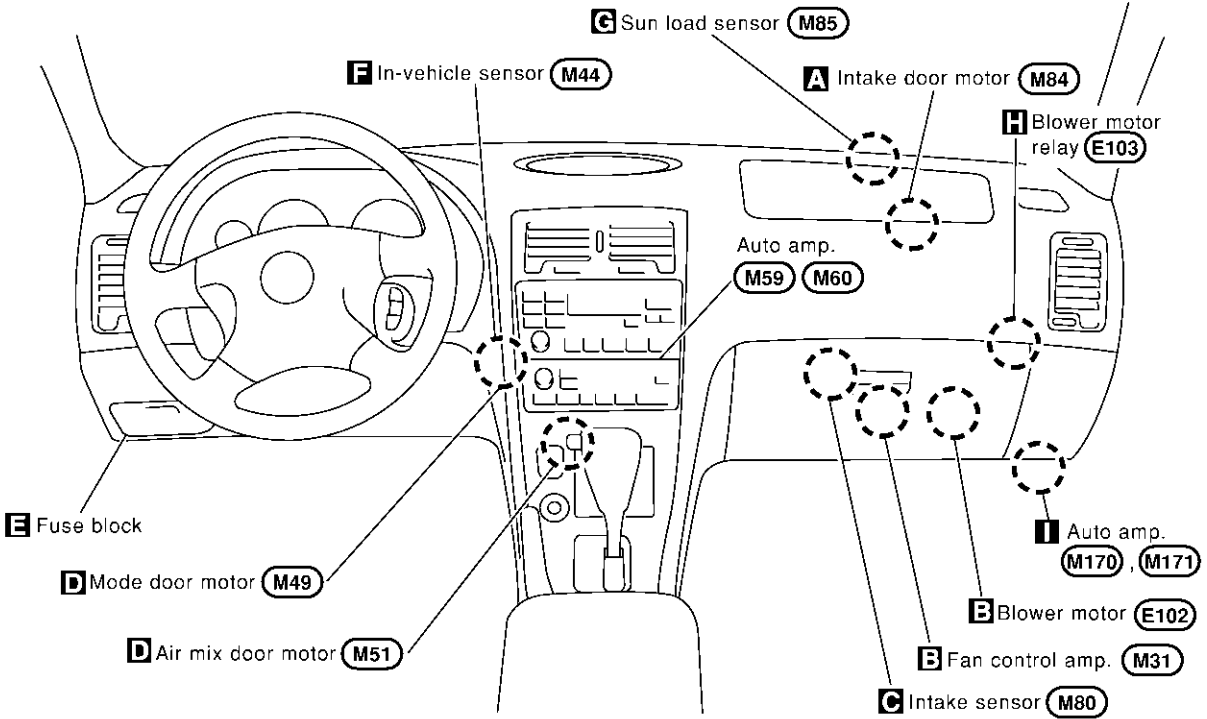
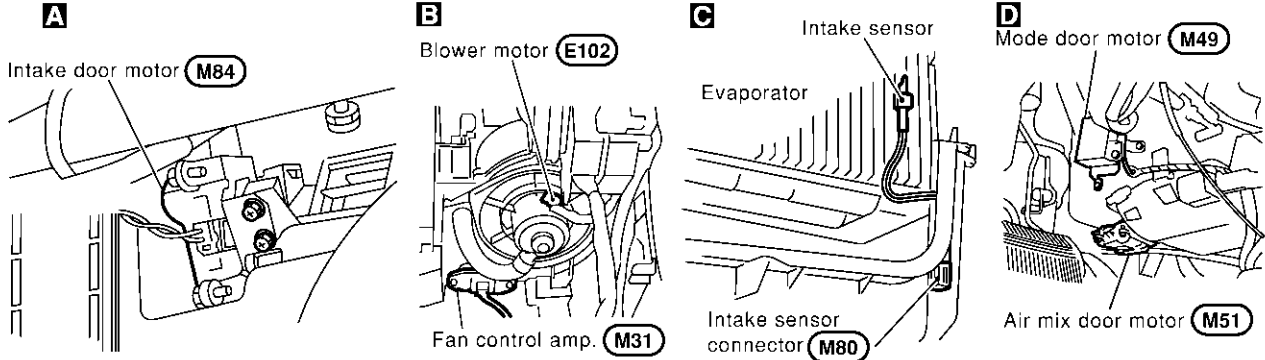

SHA628F

Circuit Diagram (Without Navigation System)

Circuit Diagram (Without Navigation System)

NFHA0173

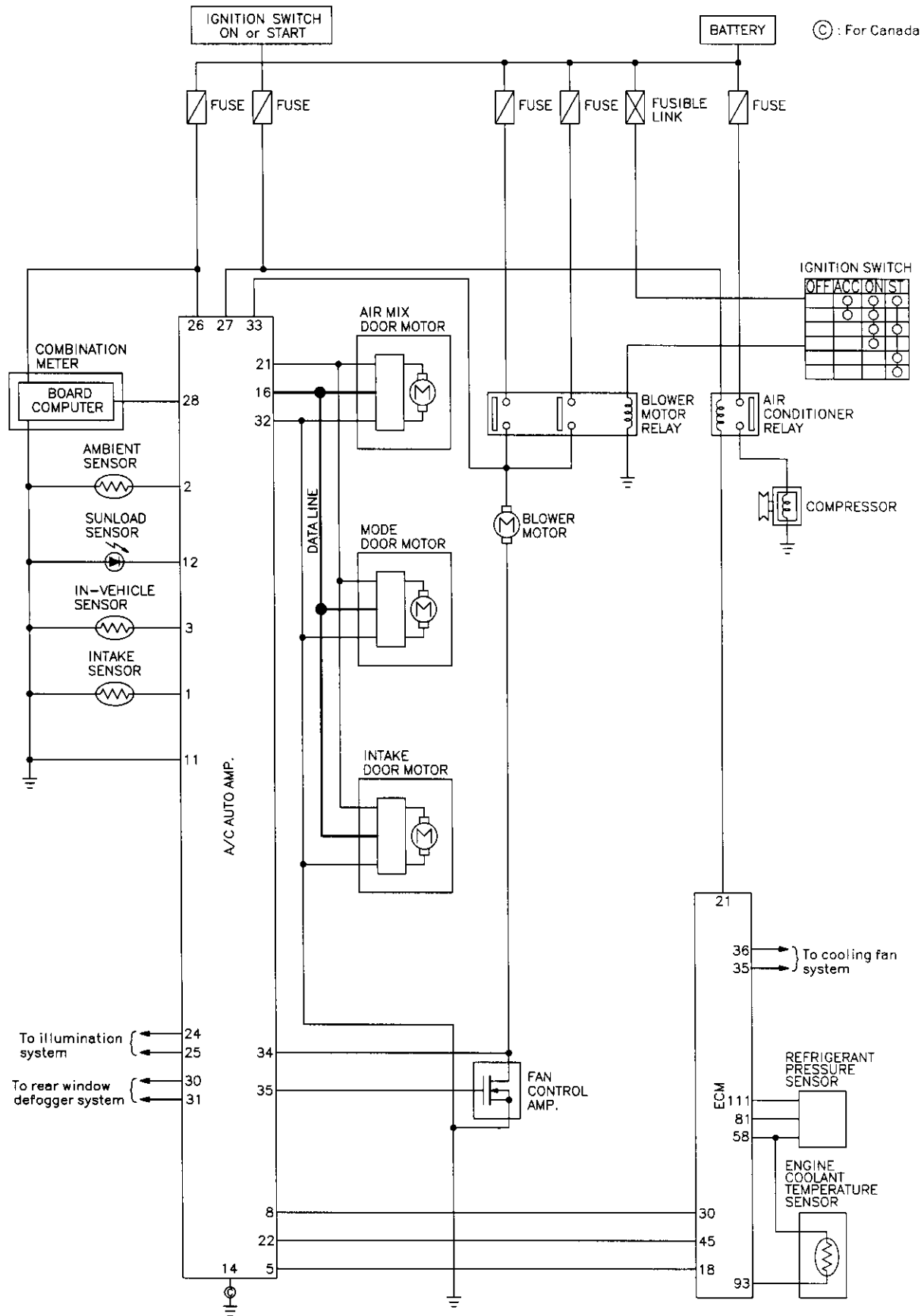

MHA177B

Wiring Diagram — A/C, A —/Without Navigation System

NFHA0174

HA-A/C,A-01

— : DATA LINE

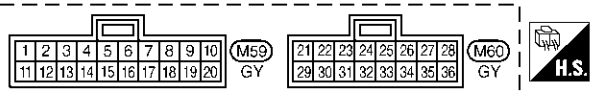
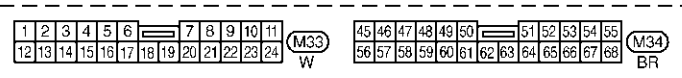
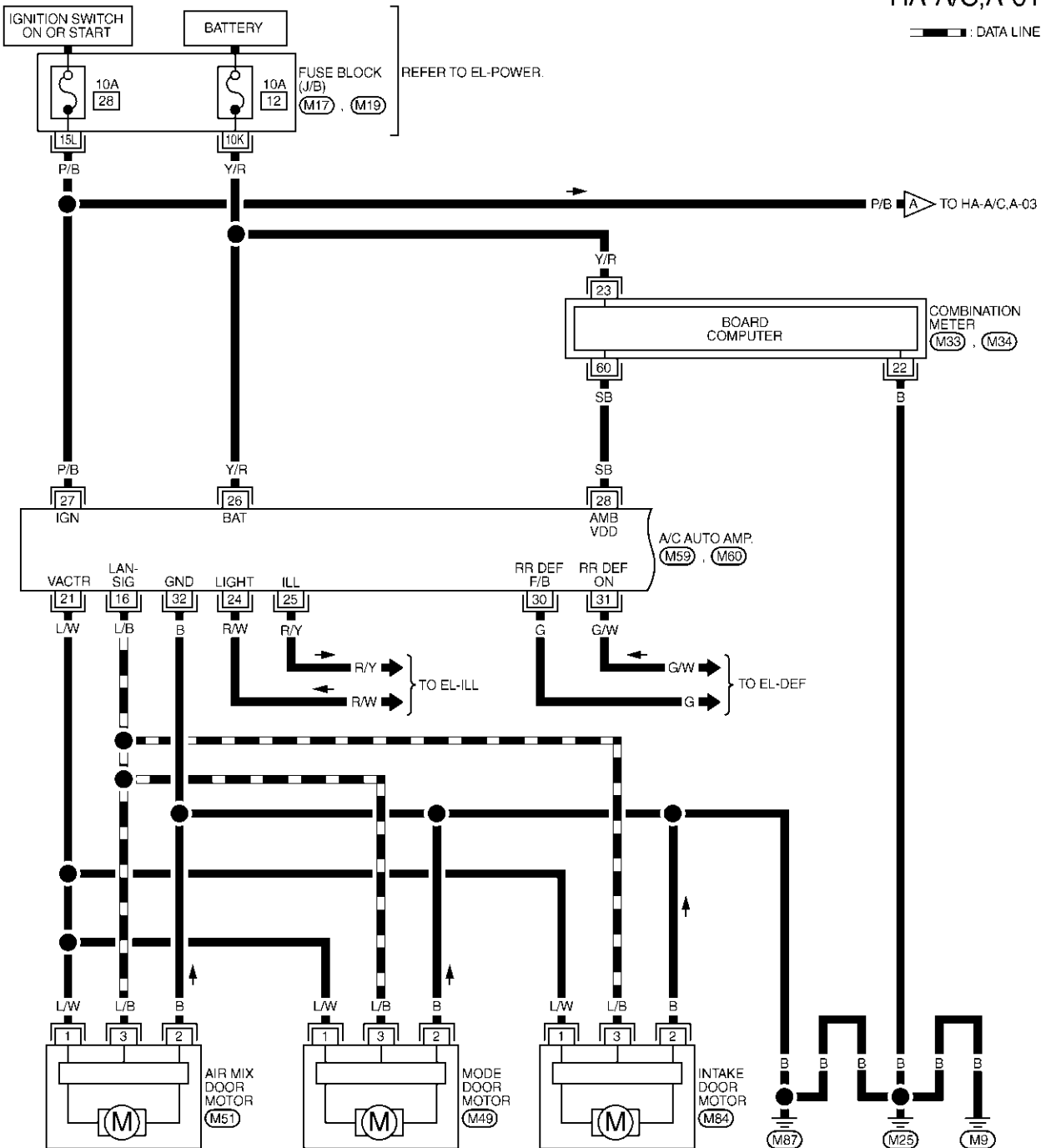

REFER TO THE FOLLOWING.
(M17), (M19) - FUSE BLOCK -
JUNCTION BOX (J/B)

GI
MA
EM
LC
EC
FE
CL
MT
AT
AX
SU
BR
ST
RS
BT
HA
SC
EL
IDX

TROUBLE DIAGNOSES

AUTO

Wiring Diagram — A/C, A —/Without Navigation System (Cont'd)

HA-A/C,A-02

⬡ : FOR CANADA

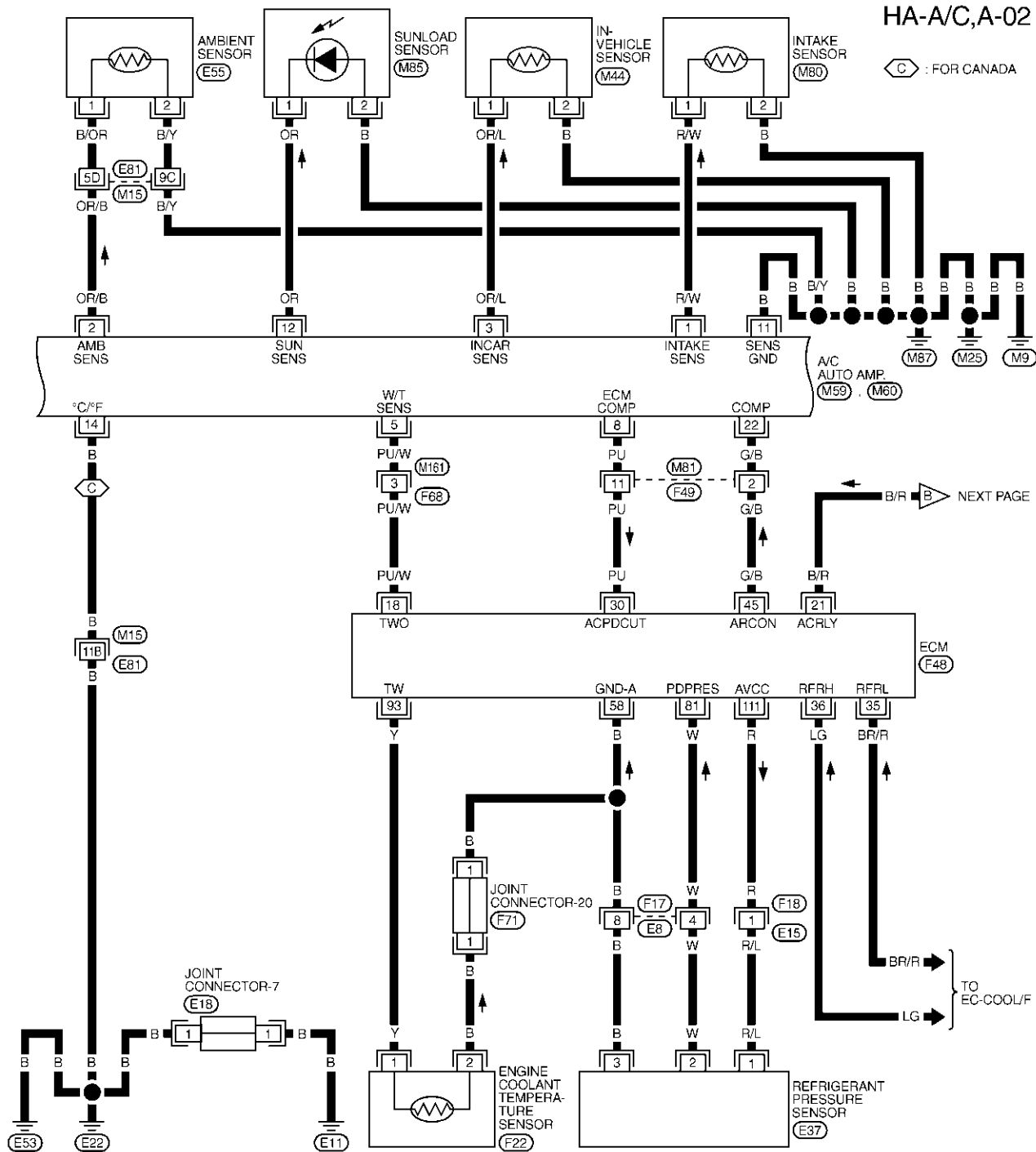

▶ NEXT PAGE

TO EC-COOL/F

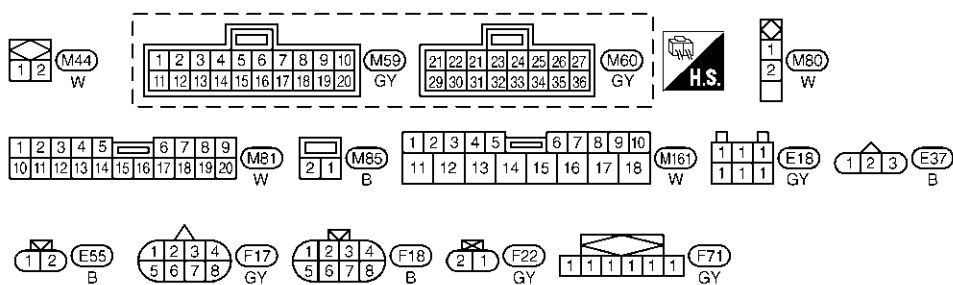

REFER TO THE FOLLOWING:
 (M15) - SUPER
 MULTIPLE JUNCTION (SMJ)
 (F48) - ELECTRICAL UNITS

MHA179B

Circuit Diagram (With Navigation System)

NFHA0282

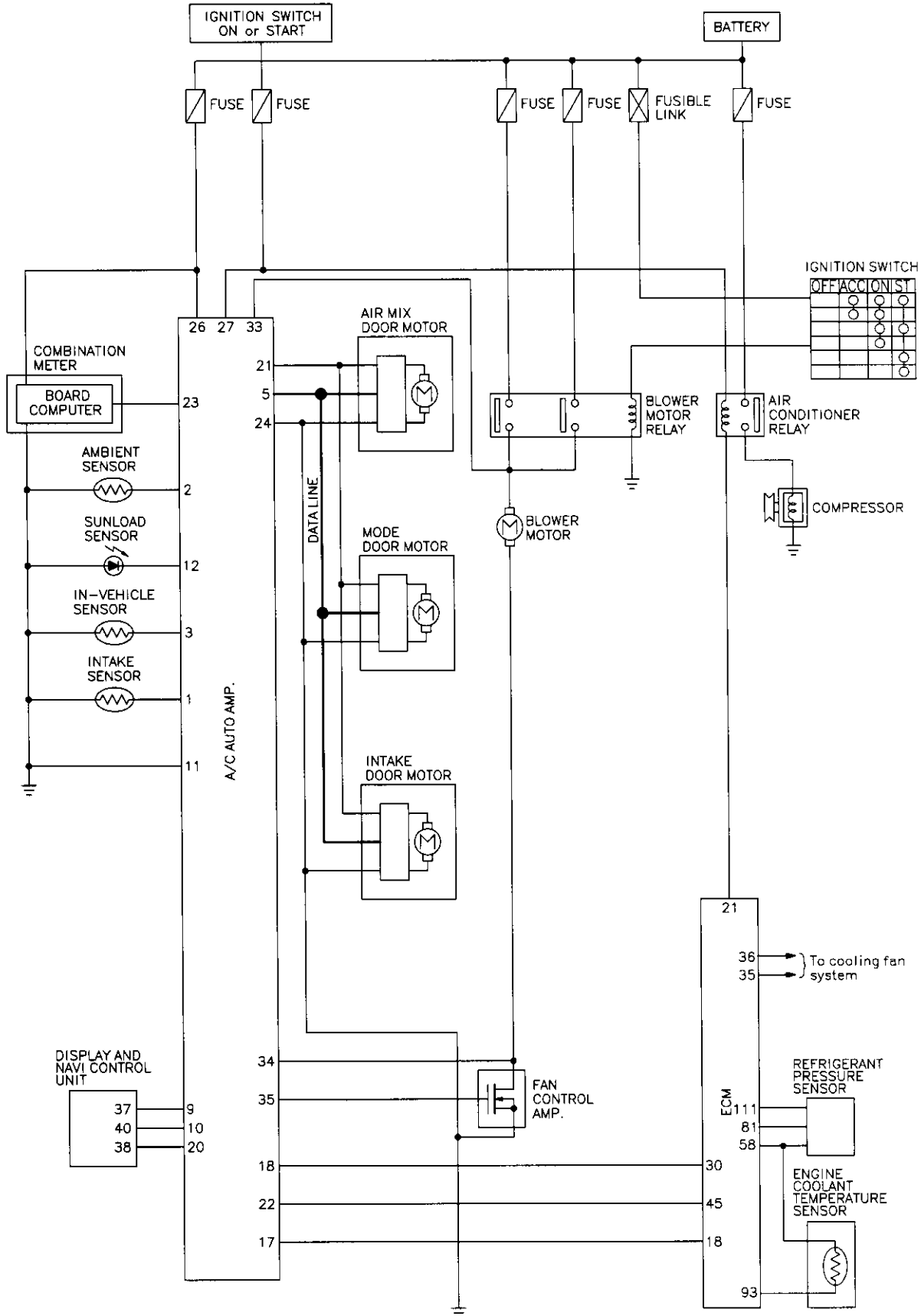

MHA180B

Wiring Diagram — A/C, A —/With Navigation System

NFHA0283

HA-A/C,A-04

— : DATA LINE

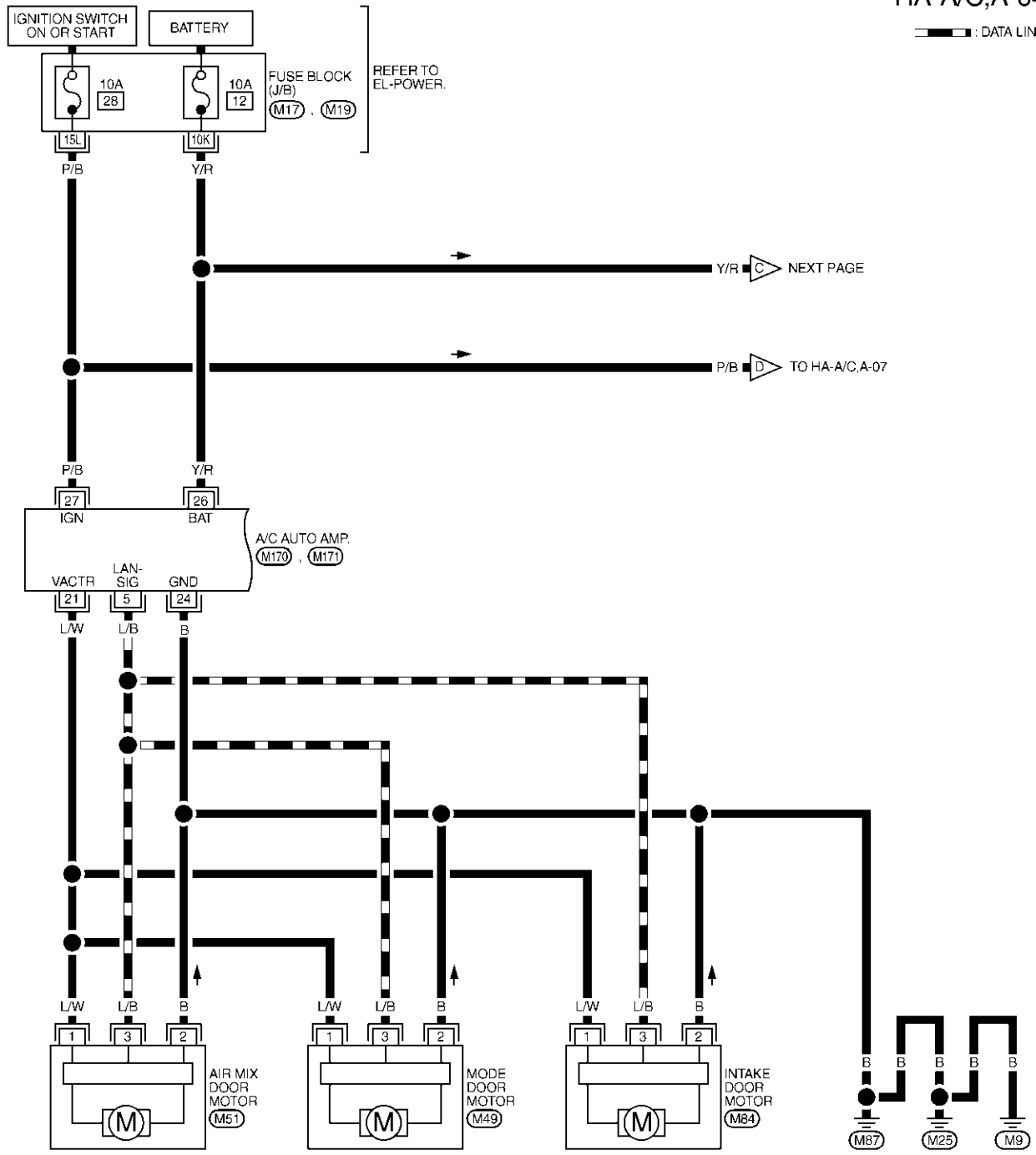

GI
 MA
 EM
 LC
 EC
 FE
 CL
 MT
 AT
 AX
 SU
 BR
 ST
 RS
 BT
HA
 SC
 EL
 IDX

1	(M49)	(M51)	(M84)
2	W	W	W
3			

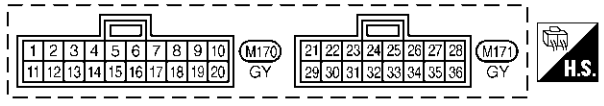

REFER TO THE FOLLOWING.
(M17), **(M19)** - FUSE BLOCK - JUNCTION BOX (J/B)

TROUBLE DIAGNOSES

AUTO

Wiring Diagram — A/C, A —/With Navigation System (Cont'd)

HA-A/C,A-05

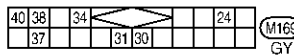
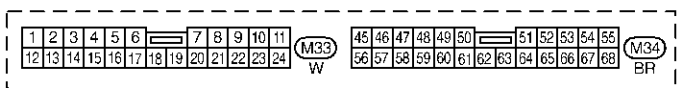
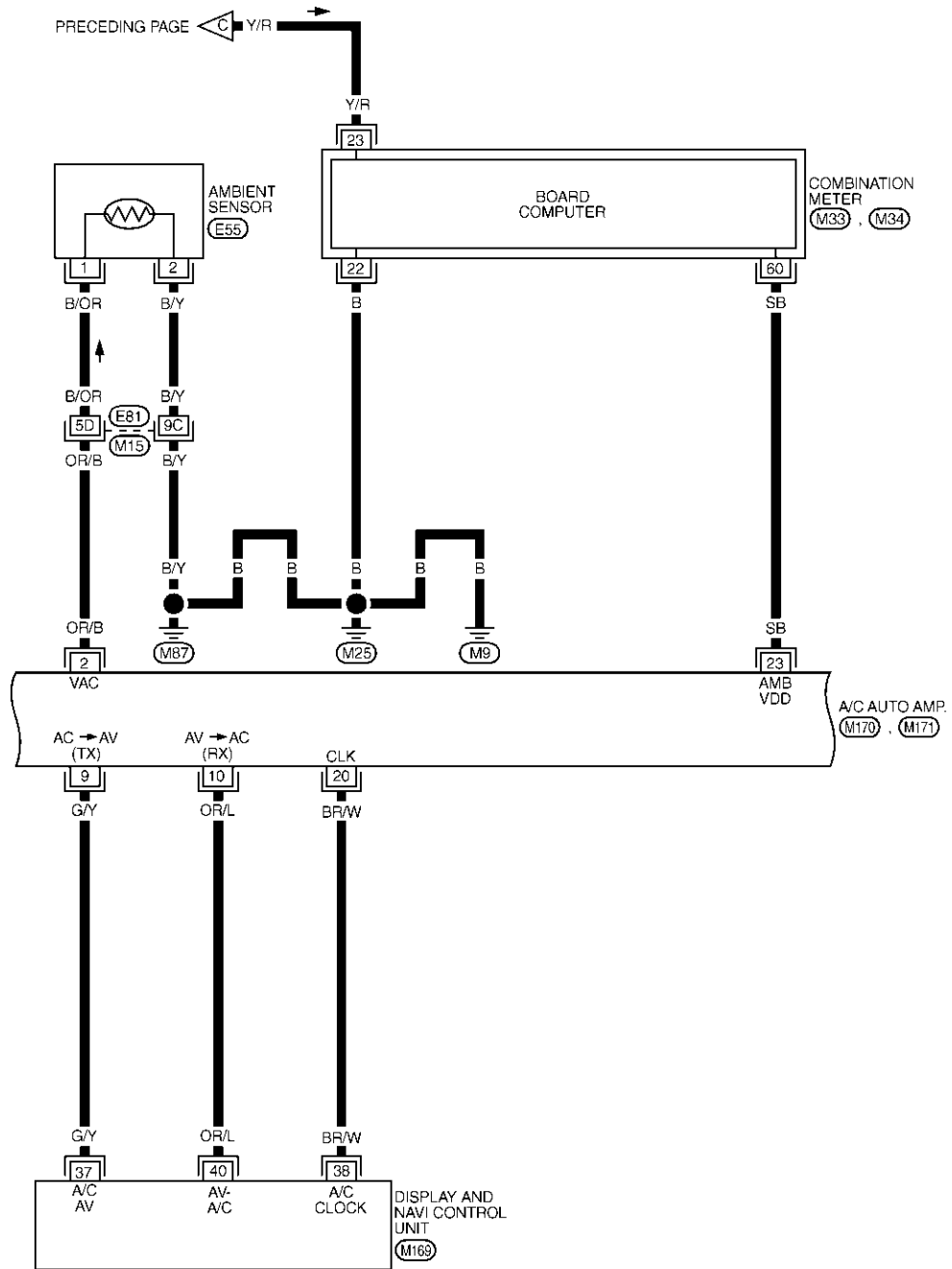

REFER TO THE FOLLOWING:
 (M15) - SUPER
 MULTIPLE JUNCTION (SMJ)

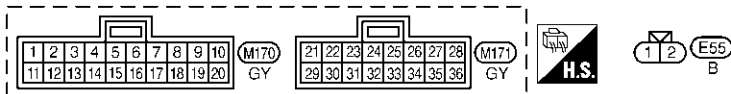

MHA175B

GI
MA
EM
LC
EC
FE
CL
MT
AT
AX
SU
BR
ST
RS
BT
HA
SC
EL
IDX

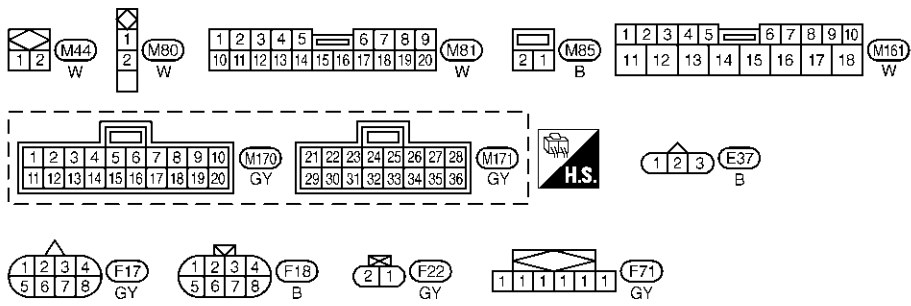
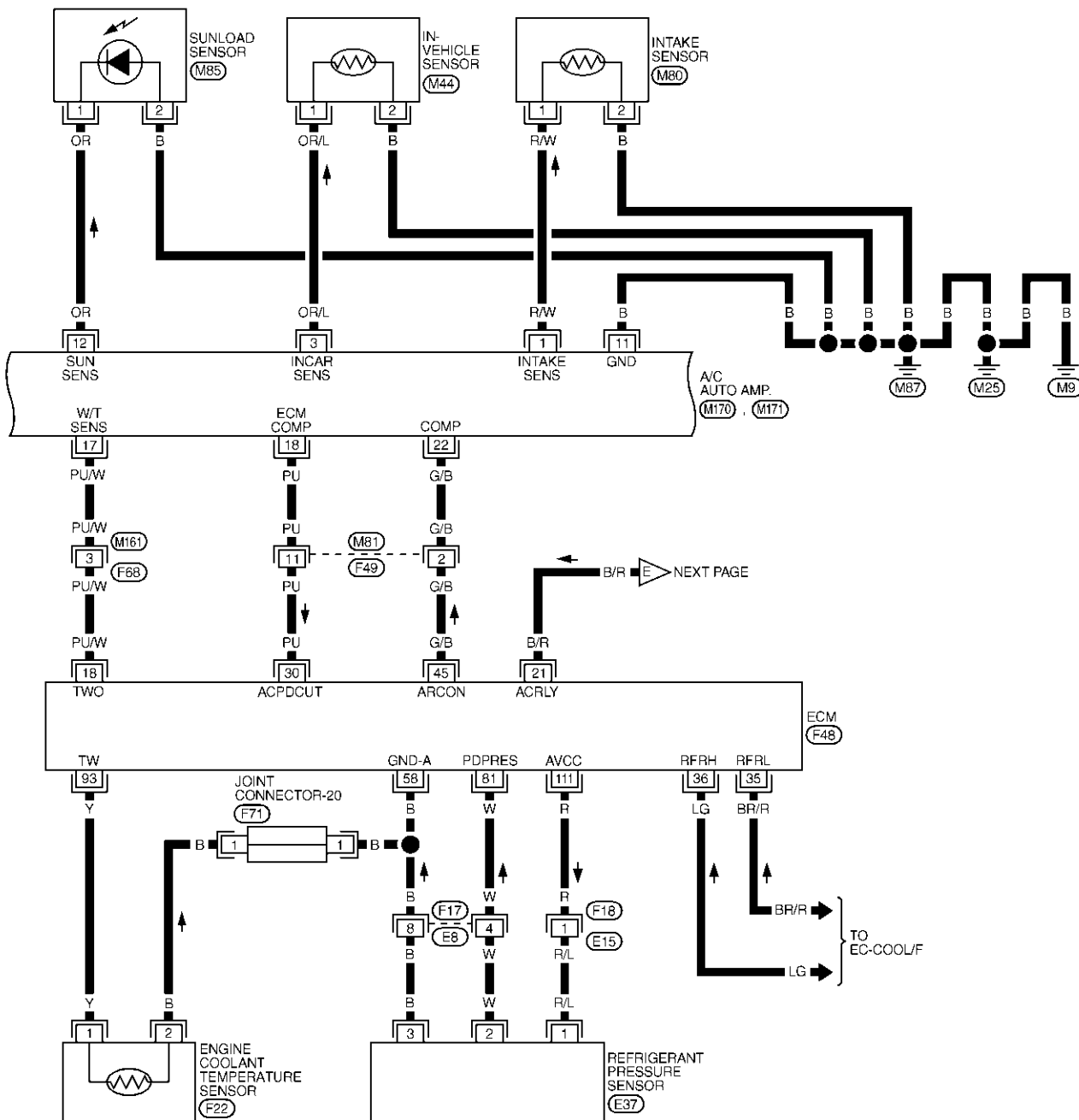

REFER TO THE FOLLOWING.
(F48) - ELECTRICAL UNITS

HA-A/C,A-07

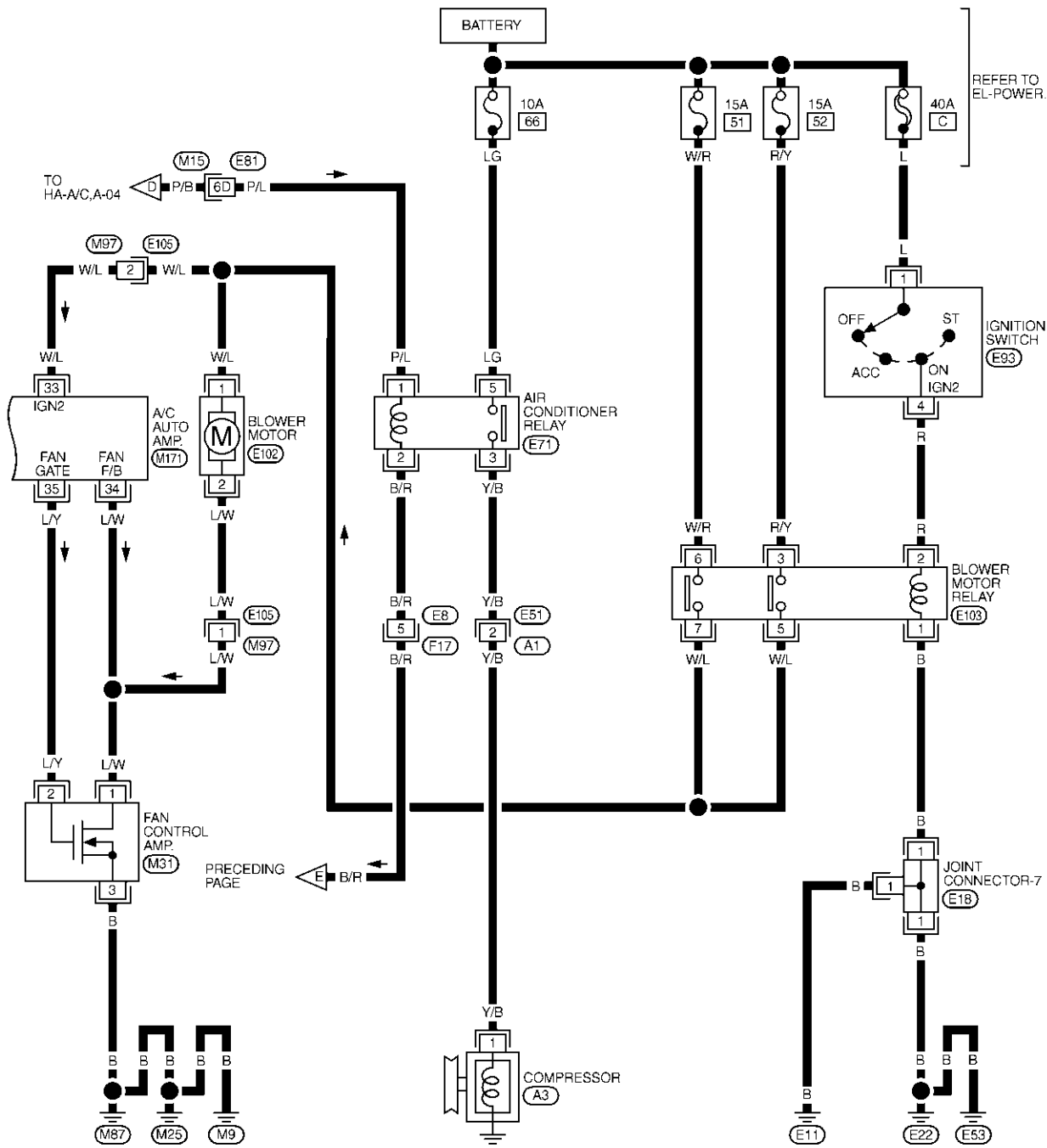

REFER TO EL-POWER.

PRECEDING PAGE

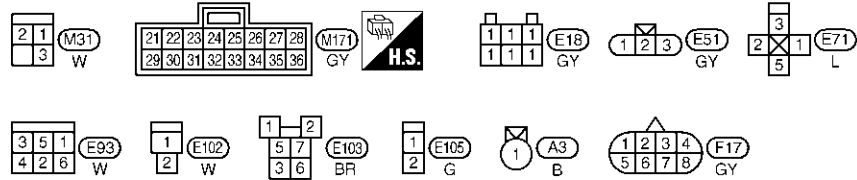

REFER TO THE FOLLOWING:
 (M15) - SUPER
 MULTIPLE JUNCTION (SMJ)

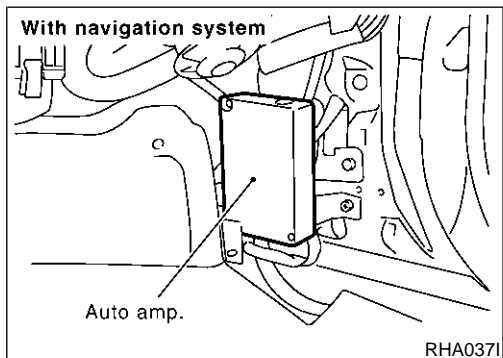
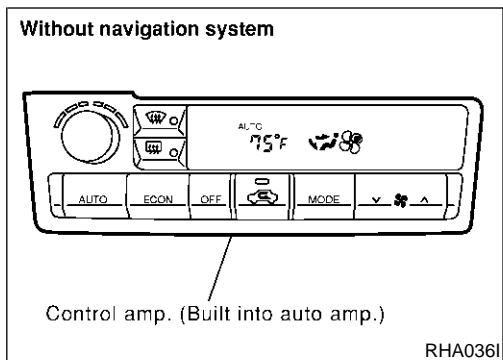

Auto Amp. Terminals and Reference Value
INSPECTION OF AUTO AMP.

NFHA0175

NFHA0175S01

- Measure voltage between each terminal and body ground by following "AUTO AMP. INSPECTION TABLE".

- Pin connector terminal layout

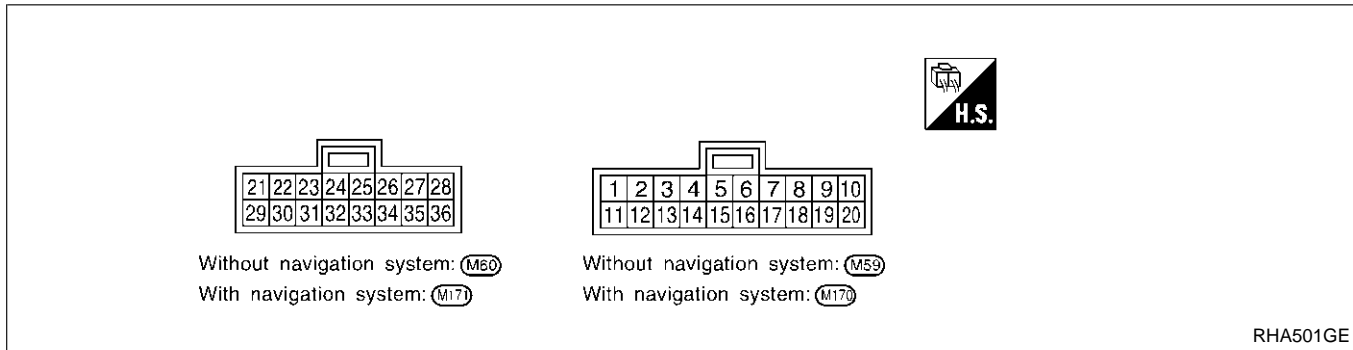

AUTO AMP. INSPECTION TABLE
Without Navigation System

NFHA0175S02

NFHA0175S0201

TERMI- NAL NO.	WIRE COLOR	ITEM	CONDITION	VOLTAGE V
1	R/W	Intake sensor	—	—
2	OR/B	Ambient sensor	—	—
3	OR/L	In-vehicle sensor	—	—
5	PU/W	Water temperature sensor	At idle [after warming up, approx. 80°C (176°F)] NOTE: The waveforms vary depending on coolant temperature.	









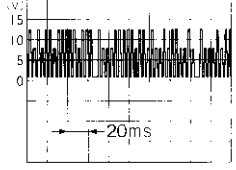

SHA606F

GI
 MA
 EM
 LC
 EC
 FE
 CL
 MT
 AT
 AX
 SU
 BR
 ST
 RS
 BT
HA
 SC
 EL
 IDX

TROUBLE DIAGNOSES

AUTO

Auto Amp. Terminals and Reference Value (Cont'd)

TERMI- NAL NO.	WIRE COLOR	ITEM	CONDITION		VOLTAGE V	
8	PU	Compressor feed back signal		AUTO SW: ON	—	Approximately 0
					When refrigerant pres- sure sensor connector is disconnected	Approximately 5
11	B	Sensor ground		—	Approximately 0	
12	OR	Sunload sensor		—	—	
14	B	Ground (for Canada)		—	Approximately 0	
16	L/B	A/C LAN signal		—	Approximately 5.5	
					 <p style="text-align: right; margin-top: 5px;">HAK0652D</p>	
21	L/W	Power supply for mode door motor, intake door motor and air mix door motor		—	Approximately 12	
22	G/B	Compressor ON sig- nal		Compressor	ON	Approximately 0
					OFF	Approximately 5
24	R/W	Power supply for illu- mination		Lighting switch	OFF	Approximately 0
					1st	Approximately 12
25	R/Y	Illumination ground		—	Approximately 0	
26	Y/R	Power supply for BAT		—	BATTERY VOLTAGE	
27	P/B	Power supply for IGN		—	Approximately 12	
28	SB	Ambient temperature output signal		—	—	
30	G	Rear window defogger feed back		Rear window defogger switch	ON	Approximately 12
					OFF	Approximately 0
31	G/W	Rear window defogger ON signal		Rear window defogger switch	ON	Approximately 0
					OFF	Approximately 12
32	B	Ground		—	Approximately 0	
33	W/L	Power source for ACC		Ignition voltage feed back	Approximately 12	
34	L/W	Blower motor feed back		Fan speed: Low	Approximately 7 - 10	
35	L/Y	Fan control amp. con- trol signal		Fan speed	Low, Middle low or Middle high	Approximately 2.5 - 3.0
					High	Approximately 9 - 10



TROUBLE DIAGNOSES

AUTO

Auto Amp. Terminals and Reference Value (Cont'd)

With Navigation System

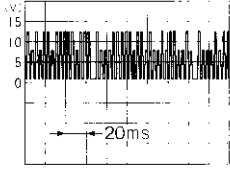
=NFHA0175S0202

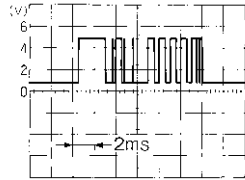
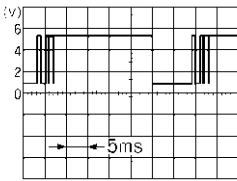
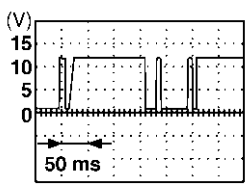
TERMI- NAL NO.	WIRE COLOR	ITEM	CONDITION	VOLTAGE V	
1	R/W	Intake sensor	—	—	GI
2	OR/B	Ambient sensor	—	—	MA
3	OR/L	In-vehicle sensor	—	—	EM
5	L/B	A/C LAN signal	—	Approximately 5.5 	LC EC
				HAK0652D	FE
9	G/Y	Multiplex communica- tion signal (Tx)		— 	CL MT
				JHA645F	AT
10	OR/L	Multiplex communica- tion signal (Rx)	—	— 	AX SU
				JHA646F	BR
11	B	Sensor ground	—	Approximately 0	
12	OR	Sunload sensor	—	—	
17	PU/W	Water temperature sensor	At idle [after warming up, approx. 80°C (176°F)] NOTE: The waveforms vary depending on coolant temperature.		ST RS BT
				SHA606F	

HA

SC



EL

IDX

TROUBLE DIAGNOSES

AUTO

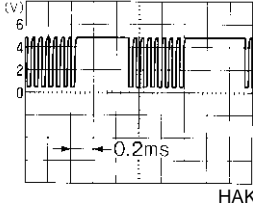
Auto Amp. Terminals and Reference Value (Cont'd)

TERMI- NAL NO.	WIRE COLOR	ITEM		CONDITION	VOLTAGE V	
18	PU	Compressor feed back signal		—	Approximately 0	
				AUTO SW: ON When refrigerant pres- sure sensor connector is disconnected	Approximately 5	
20	BR/W	Multiplex communica- tion signal (CLK)		—	 HAK0363D	
21	L/W	Power supply for each door motor		—	Approximately 12	
22	G/B	Compressor ON signal		Compressor: ON	Approximately 0	
				Compressor: OFF	Approximately 5	
23	SB	Ambient temperature output signal		—	—	
24	B	Ground		—	Approximately 0	
26	Y/R	Power supply for BAT		—	Approximately 12	
27	P/B	Power supply for IGN		—	Approximately 12	
33	W/L	Power supply for ACC		—	Approximately 12	
34	L/W	Blower motor feed back signal		Low	Approximately 7 - 10	
35	L/Y	Fan control amp. con- trol signal		Fan speed	Low, Middle low or Middle high	Approximately 2.5 - 3.0
					High	Approximately 9 - 10

Self-diagnosis

=NFHA0176

INTRODUCTION AND GENERAL DESCRIPTION (WITHOUT NAVIGATION SYSTEM)

NFHA0176S01

The self-diagnostic system diagnoses sensors, door motors, blower motor, etc. by system line. Refer to applicable sections (items) for details. Shifting from normal control to the self-diagnostic system is accomplished by starting the engine (turning the ignition switch from "OFF" to "ON") and pressing "OFF" switch for at least 5 seconds. The "OFF" switch must be pressed within 5 seconds after starting the engine (ignition switch is turned "ON"). This system will be canceled by either pressing **AUTO** (AUTO) switch or turning the ignition switch "OFF". Shifting from one step to another is accomplished by means of pushing TEMP dial right turn or TEMP dial left turn switch, as required.

Additionally shifting from STEP 5 to AUXILIARY MECHANISM is accomplished by means of pushing (fan) UP switch.

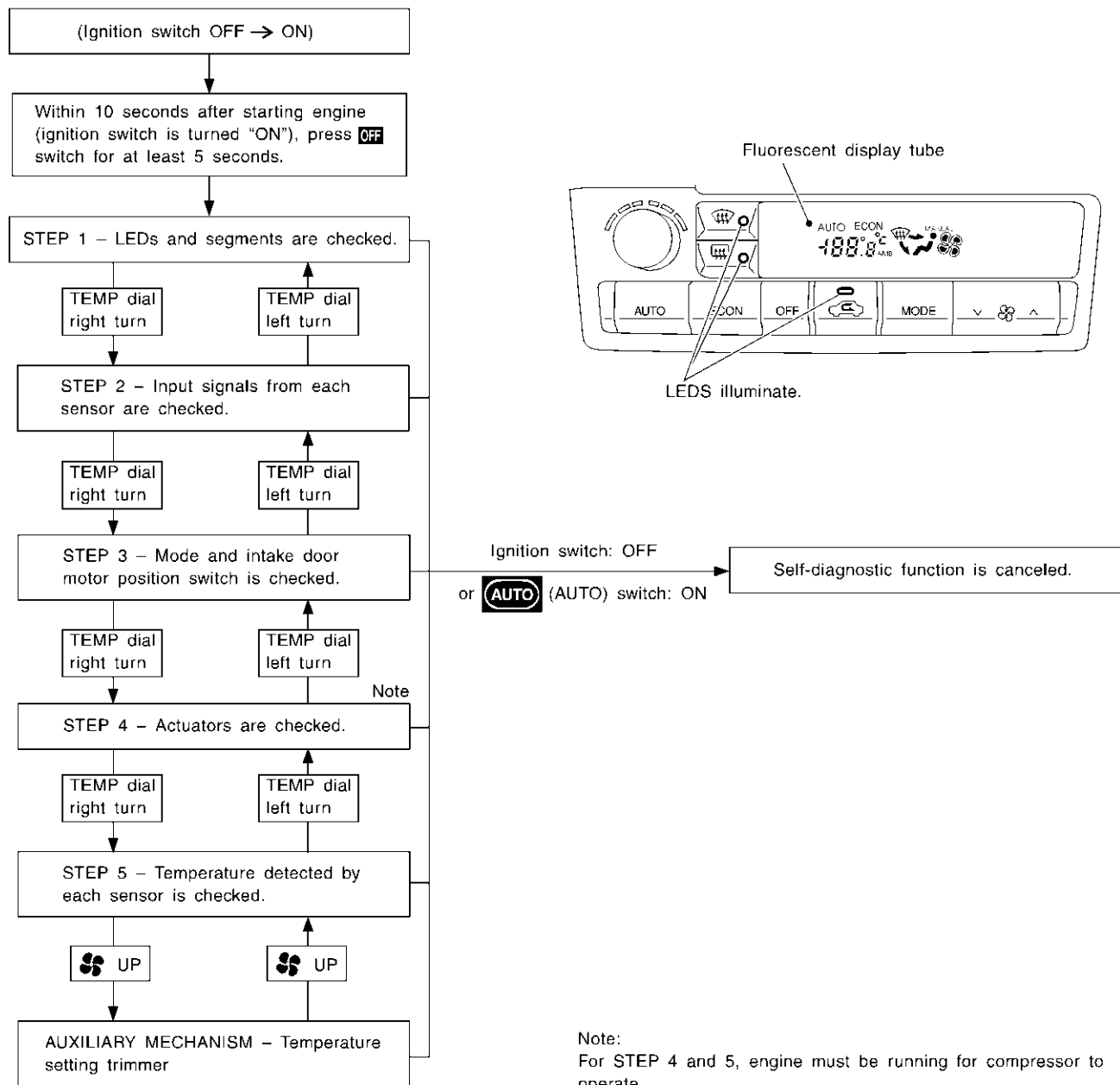

Perform all of the following tests to narrow the problem to a specific assembly, actuator, or function. Link to the Diagnostic Procedure which corresponds to malfunctions noted in these tests. If the A/C display screen has no display, check all power supply circuits to the A/C Auto Amp.

GI
 MA
 EM
 LC
 EC
 FE
 CL
 MT
 AT
 AX
 SU
 BR
 ST
 RS
 BT
HA
 SC
 EL
 IDX

FUNCTION CONFIRMATION PROCEDURE (WITHOUT NAVIGATION SYSTEM)

NFHA0176S02

1	ENTER SELF-DIAGNOSTIC MODE
<p>Perform steps 1 - 3</p> <ol style="list-style-type: none"> 1. Turn the ignition OFF. 2. Start the engine. 3. Immediately after starting the engine press and hold the OFF switch (for the auto A/C system) for at least 5 seconds. The A/C Auto Amp. should now be in self-diagnosis mode. self-diagnosis steps 1 - 5 can now be performed. self-diagnosis step 1 will be displayed first. Shifting from one step to another is accomplished by pressing the temperature increase or decrease switch. 	
▶	GO TO 2.

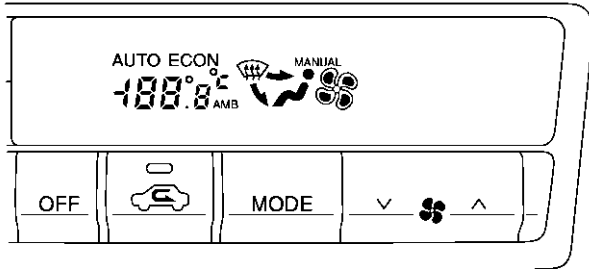
2	STEP 1 - CHECK LED/DISPLAY
<p>Verify all segments illuminate. If all segments do not illuminate the fluorescent display tube is malfunctioning or the system has not entered self diagnosis which would indicate a malfunctioning OFF switch. Do all LEDs and segments illuminate?</p>	
<p>Display malfunction</p> 	
RHA093I	
Yes or No	
Yes	▶ GO TO 3.
No	▶ Malfunctioning OFF switch, LED or fluorescent display tube. Replace A/C auto amp.

3	CHECK TO ADVANCE SELF-DIAGNOSIS STEP 2
<ol style="list-style-type: none"> 1. Turn the TEMP dial clockwise. 2. Advance to self-diagnosis STEP 2. <p>If the system does not shift between step 1 and 2, a malfunctioning TEMP dial is indicated.</p>	
Yes or No	
Yes	▶ GO TO 4.
No	▶ Malfunctioning TEMP dial. Replace A/C auto amp.

4	CHECK TO RETURN SELF-DIAGNOSIS STEP 1	
1. Turn the TEMP dial counterclockwise. 2. Return to self-diagnosis STEP 1. If the system does not shift between step 1 and 2, a malfunctioning TEMP dial is indicated.		
Yes or No		
Yes	▶	GO TO 5.
No	▶	Malfunctioning TEMP dial. Replace A/C auto amp.

GI

MA

EM

LC

5	STEP 2 - SENSOR CIRCUITS ARE CHECKED FOR OPEN OR SHORT CIRCUIT	
Turn the TEMP dial clockwise, advance to STEP 2: Wait (about 25 seconds) for two digit code to appear. This is the electronic sensor input check which includes circuits. Does code No. 20 appear on the display?		
<p>Display (when all sensors are in good order)</p> <p style="margin-left: 100px;">Illuminates 25 seconds after "2" is illuminated.</p> <p style="margin-left: 50px;">Illuminates</p> <div style="text-align: center;">  </div>		
RHA970DB		
Yes or No		
Yes	▶	GO TO 6.
No	▶	GO TO 13.

EC

FE

CL

MT

AT

AX

SU

BR

6	STEP 3 - MODE DOOR AND INTAKE DOOR POSITIONS ARE CHECKED	
Turn the TEMP dial clockwise, advance to STEP 3. Wait (about 50 seconds) for two digit code to appear. This is the mode door and intake door position switch input checks including circuits. Does code No. 30 appear on the display?		
<p>Display (when all doors are in good order)</p> <p style="margin-left: 100px;">Illuminates 50 seconds after "3" is shown on display.</p> <p style="margin-left: 50px;">Illuminates</p> <div style="text-align: center;">  </div>		
RHA869DD		
Yes or No		
Yes	▶	GO TO 7.
No	▶	GO TO 14.

ST

RS

BT

HA

SC

EL

IDX

Self-diagnosis (Cont'd)

7 STEP 4 - OPERATION OF EACH ACTUATOR IS CHECKED

Turn the TEMP dial clockwise, advance to STEP 4.

Engine running.

This is Heater and A/C system check. Code 41 will be displayed. Use the DEF switch to advance the code number from 41 to 46. After 46, the display will return to code 41 and can be advanced to 46 again.

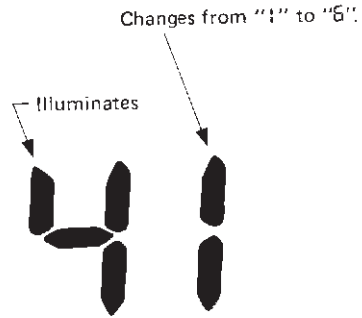

RHA495A



GO TO 8.

8

CHECK ACTUATORS





Confirm operation of system components according to the following charts.
Checks must be made visually, by listening to any noise, or by touching air outlets with your hand, etc. for improper operation.

Code No.	41	42	43	44	45	46
Actuator						
Mode door	VENT	B/L	B/L	FOOT	D/F	DEF
Intake door	REC	REC	20% FRE	FRE	FRE	FRE
Air mix door	Full Cold	Full Cold	Full Hot	Full Hot	Full Hot	Full Hot
Blower motor	4 - 5 V	9 - 11 V	7 - 9 V	7 - 9 V	7 - 9 V	10 - 12 V
Compressor	ON	ON	OFF	OFF	ON	ON

MTBL0314

Operating condition of each actuator cannot be checked by indicators.

Discharge air flow

Mode switch	Air outlet/distribution		
	Face	Foot	Defroster
	100%	—	—
	60%	40%	—
	—	80%	20%
	—	60%	40%
	—	—	100%

MTBL0128

OK or NG

OK



GO TO 9.

NG



- Air outlet does not change.
Go to "Mode Door Motor" (HA-75).
- Intake door does not change.
Go to "Intake Door Motor" (HA-87).
- Discharge air temperature does not change.
Go to "Air Mix Door Motor" (HA-83).
- Blower motor operation is malfunctioning.
Go to "Blower Motor" (HA-91).
- Magnet clutch does not engage.
Go to "Magnet Clutch" (HA-101).

GI

MA

EM

LC

EC

FE

CL

MT

AT

AX

SU

BR

ST

RS

BT

HA

SC

EL

IDX

Self-diagnosis (Cont'd)

9	STEP 5 - TEMPERATURE OF EACH SENSOR IS CHECKED
<p>Turn the TEMP dial clockwise, advance to STEP 5. This is Intake sensor, In Vehicle sensor and Ambient Sensor function check. Code 51 will be displayed.</p> <p>NOTE: Each sensor reading should be approximately the actual temperature.</p> <p style="text-align: center;">"51" appears on display.</p> <div style="text-align: center;">  </div> <p style="text-align: right;">RHA359H</p>	
▶	GO TO 10.

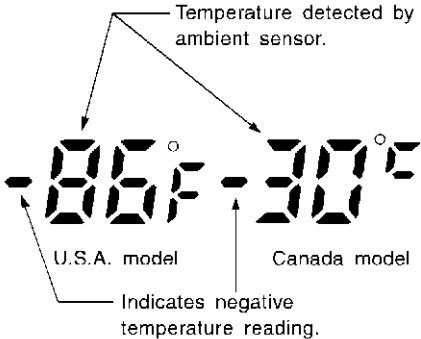
10	CHECK AMBIENT SENSOR
<p>Press DEF once, temperature detected by the Ambient Sensor is displayed.</p> <div style="text-align: center;">  </div> <p style="text-align: center;">OK or NG</p> <p style="text-align: right;">RHA499G</p>	
OK	▶ GO TO 11.
NG	▶ Go to Ambient Sensor Circuit (HA-124).

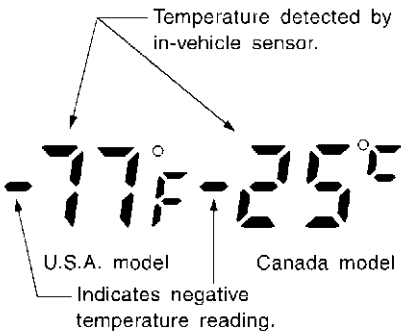
11	CHECK IN-VEHICLE SENSOR
<p>Press DEF second time, temperature detected by the In-vehicle Sensor is displayed.</p> <div style="text-align: center;">  </div> <p style="text-align: center;">OK or NG</p> <p style="text-align: right;">RHA500G</p>	
OK	▶ GO TO 12.
NG	▶ Go to In-vehicle Sensor Circuit (HA-127).

TROUBLE DIAGNOSES

AUTO

Self-diagnosis (Cont'd)

12	CHECK INTAKE SENSOR	
Press DEF third time, temperature detected by the Intake Sensor is displayed.		
<div style="text-align: center;"> <p>Temperature detected by intake sensor.</p> <p>U.S.A. model Canada model</p> <p>Indicates negative temperature reading.</p> </div> <p style="text-align: right;">RHA500GD</p> <p style="text-align: center;">OK or NG</p>		
OK	▶	<ol style="list-style-type: none"> 1. Press (DEF) switch the fourth time. Display returns to original presentation 51. 2. Turn ignition switch OFF or (AUTO) switch ON. 3. END
NG	▶	Go to Intake Sensor Circuit (HA-134).

GI
MA
EM
LC
EC
FE
CL
MT
AT
AX
SU
BR
ST
RS
BT
HA
SC
EL
IDX

13 CHECK MALFUNCTIONING SENSOR

NOTE:

- A blinking mark (-) preceding the Code No. indicates a short circuit.
- If 2 or more items are malfunctioning the corresponding codes will alternately blink twice.
- A circuit will be detected as open or shorted and its code No. will be displayed when input signals correspond with conditions in the following chart.

Code No.	Sensor	Open circuit	Short circuit	Reference page
21	Ambient sensor	Less than -43.8°C (-47°F)	Greater than 100°C (212°F)	*3
-21				
22	In-vehicle sensor	Less than -43.8°C (-47°F)	Greater than 100°C (212°F)	*4
-22				
24	Intake sensor	Less than -43.8°C (-47°F)	Greater than 100°C (212°F)	*5
-24				
25	Sunload sensor*2	Less than 0.228 mA	Greater than 0.98 mA	*6
-25				
26	PBR*1	Greater than 95%	Less than 5%	*7
-26				

MTBL1185

*1: "95%" and "5%" refer to percentage with respect to stroke of air mix door. (Full cold: 0%, Full hot: 100%)

 *2: **Conduct self-diagnosis STEP 2 under sunshine.**

When conducting indoors, direct light (more than 60W) at sunload sensor.

*3: HA-124, *4: HA-127, *5: HA-134, *6: HA-130, *7: HA-136

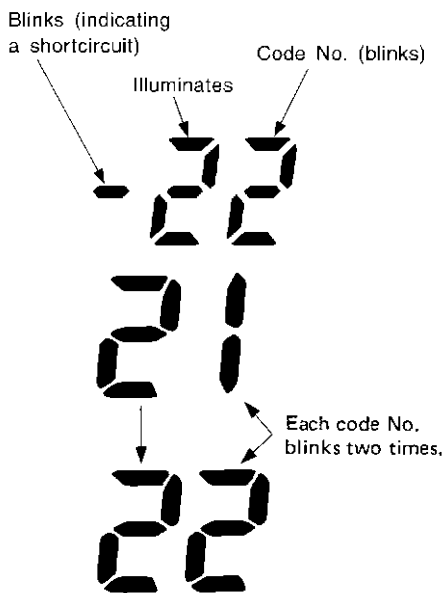
Display (when sensor malfunctions)

RHA455G

RHA501A

INSPECTION END

14	CHECK MALFUNCTIONING DOOR MOTOR POSITION SWITCH
<p>30- Mode door and intake door position switches are in working order. Continue ot next step.</p> <p>31- Mode door circuit / switch in vent position switch is malfunctioning.</p> <p>32- Mode door circuit / switch in B/L position switch is malfunctioning.</p> <p>34- Mode door circuit / switch in Foot position switch is malfunctioning.</p> <p>35- Mode door circuit / switch in Foot Def. position switch is malfunctioning.</p> <p>36- Mode door circuit / switch in Def. position switch is malfunctioning.</p> <p>37- Intake door mode circuit / switch in Fresh Air position is malfunctioning.</p> <p>38- Intake door mode circuit / switch in 20% Fresh Air position is malfunctioning.</p> <p>39- Intake door mode circuit / switch in Recirculation Air position is malfunctioning.</p> <p>NOTE:</p> <ul style="list-style-type: none"> ● If 2 or more items are malfunctioning, the corresponding codes will alternately blink twice. ● If the Mode Door Motor harness is disconnected, repeated display pattern of 31 → 32 → 34 → 35 → 36 will occur. ● If Intake Door Motor harness is disconnected, repeated display pattern of 37 → 38 → 39 will occur. ● If any Mode Door Motor Position Switch is malfunctioning, the Mode Door Motor will also malfunction. <div style="text-align: center; margin-top: 20px;"> <p>Display (when a door is out of order)</p> <p style="margin-left: 100px;">Illuminates</p> <p style="margin-left: 150px;">Code No. (blinks)</p> <p style="margin-left: 100px;">Each code No. blinks two times.</p> </div> <div style="text-align: right; margin-top: 10px;"> <p>RHA168DA</p> <p>RHA498A</p> </div>	<p>GI</p> <p>MA</p> <p>EM</p> <p>LC</p> <p>EC</p> <p>FE</p> <p>CL</p> <p>MT</p> <p>AT</p> <p>AX</p> <p>SU</p> <p>BR</p> <p>ST</p> <p>RS</p> <p>BT</p> <p style="background-color: black; color: white; padding: 5px;">HA</p> <p>SC</p> <p>EL</p> <p>IDX</p>
▶	INSPECTION END

Self-diagnosis (Cont'd)

AUXILIARY MECHANISM: TEMPERATURE SETTING TRIMMER (WITHOUT NAVIGATION SYSTEM)

=NFHA0176S03

Unconfirmed Incidents

NFHA0176S0301

The customer may feel that the cabin temperature is not being controlled or regulated to the temperature indicated by the auto A/C display screen. To satisfy individual driver preference the Temperature Setting Trimmer may be used to compensate in a range of $\pm 3^{\circ}\text{C}$ ($\pm 6^{\circ}\text{F}$).

1. Enter Self Diagnosis mode and select STEP 5.
2. Press the Fan Up  switch: This will set the A/C system in auxiliary mode and the display will show 61.
3. Turn the temperature dial clockwise or counterclockwise: The temperature will change at a rate of 0.5°C (1°F).

If power is lost to the A/C Auto Amp. trimmer setting is canceled and setting becomes that of initial condition, 0°C (0°F).

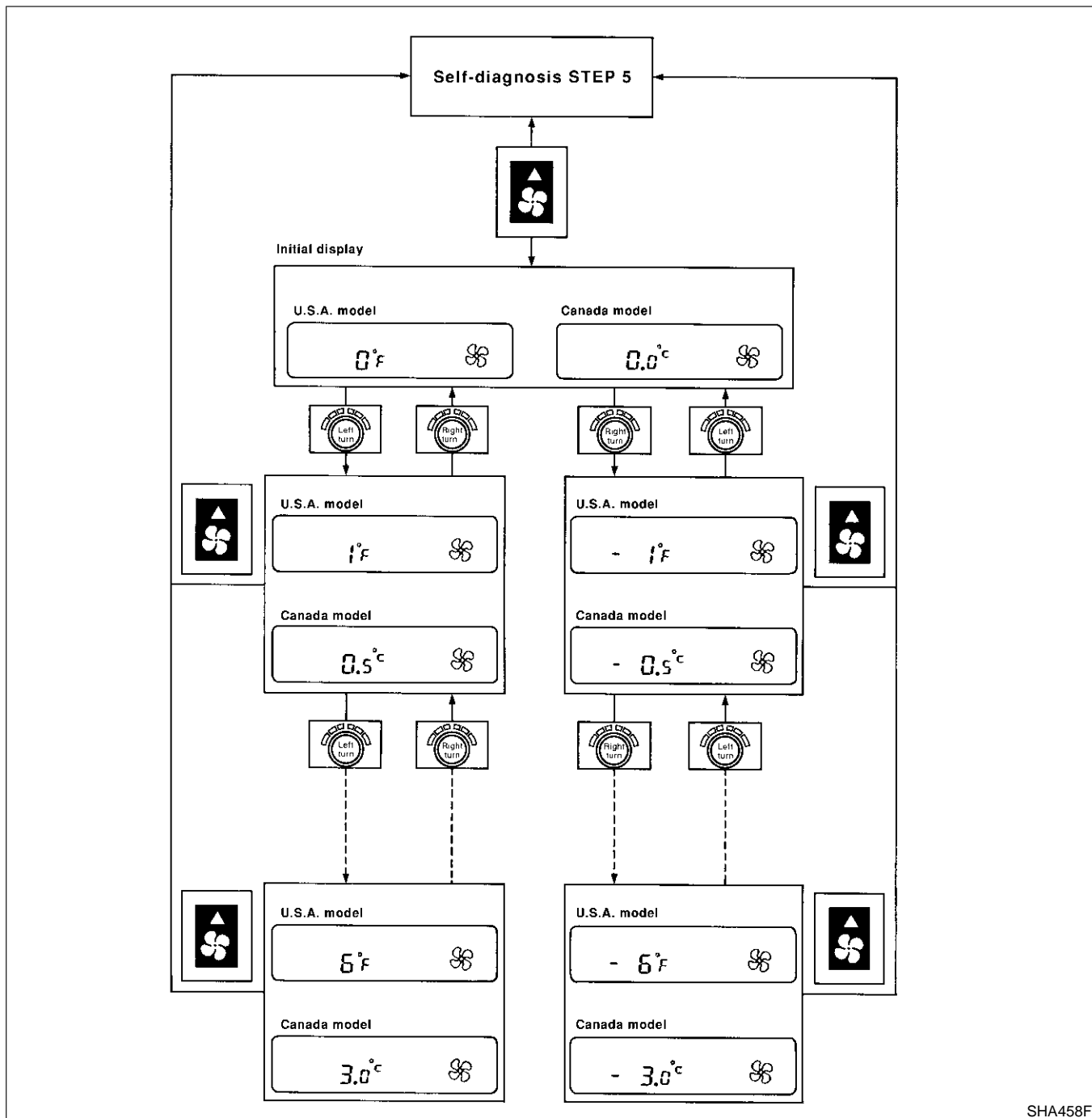

SHA458F

When battery cable is disconnected, trimmer operation is canceled. Temperature set becomes that of initial condition, i.e. 0°C (0°F).

INTRODUCTION AND GENERAL DESCRIPTION (WITH NAVIGATION SYSTEM)

NFHA0176S07

The self-diagnostic system diagnoses sensors, door motors, blower motor, etc. by system line. Refer to applicable sections (items) for details. Shifting from normal control to the self-diagnostic system is accomplished by starting the engine (turning the ignition switch from "OFF" to "ON") and pressing "OFF" switch for at least 5 seconds. The "OFF" switch must be pressed within 10 seconds after starting the engine (ignition switch is turned "ON"). This system will be canceled by either pressing **AUTO** (AUTO) switch or turning the ignition switch "OFF". Shifting from one step to another is accomplished by means of turning temperature dial, as required. Additionally shifting from STEP 5 to AUXILIARY MECHANISM is accomplished by means of pushing  (fan) UP switch.

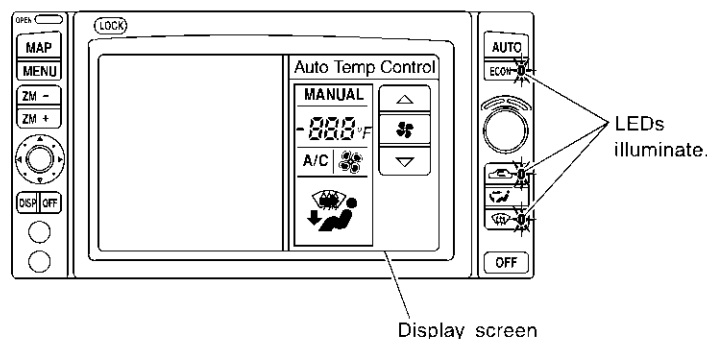
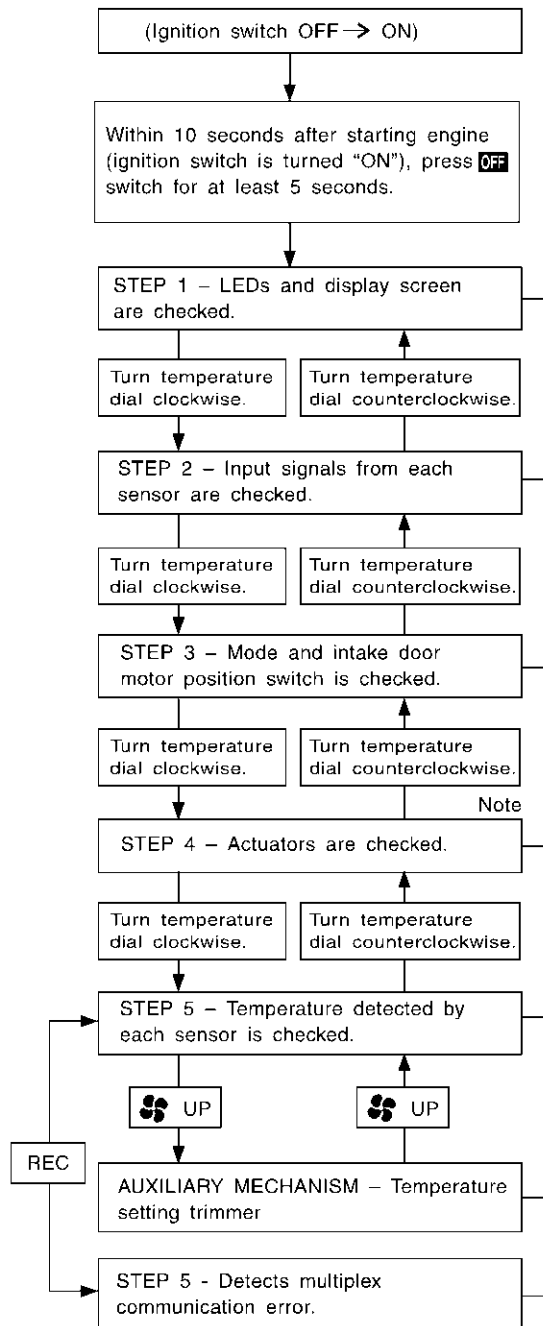

Ignition switch: OFF
 or **AUTO** (AUTO) switch: ON
 or Back switch (Display): Touch

Self-diagnostic function is canceled.

Note:
 For STEP 4 and 5, engine must be running for compressor to operate.

RHA0941

GI
MA
EM
LC
EC
FE
CL
MT
AT
AX
SU
BR
ST
RS
BT
HA
SC
EL
IDX

Self-diagnosis (Cont'd)

FUNCTION CONFIRMATION PROCEDURE (WITH NAVIGATION SYSTEM)

NFHA0176S08

1	SET IN SELF-DIAGNOSTIC MODE
1. Turn ignition switch ON. 2. Set in self-diagnostic mode as follows. Within 10 seconds after starting engine (ignition switch is turned "ON".), press OFF switch for at least 5 seconds.	
▶	GO TO 2.

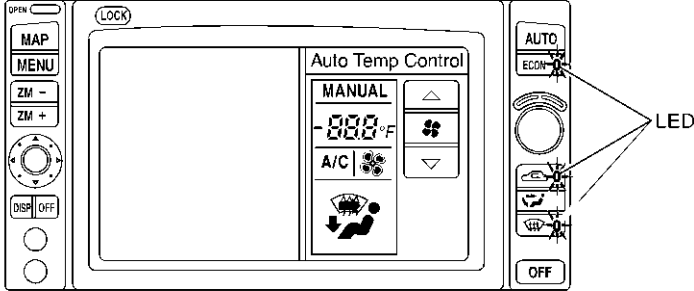
2	STEP 1 - ALL LEDs AND DISPLAY SCREEN ARE CHECKED
When switch's LED and display are functioning properly in STEP-1, LED and display will come on.	
	
RHA095I	
OK or NG	
OK	▶ GO TO 3.
NG	▶ Malfunctioning OFF switch, LED or fluorescent display tube. Go to "Main Power Supply and Ground Circuit Check", HA-72.

3	VERIFY ADVANCE TO SELF-DIAGNOSIS STEP 2
1. Turn temperature dial clockwise. 2. Does advance to self-diagnosis STEP 2?	
Yes or No	
Yes	▶ GO TO 4.
No	▶ Malfunctioning temperature dial. Check Display & NAVI control unit.

4	VERIFY RETURN TO SELF-DIAGNOSIS STEP 1
1. Turn temperature dial counterclockwise. 2. Does return to self-diagnosis STEP 1?	
Yes or No	
Yes	▶ GO TO 5.
No	▶ Malfunctioning temperature dial. Check Display & NAVI control unit.

TROUBLE DIAGNOSES

AUTO

Self-diagnosis (Cont'd)

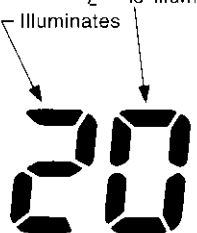
5	STEP 2 - SENSOR CIRCUITS ARE CHECKED FOR OPEN OR SHORT CIRCUIT	
<p>Turn temperature dial clockwise. Does code No. 20 appear on the display?</p>		
<p>Display (when all sensors are in good order)</p> <p>illuminates 25 seconds after "2" is illuminated.</p> 		
RHA970DB		
Yes or No		
Yes	▶	GO TO 6.
No	▶	GO TO 14.

GI
MA
EM
LC
EC
FE
CL
MT

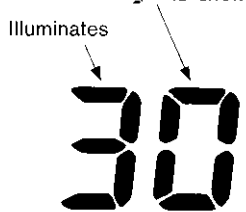
6	STEP 3 - MODE DOOR AND INTAKE DOOR POSITIONS ARE CHECKED	
<p>Turn temperature dial clockwise. Does code No. 30 appear on the display?</p>		
<p>Display (when all doors are in good order)</p> <p>illuminates 50 seconds after "3" is shown on display.</p> 		
RHA869DD		
Yes or No		
Yes	▶	GO TO 7.
No	▶	GO TO 15.

AT
AX
SU
BR
ST
RS
BT

HA

SC
EL
IDX

Self-diagnosis (Cont'd)

7 STEP 4 - OPERATION OF EACH ACTUATOR IS CHECKED

Turn temperature dial clockwise.

Engine running.



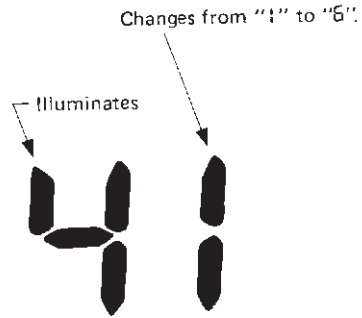











Press DEF switch, code No. of each actuator test is indicated on the display.



RHA495A





GO TO 8.

8	CHECK ACTUATORS																																																		
<p>Confirm operation of system components according to the following charts. Checks must be made visually, by listening to any noise, or by touching air outlets with your hand, etc. for improper operation.</p>																																																			
<table border="1" style="width: 100%; border-collapse: collapse;"> <thead> <tr> <th style="width: 15%;">Code No.</th> <th style="width: 10%;">41</th> <th style="width: 10%;">42</th> <th style="width: 10%;">43</th> <th style="width: 10%;">44</th> <th style="width: 10%;">45</th> <th style="width: 10%;">46</th> </tr> </thead> <tbody> <tr> <td>Actuator</td> <td></td> <td></td> <td></td> <td></td> <td></td> <td></td> </tr> <tr> <td>Mode door</td> <td>VENT</td> <td>B/L</td> <td>B/L</td> <td>FOOT</td> <td>D/F</td> <td>DEF</td> </tr> <tr> <td>Intake door</td> <td>REC</td> <td>REC</td> <td>20% FRE</td> <td>FRE</td> <td>FRE</td> <td>FRE</td> </tr> <tr> <td>Air mix door</td> <td>Full Cold</td> <td>Full Cold</td> <td>Full Hot</td> <td>Full Hot</td> <td>Full Hot</td> <td>Full Hot</td> </tr> <tr> <td>Blower motor</td> <td>4 - 5 V</td> <td>9 - 11 V</td> <td>7 - 9 V</td> <td>7 - 9 V</td> <td>7 - 9 V</td> <td>10 - 12 V</td> </tr> <tr> <td>Compressor</td> <td>ON</td> <td>ON</td> <td>OFF</td> <td>OFF</td> <td>ON</td> <td>ON</td> </tr> </tbody> </table>			Code No.	41	42	43	44	45	46	Actuator							Mode door	VENT	B/L	B/L	FOOT	D/F	DEF	Intake door	REC	REC	20% FRE	FRE	FRE	FRE	Air mix door	Full Cold	Full Cold	Full Hot	Full Hot	Full Hot	Full Hot	Blower motor	4 - 5 V	9 - 11 V	7 - 9 V	7 - 9 V	7 - 9 V	10 - 12 V	Compressor	ON	ON	OFF	OFF	ON	ON
Code No.	41	42	43	44	45	46																																													
Actuator																																																			
Mode door	VENT	B/L	B/L	FOOT	D/F	DEF																																													
Intake door	REC	REC	20% FRE	FRE	FRE	FRE																																													
Air mix door	Full Cold	Full Cold	Full Hot	Full Hot	Full Hot	Full Hot																																													
Blower motor	4 - 5 V	9 - 11 V	7 - 9 V	7 - 9 V	7 - 9 V	10 - 12 V																																													
Compressor	ON	ON	OFF	OFF	ON	ON																																													
<p>Operating condition of each actuator cannot be checked by indicators.</p>																																																			
<p>Discharge air flow</p> <table border="1" style="width: 100%; border-collapse: collapse;"> <thead> <tr> <th rowspan="2" style="width: 25%;">Mode switch</th> <th colspan="3" style="width: 75%;">Air outlet/distribution</th> </tr> <tr> <th style="width: 25%;">Face</th> <th style="width: 25%;">Foot</th> <th style="width: 25%;">Defroster</th> </tr> </thead> <tbody> <tr> <td style="text-align: center;"></td> <td style="text-align: center;">100%</td> <td style="text-align: center;">—</td> <td style="text-align: center;">—</td> </tr> <tr> <td style="text-align: center;"></td> <td style="text-align: center;">60%</td> <td style="text-align: center;">40%</td> <td style="text-align: center;">—</td> </tr> <tr> <td style="text-align: center;"></td> <td style="text-align: center;">—</td> <td style="text-align: center;">80%</td> <td style="text-align: center;">20%</td> </tr> <tr> <td style="text-align: center;"></td> <td style="text-align: center;">—</td> <td style="text-align: center;">60%</td> <td style="text-align: center;">40%</td> </tr> <tr> <td style="text-align: center;"></td> <td style="text-align: center;">—</td> <td style="text-align: center;">—</td> <td style="text-align: center;">100%</td> </tr> </tbody> </table>			Mode switch	Air outlet/distribution			Face	Foot	Defroster		100%	—	—		60%	40%	—		—	80%	20%		—	60%	40%		—	—	100%																						
Mode switch	Air outlet/distribution																																																		
	Face	Foot	Defroster																																																
	100%	—	—																																																
	60%	40%	—																																																
	—	80%	20%																																																
	—	60%	40%																																																
	—	—	100%																																																
<p>OK or NG</p>																																																			
OK	▶	GO TO 9.																																																	
NG	▶	<ul style="list-style-type: none"> ● Air outlet does not change. Go to "Mode Door Motor" (HA-75). ● Intake door does not change. Go to "Intake Door Motor" (HA-87). ● Discharge air temperature does not change. Go to "Air Mix Door Motor" (HA-83). ● Blower motor operation is malfunctioning. Go to "Blower Motor" (HA-91). ● Magnet clutch does not engage. Go to "Magnet Clutch" (HA-101). 																																																	

GI
 MA
 EM
 LC
 EC
 FE
 CL
 MT
 AT
 AX
 SU
 BR
 ST
 RS
 BT
 HA
 SC
 EL
 IDX

Self-diagnosis (Cont'd)

9	STEP 5 - TEMPERATURE OF EACH SENSOR IS CHECKED
<p>Turn temperature dial clockwise. Code No. 51 appears on the display.</p> <p style="text-align: center;">"51" appears on display.</p> <div style="text-align: center;">  </div> <p style="text-align: right;">RHA359H</p>	
▶	GO TO 10.

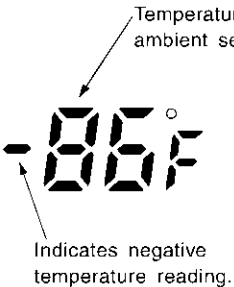
10	CHECK AMBIENT SENSOR
<p>Press  (DEF) switch one time, temperature detected by ambient sensor is indicated on the display. ECON shown in display indicates negative temperature reading.</p> <p>NOTE: If temperature shown on display greatly differs from actual temperature, check sensor circuit first, then inspect sensor.</p> <div style="text-align: center;">  </div> <p style="text-align: right;">RHA861H</p> <p style="text-align: center;">OK or NG</p>	
OK	▶ GO TO 11.
NG	▶ Go to Ambient Sensor Circuit (HA-124).

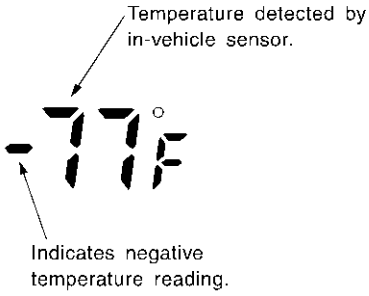
11	CHECK IN-VEHICLE SENSOR	
<p>Press (DEF) switch the second time, temperature detected by in-vehicle sensor is indicated on the display screen. ECON shown in display indicates negative temperature reading.</p> <p>NOTE: If temperature shown on display greatly differs from actual temperature, check sensor circuit first, then inspect sensor.</p> <div style="text-align: center;">  </div> <p style="text-align: right;">RHA862H</p> <p style="text-align: center;">OK or NG</p>		
OK	▶	GO TO 12.
NG	▶	Go to In-vehicle Sensor Circuit (HA-127).

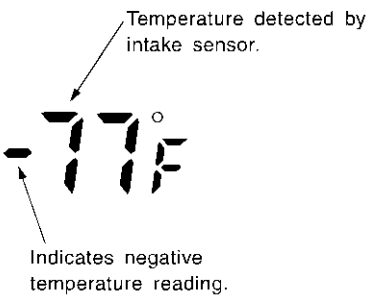
12	CHECK INTAKE SENSOR	
<p>Press (DEF) switch the third time, temperature detected by intake sensor is indicated on the display.</p> <p>NOTE: If temperature shown on display greatly differs from actual temperature, check sensor circuit first, then inspect sensor.</p> <div style="text-align: center;">  </div> <p style="text-align: right;">RHA862HA</p> <p style="text-align: center;">OK or NG</p>		
OK	▶	GO TO 13.
NG	▶	Go to Intake Sensor Circuit (HA-134).

GI
 MA
 EM
 LC
 EC
 FE
 CL
 MT
 AT
 AX
 SU
 BR
 ST
 RS
 BT
 HA
 SC
 EL
 IDX

TROUBLE DIAGNOSES

AUTO

Self-diagnosis (Cont'd)

13	DETECTS MULTIPLEX COMMUNICATION ERROR									
Press REC switch. Does code No. 52 appears on the display										
<table border="1" style="margin: auto; border-collapse: collapse;"> <thead> <tr> <th style="width: 30%;">Display</th> <th>Signal direction</th> </tr> </thead> <tbody> <tr> <td style="text-align: center;">52</td> <td>In good order</td> </tr> <tr> <td style="text-align: center;">52 </td> <td>Display & NAVI control unit → Auto amp.</td> </tr> <tr> <td style="text-align: center;">52 </td> <td>Auto amp. → Display & NAVI control unit</td> </tr> </tbody> </table>			Display	Signal direction	52	In good order	52	Display & NAVI control unit → Auto amp.	52	Auto amp. → Display & NAVI control unit
Display	Signal direction									
52	In good order									
52	Display & NAVI control unit → Auto amp.									
52	Auto amp. → Display & NAVI control unit									
MTBL0509										
Yes or No										
Yes	▶	INSPECTION END								
No	▶	1. Go to "Multiplex Communication Circuit", HA-137. 2. Go to "OPERATIONAL CHECK", HA-67. Confirm that A/C system is in good order.								

14 CHECK MALFUNCTIONING SENSOR

NOTE:

- A blinking mark (-) preceding the Code No. indicates a short circuit.
- If 2 or more items are malfunctioning, the corresponding codes will alternately blink twice.
- A circuit will be detected as open or shorted and its code No. will be displayed when input signals correspond with conditions in the following chart.

Code No.	Sensor	Open circuit	Short circuit	Reference page
21	Ambient sensor	Less than -43.8°C (-47°F)	Greater than 100°C (212°F)	*3
-21				
22	In-vehicle sensor	Less than -43.8°C (-47°F)	Greater than 100°C (212°F)	*4
-22				
24	Intake sensor	Less than -43.8°C (-47°F)	Greater than 100°C (212°F)	*5
-24				
25	Sunload sensor*2	Less than 0.228 mA	Greater than 0.98 mA	*6
-25				
26	PBR*1	Greater than 95%	Less than 5%	*7
-26				

*1: "95%" and "5%" refer to percentage with respect to stroke of air mix door. (Full cold: 0%, Full hot: 100%)

*2: **Conduct self-diagnosis STEP 2 under sunshine.**

When conducting indoors, direct light (more than 60W) at sunload sensor.

*3: HA-124, *4: HA-127, *5: HA-134, *6: HA-130, *7: HA-136

Display (when sensor malfunctions)

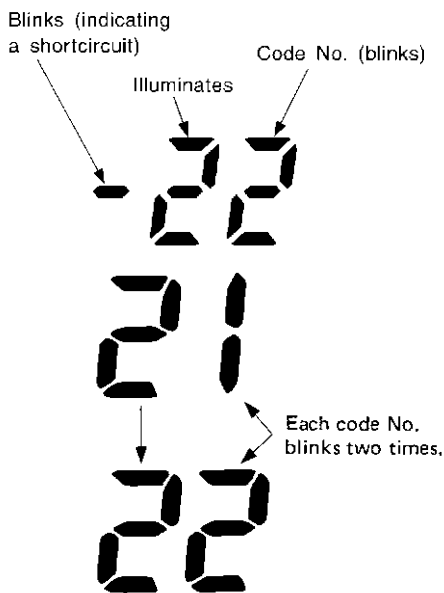

MTBL1185

RHA455G

RHA501A



INSPECTION END

GI
 MA
 EM
 LC
 EC
 FE
 CL
 MT
 AT
 AX
 SU
 BR
 ST
 RS
 BT
HA
 SC
 EL
 IDX

15	CHECK MALFUNCTIONING DOOR MOTOR POSITION SWITCH
<p>30- Mode door and intake door position switches are in working order. Continue ot next step.</p> <p>31- Mode door circuit / switch in vent position switch is malfunctioning.</p> <p>32- Mode door circuit / switch in B/L position switch is malfunctioning.</p> <p>34- Mode door circuit / switch in Foot position switch is malfunctioning.</p> <p>35- Mode door circuit / switch in Foot Def. position switch is malfunctioning.</p> <p>36- Mode door circuit / switch in Def. position switch is malfunctioning.</p> <p>37- Intake door mode circuit / switch in Fresh Air position is malfunctioning.</p> <p>38- Intake door mode circuit / switch in 20% Fresh Air position is malfunctioning.</p> <p>39- Intake door mode circuit / switch in Recirculation Air position is malfunctioning.</p> <p>NOTE:</p> <ul style="list-style-type: none"> ● If 2 or more items are malfunctioning, the corresponding codes will alternately blink twice. ● If the Mode Door Motor harness is disconnected, repeated display pattern of 31 → 32 → 34 → 35 → 36 will occur. ● If Intake Door Motor harness is disconnected, repeated display pattern of 37 → 38 → 39 will occur. ● If any Mode Door Motor Position Switch is malfunctioning, the Mode Door Motor will also malfunction. <div style="text-align: center; margin-top: 20px;"> <p>Display (when a door is out of order)</p> <p style="margin-left: 100px;">Illuminates</p> <p style="margin-left: 150px;">Code No. (blinks)</p> <p style="margin-left: 100px;">Each code No. blinks two times.</p> </div> <div style="display: flex; justify-content: space-between; margin-top: 20px;"> RHA168DA RHA498A </div>	
▶	INSPECTION END

AUXILIARY MECHANISM: TEMPERATURE SETTING TRIMMER (WITH NAVIGATION SYSTEM)

Unconfirmed Incidents

The trimmer compensates for differences in range of $\pm 3^{\circ}\text{C}$ ($\pm 6^{\circ}\text{F}$) between temperature setting (displayed digitally) and temperature felt by driver.

Operating procedures for this trimmer are as follows:

- Begin Self-diagnosis STEP 5 mode.
- Press  (fan) UP switch to set system in auxiliary mode.
- Display shows "61" in auxiliary mechanism. It takes approximately 3 seconds.
- Turn the temperature dial clockwise or counterclockwise: Temperature will change at a rate of 0.5°C (1°F).

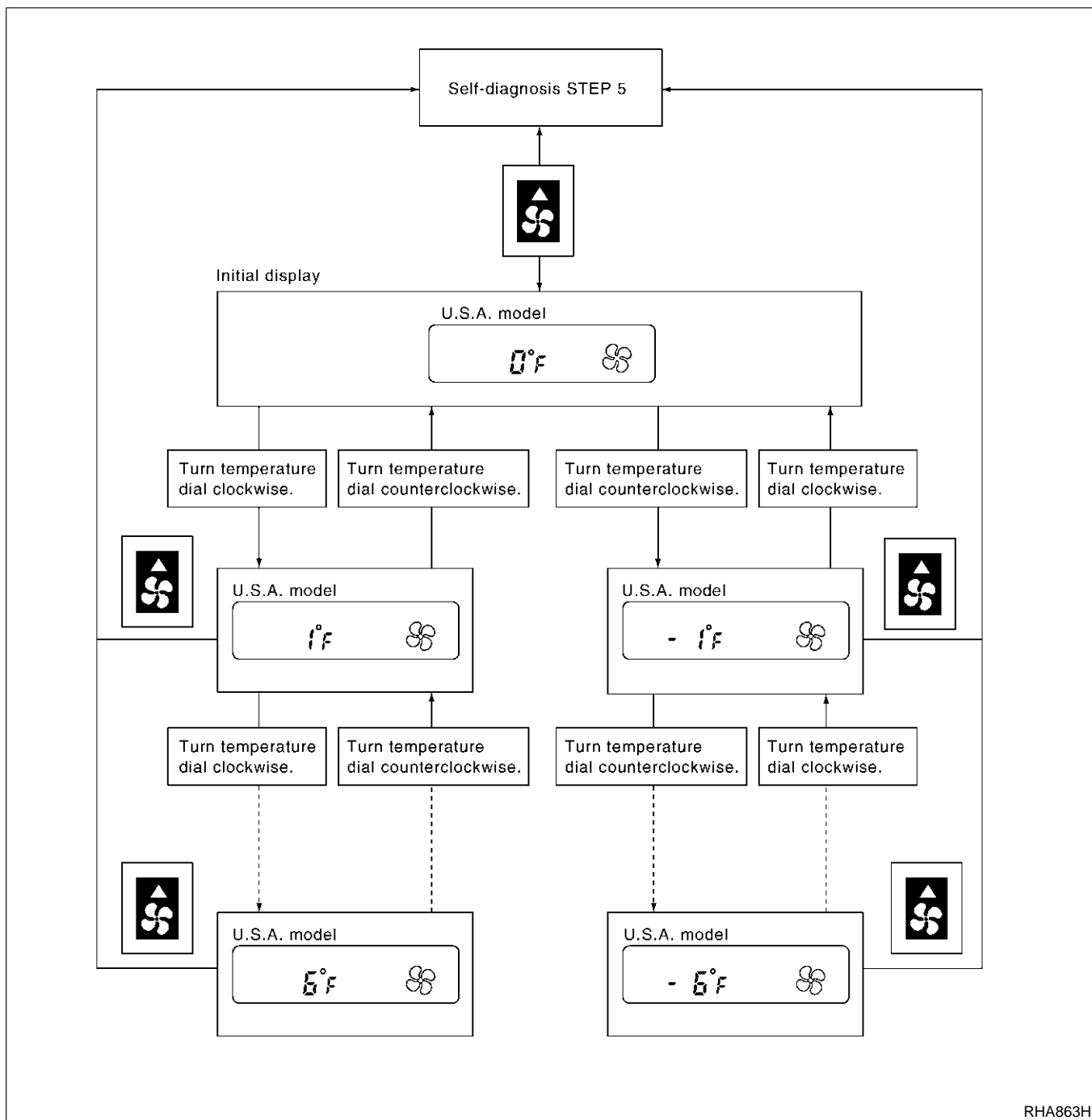

RHA863H

When battery cable is disconnected, trimmer operation is canceled. Temperature set becomes that of initial condition, i.e. 0°C (0°F).

GI
 MA
 EM
 LC
 EC
 FE
 CL
 MT
 AT
 AX
 SU
 BR
 ST
 RS
 BT
HA
 SC
 EL
 IDX

How to Perform Trouble Diagnoses for Quick and Accurate Repair

=NFHA0177

NFHA0177S01

WORK FLOW

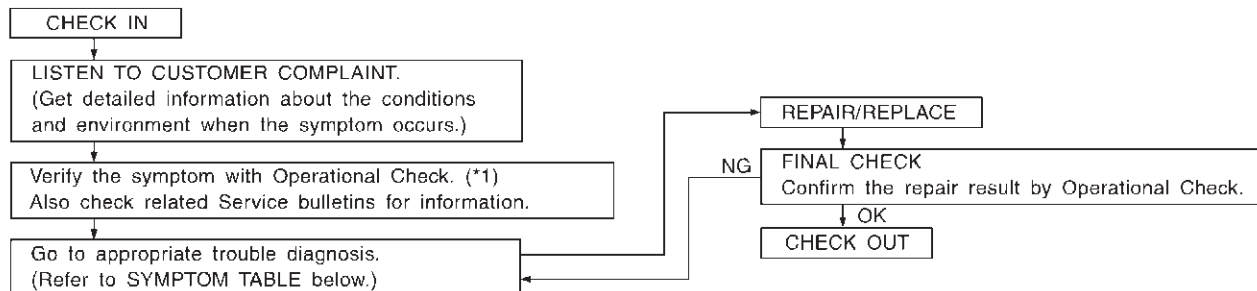

SHA900E

*1: Operational Check (HA-65)

SYMPTOM TABLE

NFHA0177S02

Symptom	Reference Page	
● A/C system does not come on.	● Go to Trouble Diagnosis Procedure for A/C system.	HA-70
● Air outlet does not change. ● Mode door motor does not operate normally.	● Go to Trouble Diagnosis Procedure for Mode Door Motor. (LAN)	HA-75
● Discharge air temperature does not change. ● Air mix door motor does not operate normally.	● Go to Trouble Diagnosis Procedure for Air Mix Door Motor. (LAN)	HA-83
● Intake door does not change. ● Intake door motor does not operate normally.	● Go to Trouble Diagnosis Procedure for Intake Door Motor. (LAN)	HA-87
● Blower motor operation is malfunctioning. ● Blower motor operation is malfunctioning under out of starting fan speed control.	● Go to Trouble Diagnosis Procedure for Blower Motor.	HA-91
● Magnet clutch does not engage.	● Go to Trouble Diagnosis Procedure for Magnet Clutch.	HA-101
● Insufficient cooling.	● Go to Trouble Diagnosis Procedure for Insufficient Cooling.	HA-108
● Insufficient heating.	● Go to Trouble Diagnosis Procedure for Insufficient Heating.	HA-117
● Noise.	● Go to Trouble Diagnosis Procedure for Noise.	HA-119
● Self-diagnosis can not be performed.	● Go to Trouble Diagnosis Procedure for Self-diagnosis.	HA-121
● Memory function does not operate.	● Go to Trouble Diagnosis Procedure for Memory Function.	HA-122
● ECON mode does not operate.	● Go to Trouble Diagnosis Procedure for ECON (ECONOMY) — mode.	HA-123
● A/C system cannot be controlled (With navigation system).	● Go to Trouble Diagnosis Procedure for Multiplex Communication Circuit.	HA-137

Operational Check

The purpose of the operational check is to confirm that the system operates properly.

CONDITIONS:

- Engine running and at normal operating temperature.

NFHA0178

GI

NFHA0178S01

MA

EM

LC

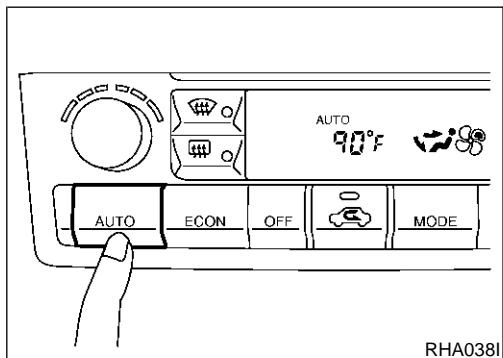

PROCEDURE: (WITHOUT NAVIGATION SYSTEM)

NFHA0178S02

1. Check Memory Function

NFHA0178S02

NFHA0178S0201

EC

FE

CL

MT

1. Set the temperature 90°F or 32°C.
2. Press OFF switch.
3. Turn the ignition off.
4. Turn the ignition on.
5. Press the AUTO switch.
6. Confirm that the set temperature remains at previous temperature.
7. Press OFF switch.

If NG, go to trouble diagnosis procedure for memory function (HA-122).

If OK, continue with next check.

AT

AX

SU

BR

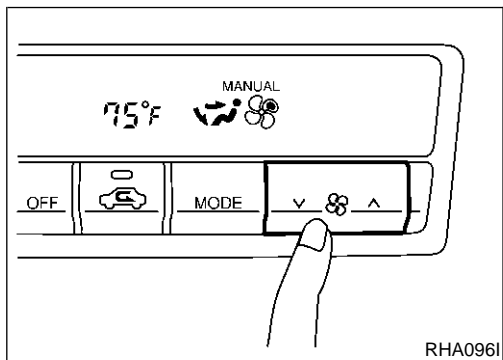

2. Check Blower

NFHA0178S0202

ST

1. Press fan switch (up side) one time. Blower should operate on low speed. The fan symbol should have one blade lit.
2. Press fan switch (up side) one more time, and continue checking blower speed and fan symbol until all speeds are checked.
3. Leave blower on MAX speed.

If NG, go to trouble diagnosis procedure for blower motor (HA-91).
If OK, continue with next check.

RS

BT

HA

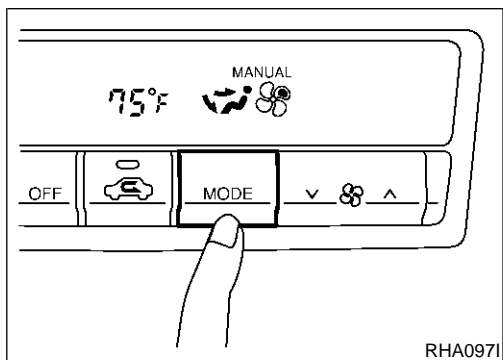

3. Check Discharge Air

NFHA0178S0203

SC

1. Press mode switch four times and DEF button.
2. Each position indicator should change shape.

EL

IDX

Operational Check (Cont'd)

Discharge air flow

Mode control knob	Air outlet/distribution		
	Face	Foot	Defroster
	100%	-	-
	60%	40%	-
	-	80%	20%
	-	60%	40%
	-	-	100%

RHA654F

3. Confirm that discharge air comes out according to the air distribution table at left.
Refer to "Discharge Air Flow" (HA-26).

NOTE:

Confirm that the compressor clutch is engaged (visual inspection) and intake door position is at FRESH when the DEF is selected.

Intake door position is checked in the next step.

If NG, go to trouble diagnosis procedure for mode door motor (HA-75).

If OK, continue with next check.

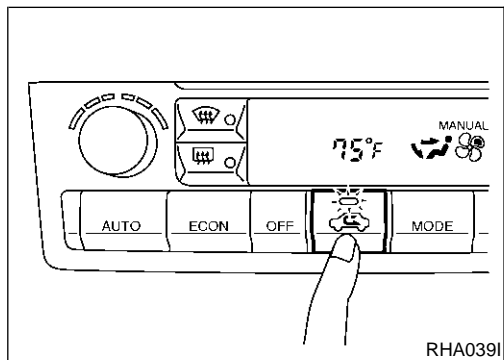

4. Check Recirculation

NFHA0178S0204

1. Press REC switch.
Recirculation indicator should illuminate.
2. Listen for intake door position change (you should hear blower sound change slightly).

If NG, go to trouble diagnosis procedure for intake door (HA-87).

If OK, continue with next check.

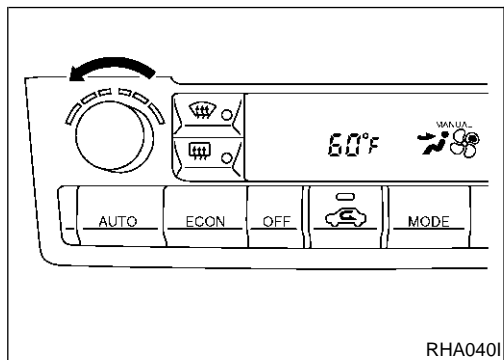

5. Check Temperature Decrease

NFHA0178S0205

1. Turn the temperature dial counterclockwise until 18°C (60°F) is displayed.
2. Check for cold air at discharge air outlets.

If NG, go to trouble diagnosis procedure for insufficient cooling (HA-108).

If OK, continue with next check.

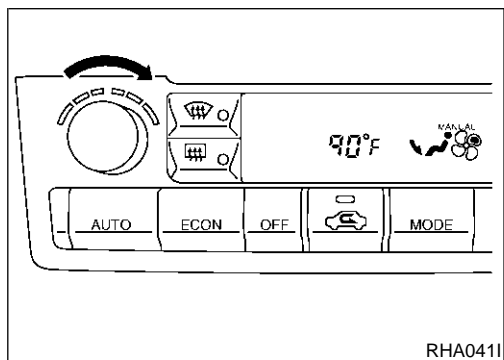

6. Check Temperature Increase

NFHA0178S0206

1. Turn the temperature dial clockwise until 32°C (90°F) is displayed.
2. Check for hot air at discharge air outlets.

If NG, go to trouble diagnosis procedure for insufficient heating (HA-117).

If OK, continue with next check.

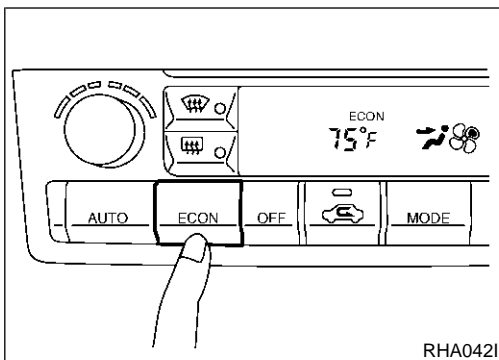

7. Check ECON (Economy) Mode

NFHA0178S0207

1. Set the temperature 75°F or 25°C.
2. Press ECON switch.
3. Display should indicate ECON (no AUTO).
Confirm that the compressor clutch is not engaged (visual inspection).
(Discharge air and blower speed will depend on ambient, in-vehicle and set temperatures.)

If NG, go to trouble diagnosis procedure for ECON (Economy) mode (HA-123).

If OK, continue with next check.

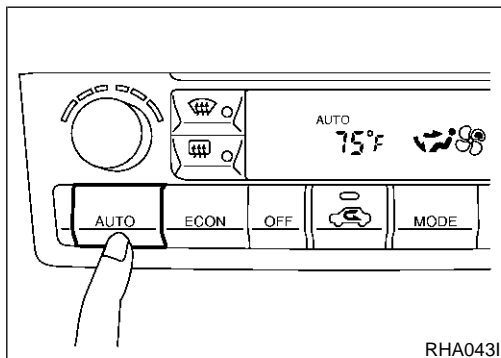

8. Check AUTO Mode

NFHA0178S0208

1. Press AUTO switch.
2. Display should indicate AUTO (no ECON).
Confirm that the compressor clutch engages (audio or visual inspection).
(Discharge air and blower speed will depend on ambient, in-vehicle and set temperatures.)

If NG, go to trouble diagnosis procedure for A/C system (HA-70), then if necessary, trouble diagnosis procedure for magnet clutch (HA-101).

If all operational check are OK (symptom can not be duplicated), go to "Incident Simulation Tests" (GI-25) and perform tests as outlined to simulate driving conditions environment. If symptom appears, refer to "Symptom Table" (HA-64) and perform applicable trouble diagnosis procedures.

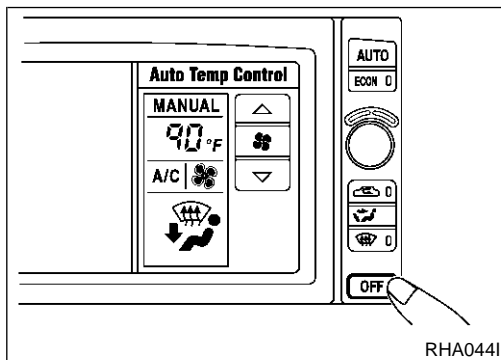

PROCEDURE: (WITH NAVIGATION SYSTEM)

NFHA0178S03

1. Check Memory Function

NFHA0178S0301

1. Set the temperature 90°F or 32°C.
2. Press OFF switch.
3. Turn the ignition off.
4. Turn the ignition on.
5. Press the AUTO switch.
6. Confirm that the set temperature remains at previous temperature.
7. Press OFF switch.

If NG, go to trouble diagnosis procedure for memory function (HA-122).

If OK, continue with next check.

GI

MA

EM

LC

EC

FE

CL

MT

AT

AX

SU

BR

ST

RS

BT

HA

SC

EL

IDX

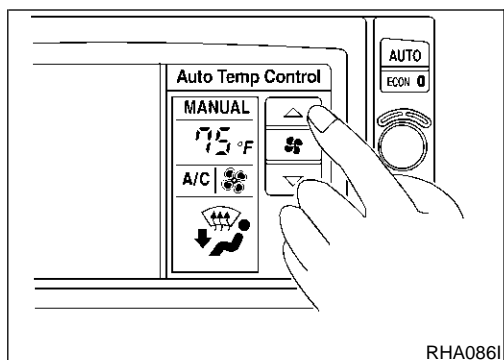

2. Check Blower

NFHA0178S0302

1. Press fan switch (up side) one time.
Blower should operate on low speed.
The fan symbol should have one blade lit .
2. Press fan switch (up side) one more time, and continue checking blower speed and fan symbol until all speeds are checked.
3. Leave blower on MAX speed .

If NG, go to trouble diagnosis procedure for blower motor (HA-91).
If OK, continue with next check.

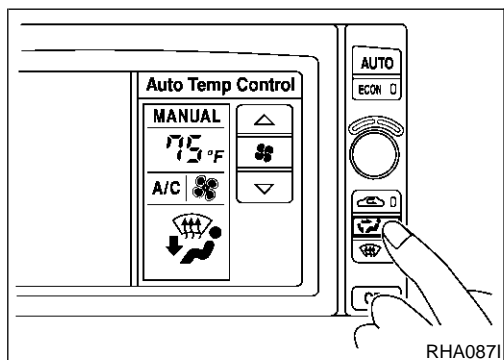

3. Check Discharge Air

NFHA0178S0303

1. Press mode switch four times and DEF button.
2. Each position indicator should change shape.

3. Confirm that discharge air comes out according to the air distribution table at left.
Refer to "Discharge Air Flow" (HA-26).

NOTE:

Confirm that the compressor clutch is engaged (visual inspection) and intake door position is at FRESH when the DEF is selected.

Intake door position is checked in the next step.

If NG, go to trouble diagnosis procedure for mode door motor (HA-75).

If OK, continue with next check.

Discharge air flow

Mode control knob	Air outlet/distribution		
	Face	Foot	Defroster
	100%	—	—
	60%	40%	—
	—	80%	20%
	—	60%	40%
	—	—	100%

RHA654F

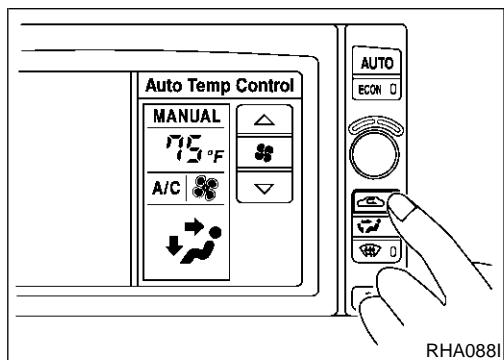

4. Check Recirculation

NFHA0178S0304

1. Press REC switch.
Recirculation indicator should illuminate.
2. Listen for intake door position change (you should hear blower sound change slightly).

If NG, go to trouble diagnosis procedure for intake door (HA-87).
If OK, continue with next check.

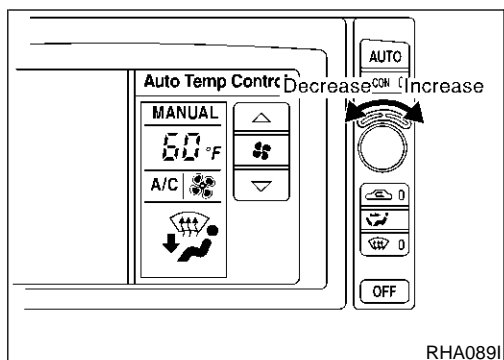

5. Check Temperature Decrease

1. Turn the temperature dial counterclockwise until 18°C (60°F) is displayed. NFHA0178S0305
 2. Check for cold air at discharge air outlets.
- If NG, go to trouble diagnosis procedure for insufficient cooling (HA-108).
If OK, continue with next check.

GI

MA

EM

LC

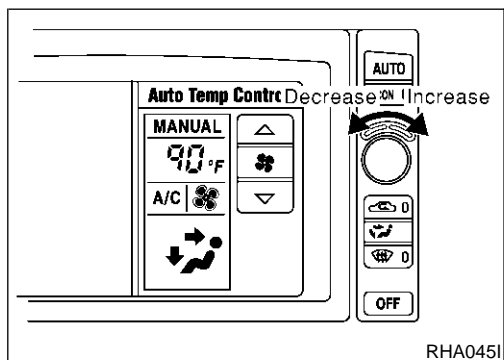

6. Check Temperature Increase

1. Turn the temperature dial clockwise until 32°C (90°F) is displayed. NFHA0178S0306
 2. Check for hot air at discharge air outlets.
- If NG, go to trouble diagnosis procedure for insufficient heating (HA-117).
If OK, continue with next check.

EC

FE

CL

MT

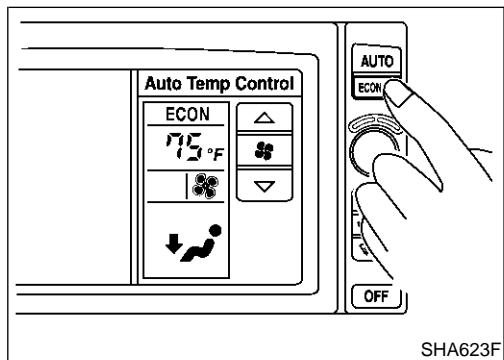

7. Check ECON (Economy) Mode

1. Set the temperature 75°F or 25°C. NFHA0178S0307
2. Press ECON switch.
3. Display should indicate ECON (no AUTO).
Confirm that the compressor clutch is not engaged (visual inspection).
(Discharge air and blower speed will depend on ambient, in-vehicle and set temperatures.)

AT

AX

SU

If NG, go to trouble diagnosis procedure for ECON (Economy) mode (HA-123).

BR

If OK, continue with next check.

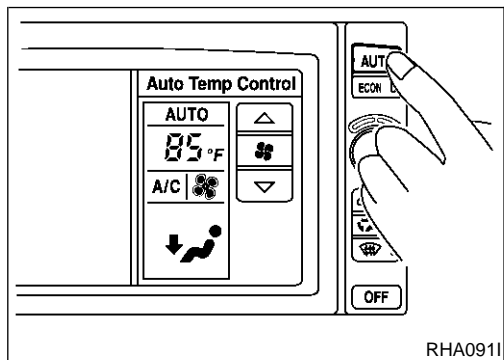

8. Check AUTO Mode

1. Press AUTO switch. NFHA0178S0308
2. Display should indicate AUTO (no ECON).
Confirm that the compressor clutch engages (audio or visual inspection).
(Discharge air and blower speed will depend on ambient, in-vehicle and set temperatures.)

ST

RS

BT

If NG, go to trouble diagnosis procedure for A/C system (HA-70), then if necessary, trouble diagnosis procedure for magnet clutch (HA-101).

HA

If all operational check are OK (symptom can not be duplicated), go to "Incident Simulation Tests" (GI-25) and perform tests as outlined to simulate driving conditions environment. If symptom appears, refer to "Symptom Table" (HA-64) and perform applicable trouble diagnosis procedures.

SC

EL

IDX

A/C System

TROUBLE DIAGNOSIS PROCEDURE FOR A/C SYSTEM

=NFHA0179

SYMPTOM:

- A/C system does not come on.

INSPECTION FLOW

1. Confirm symptom by performing the following operational check.

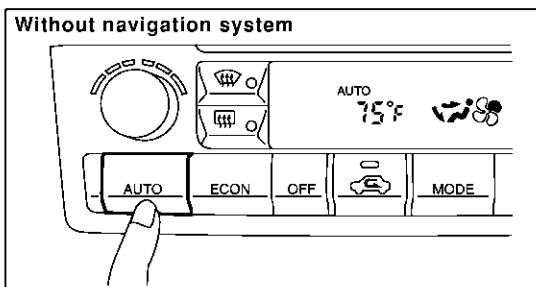

OPERATIONAL CHECK – AUTO mode

- a. Press AUTO switch.
- b. Display should indicate AUTO (not ECON). Confirm that the compressor clutch engages (audio or visual inspection). (Discharge air and blower speed will depend on ambient, in-vehicle and set temperatures.)

**If OK (symptom cannot be duplicated), perform complete operational check (*2).
If NG (symptom is confirmed), continue with STEP-2 following.**

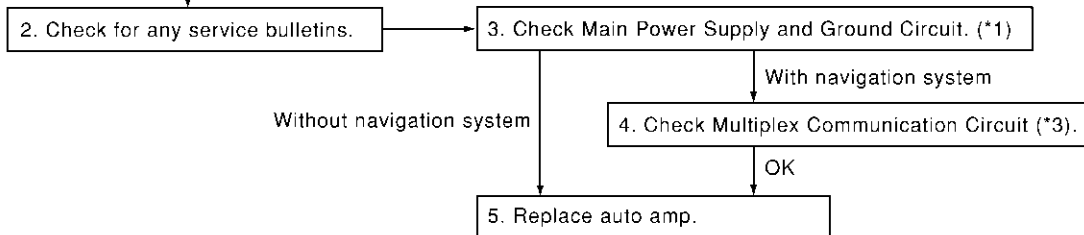
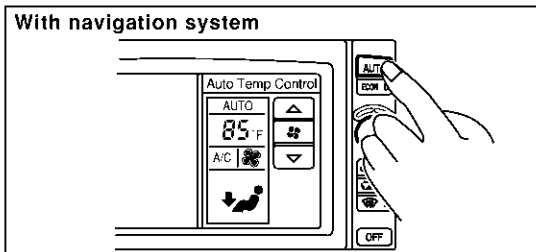

RHA0461

*1: HA-72

*2: HA-65

*3: HA-137

Without navigation system

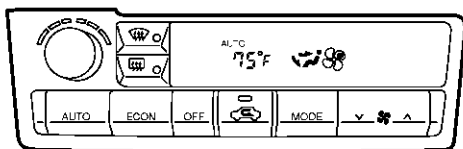

Control amp. (Built into auto amp.)

RHA036I

With navigation system

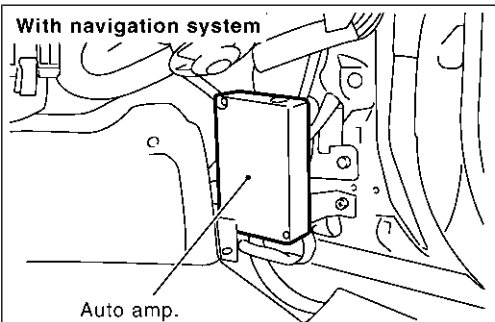

Auto amp.

RHA037I

Without navigation system

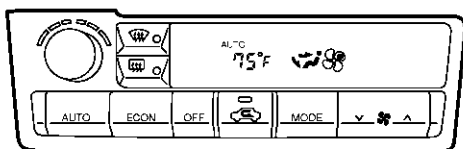

Control amp. (Built into auto amp.)

RHA036I

With navigation system

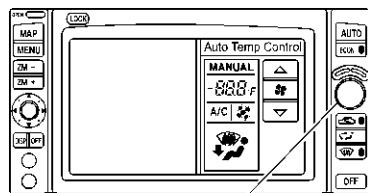

Temperature dial (PTC)

RHA098I

COMPONENT DESCRIPTION

Automatic Amplifier (Auto Amp.)

NFHA0247

NFHA0247S01

The auto amplifier has a built-in microcomputer which processes information sent from various sensors needed for air conditioner operation. The air mix door motor, mode door motor, intake door motor, blower motor and compressor are then controlled.

The auto amplifier is unitized with control mechanisms. Signals from various switches and Potentio Temperature Control (PTC) are directly entered into auto amplifier.

Self-diagnostic functions are also built into auto amplifier to provide quick check of malfunctions in the auto air conditioner system.

GI

MA

EM

LC

EC

FE

CL

MT

Potentio Temperature Control (PTC)

NFHA0247S02

The PTC is built into the A/C auto amp. or Display and NAVI control unit. It can be set at an interval of 0.5°C (1.0°F) in the 18°C (60°F) to 32°C (90°F) temperature range by pushing the temperature button. The set temperature is digitally displayed.

AT

AX

SU

BR

ST

RS

BT

HA

SC

EL

IDX

MAIN POWER SUPPLY AND GROUND CIRCUIT CHECK

=NFHA0180

Power Supply Circuit Check

NFHA0180S03

Check power supply circuit for air conditioner system.
Refer to EL-12, "Wiring Diagram — POWER —".

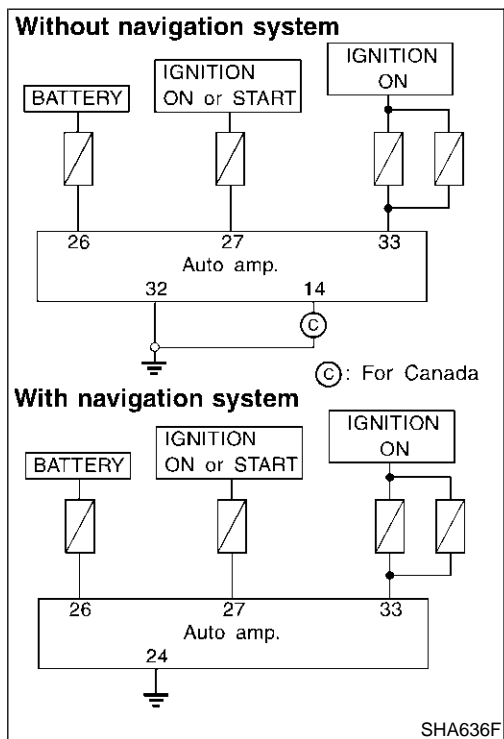

DIAGNOSTIC PROCEDURE

NFHA0181

SYMPTOM:

- A/C system does not come on.

1	CHECK POWER SUPPLY CIRCUIT FOR AUTO AMP.											
Measure voltage across harness connector terminal Nos. 26, 27, 33 and body ground.												
Without navigation system												
<table border="1" style="width: 100%; border-collapse: collapse;"> <thead> <tr> <th colspan="2" style="text-align: center;">Voltmeter terminal</th> <th rowspan="2" style="text-align: center;">Voltage</th> </tr> <tr> <th style="text-align: center;">(+)</th> <th style="text-align: center;">(-)</th> </tr> </thead> <tbody> <tr> <td style="text-align: center;">26</td> <td rowspan="3" style="text-align: center;">Ground</td> <td rowspan="3" style="text-align: center;">Approx. 12V</td> </tr> <tr> <td style="text-align: center;">27</td> </tr> <tr> <td style="text-align: center;">33</td> </tr> </tbody> </table>		Voltmeter terminal		Voltage	(+)	(-)	26	Ground	Approx. 12V	27	33	GI MA EM LC EC FE CL MT
Voltmeter terminal		Voltage										
(+)	(-)											
26	Ground	Approx. 12V										
27												
33												
With navigation system												
<table border="1" style="width: 100%; border-collapse: collapse;"> <thead> <tr> <th colspan="2" style="text-align: center;">Voltmeter terminal</th> <th rowspan="2" style="text-align: center;">Voltage</th> </tr> <tr> <th style="text-align: center;">(+)</th> <th style="text-align: center;">(-)</th> </tr> </thead> <tbody> <tr> <td style="text-align: center;">26</td> <td rowspan="3" style="text-align: center;">Ground</td> <td rowspan="3" style="text-align: center;">Approx. 12V</td> </tr> <tr> <td style="text-align: center;">27</td> </tr> <tr> <td style="text-align: center;">33</td> </tr> </tbody> </table>		Voltmeter terminal		Voltage	(+)	(-)	26	Ground	Approx. 12V	27	33	AT AX SU BR ST RS BT
Voltmeter terminal		Voltage										
(+)	(-)											
26	Ground	Approx. 12V										
27												
33												
SHA637FA												
OK or NG												
OK	▶	GO TO 2.										
NG	▶	Check auto amp. power circuit. <ul style="list-style-type: none"> ● Check 10A fuses [Nos. 12 and 28, located in the fuse block (J/B)] and 15A fuses (Nos. 51 and 52, located in the fuse and fusible link box). ● If fuses are OK, check for open circuit in wiring harness. Repair or replace as necessary. ● If fuses are NG, replace fuse and check wiring harness for short circuit. Repair or replace as necessary. 										

GI
MA
EM
LC
EC
FE
CL
MT
AT
AX
SU
BR
ST
RS
BT
HA
SC
EL
IDX

2 CHECK BODY GROUND CIRCUIT FOR AUTO AMP.

Does continuity exist between auto amp. harness connector terminal Nos. 32, 24 and body ground?

Without navigation system

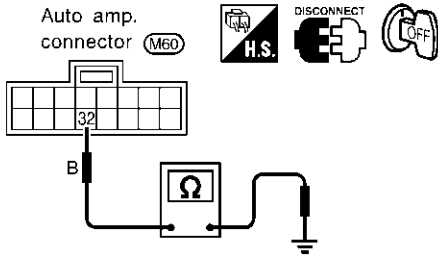

Voltmeter terminal		Continuity
(+)	(-)	
32	Ground	Yes
24		

With navigation system

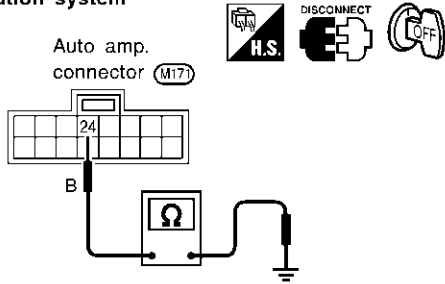

RHA048IA

Yes or No

Yes	▶	Replace auto amp. INSPECTION END
No	▶	Repair or replace harness.

Mode Door Motor

TROUBLE DIAGNOSIS PROCEDURE FOR MODE DOOR MOTOR (LAN)

=NFHA0182

SYMPTOM:

- Air outlet does not change.
- Mode door motor does not operate normally.

Inspection Flow

Without Navigation System

NFHA0182S01

NFHA0182S0101

1. Confirm symptom by performing the following operational check.

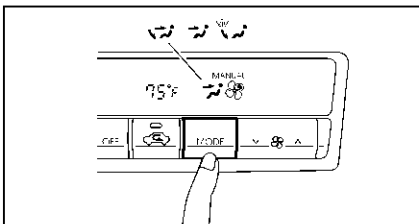

OPERATIONAL CHECK – Discharge air

- a. Press mode switch four times and DEF button.
- b. Each position indicator should change shape.

Discharge air flow

Mode control knob	Air outlet/distribution		
	Face	Foot	Defroster
	100%	-	-
	60%	40%	-
	-	80%	20%
	-	60%	40%
	-	-	100%

c. Confirm that discharge air comes out according to the air distribution table at left.

Refer to “Discharge Air Flow” (*1).

NOTE:

- If **OK** (symptom cannot be duplicated), perform complete operational check (*2).
- If **NG** (symptom is confirmed), continue with **STEP-2** following.
- Confirm that the compressor clutch is engaged (visual inspection) and intake door position is at **FRESH** when **DEF** is selected. Intake door position is checked in the next step.

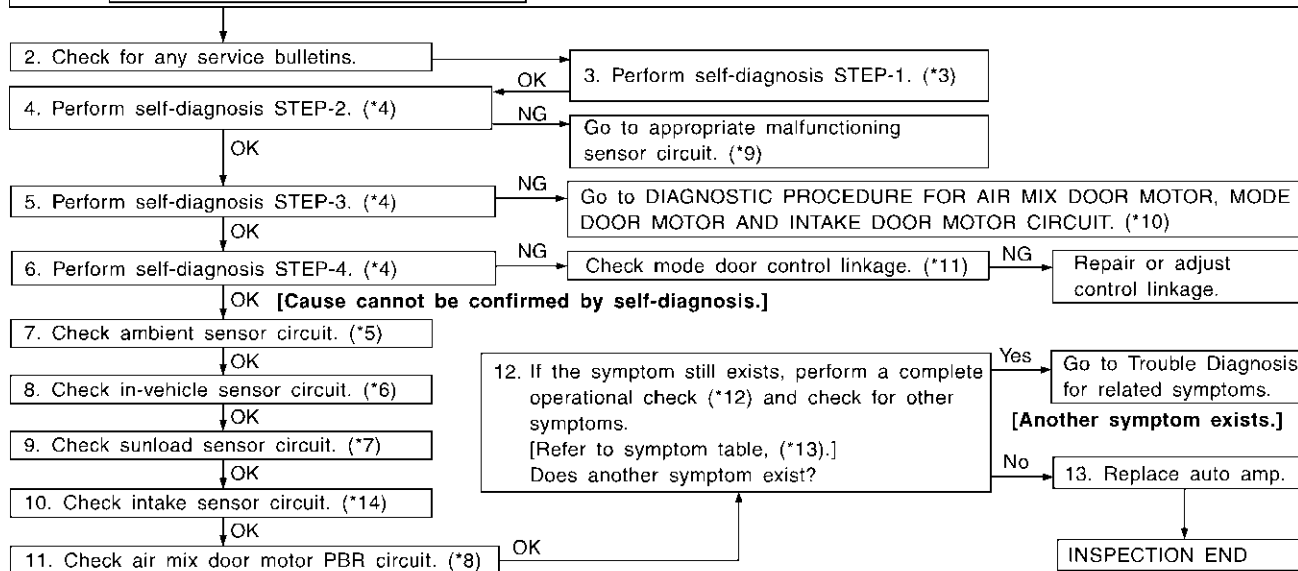

*1: HA-26
 *2: HA-65
 *3: HA-43
 *4: HA-44
 *5: HA-124
 *6: HA-127

*7: HA-130
 *8: HA-136
 *9: FUNCTION CONFIRMATION PROCEDURE (HA-44), see No. 13.
 *10: HA-78

*11: HA-81
 *12: HA-65
 *13: HA-64
 *14: HA-134

GI
MA
EM
LC
EC
FE
CL
MT
AT
AX
SU
BR
ST
RS
BT
HA
SC
EL
IDX

1. Confirm symptom by performing the following operational check.

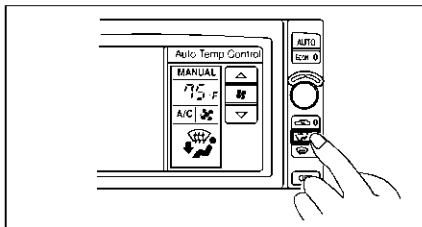

OPERATIONAL CHECK – Discharge air

- a. Press mode switch four times and DEF button.
- b. Each position indicator should change shape.

Discharge air flow

Mode control knob	Air outlet/distribution		
	Face	Foot	Defroster
	100%	-	-
	60%	40%	-
	-	80%	20%
	-	60%	40%
	-	-	100%

c. Confirm that discharge air comes out according to the air distribution table at left.

Refer to "Discharge Air Flow" (*1).

NOTE:

- If OK (symptom cannot be duplicated), perform complete operational check (*2).
- If NG (symptom is confirmed), continue with STEP-2 following.
- Confirm that the compressor clutch is engaged (visual inspection) and intake door position is at FRESH when DEF is selected. Intake door position is checked in the next step.

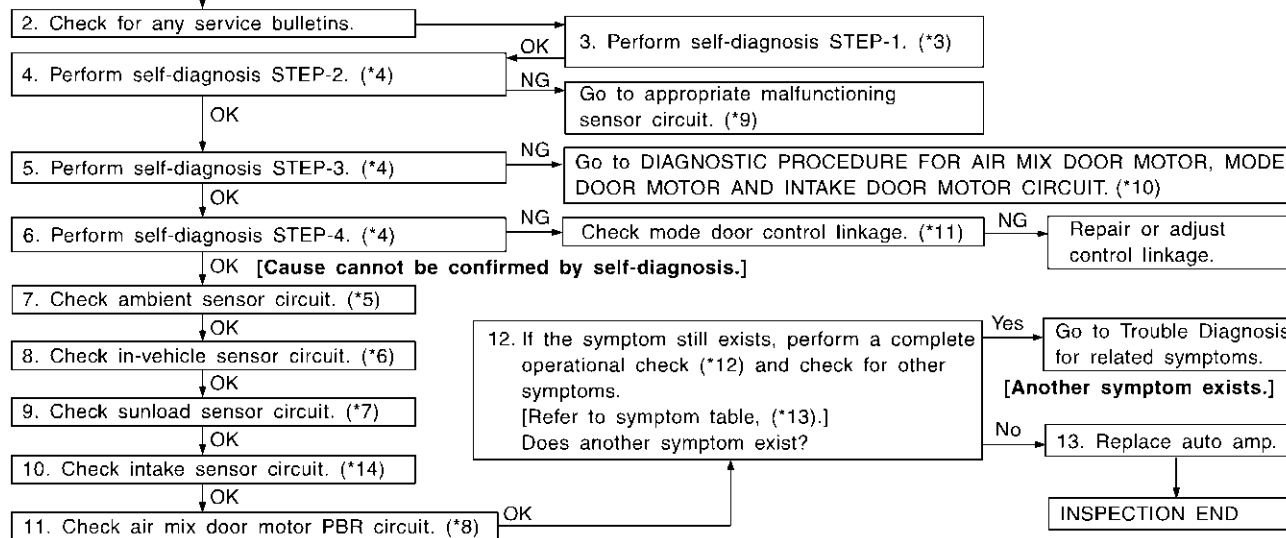

SHA768F

- *1: HA-26
- *2: HA-67
- *3: HA-53
- *4: HA-54
- *5: HA-124
- *6: HA-127

- *7: HA-130
- *8: HA-136
- *9: FUNCTION CONFIRMATION PROCEDURE (HA-54), see No. 14.
- *10: HA-78

- *11: HA-81
- *12: HA-67
- *13: HA-64
- *14: HA-134

SYSTEM DESCRIPTION

Component Parts

Mode door control system components are:

- 1) Auto amp.
- 2) Mode door motor (LCU)
- 3) In-vehicle sensor
- 4) Ambient sensor
- 5) Sunload sensor
- 6) Intake sensor

System Operation

The auto amplifier receives data from each of the sensors. The amplifier sends air mix door, mode door and intake door opening angle data to the air mix door motor LCU, mode door motor LCU and intake door motor LCU.

The air mix door motor, mode door motor and intake door motor read their respective signals according to the address signal. Opening angle indication signals received from the auto amplifier and each of the motor position sensors are compared by the LCUs in each motor with the existing decision and opening angles. Subsequently, HOT/COLD or OPEN/CLOSE or DEFROST/VENT operation is selected. The new selection data is returned to the auto amplifier.

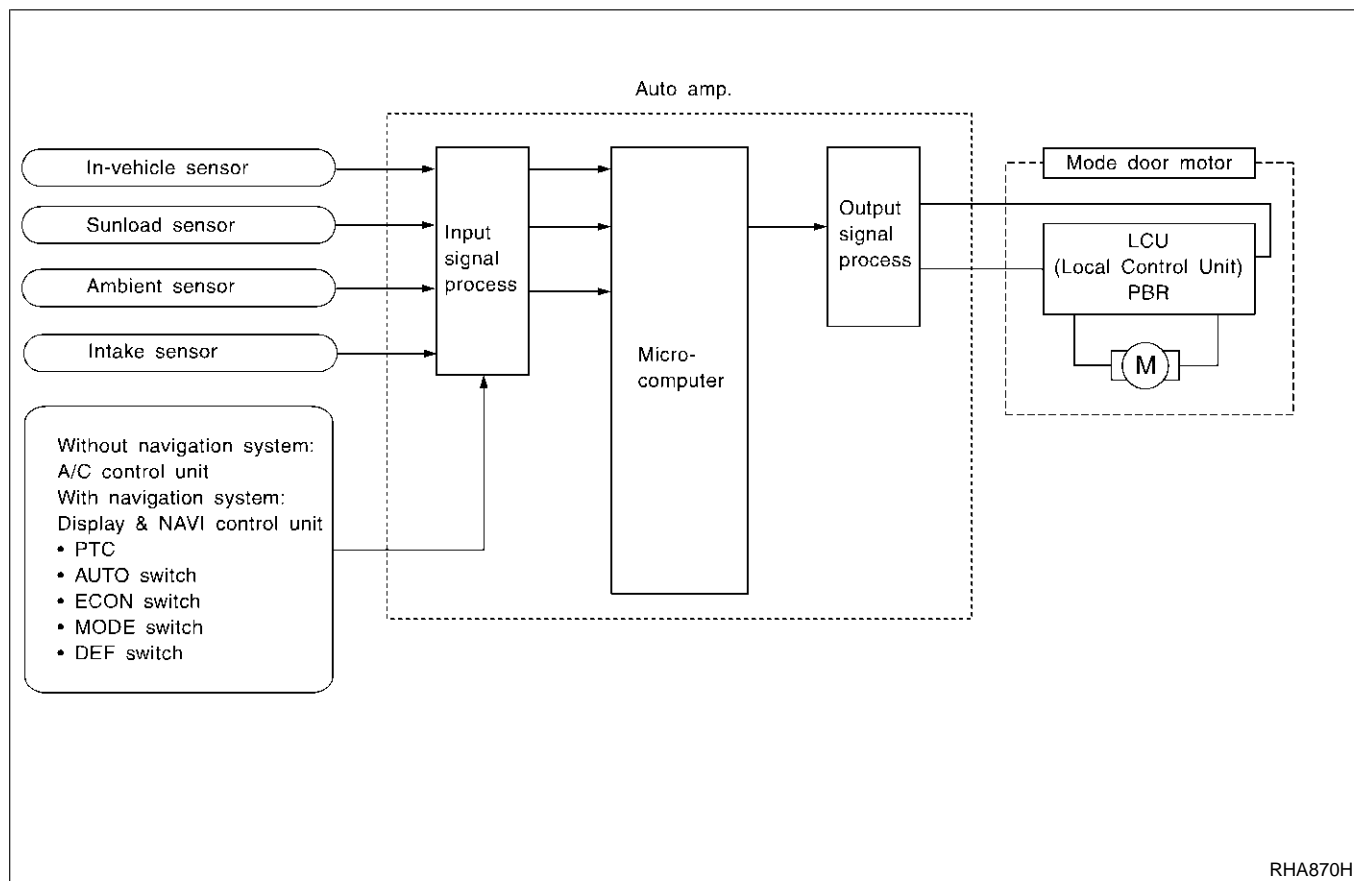

RHA870H

GI
 MA
 EM
 LC
 EC
 FE
 CL
 MT
 AT
 AX
 SU
 BR
 ST
 RS
 BT
HA
 SC
 EL
 IDX

Mode Door Motor (Cont'd)

NFHA0183S03

Mode Door Control Specification

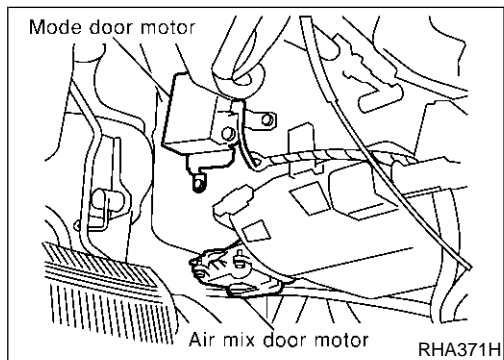
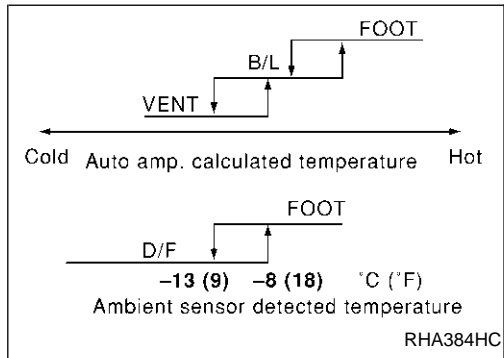

COMPONENT DESCRIPTION

NFHA0184

The mode door motor is attached to the heater unit. It rotates so that air is discharged from the outlet set by the auto amplifier. Motor rotation is conveyed to a link which activates the mode door.

DIAGNOSTIC PROCEDURE FOR AIR MIX DOOR MOTOR, MODE DOOR MOTOR AND INTAKE DOOR MOTOR CIRCUIT

NFHA0185

SYMPTOM: Air mix door motor, mode door motor and/or intake door motor does not operate normally.

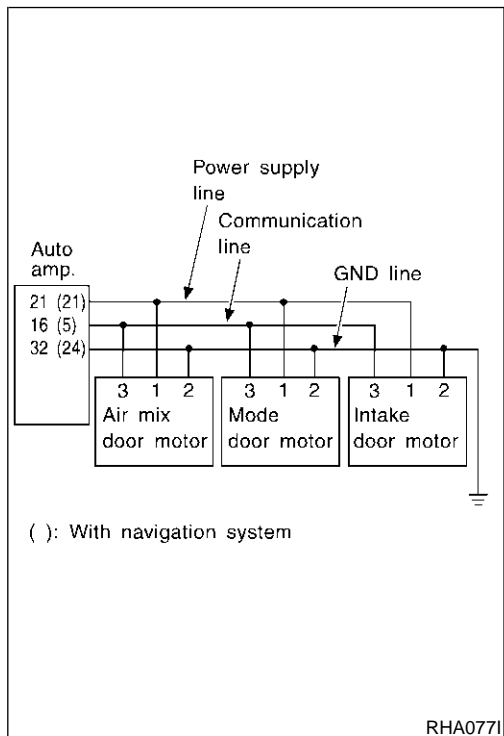

1	CHECK POWER SUPPLY FOR AUTO AMP. (LCU) SIDE	<p>Do approx. 12 volts exist between auto amp. (LCU) harness connector terminal No. 21 and ground?</p> <div style="text-align: center;"> <p>Auto amp. connector (M60) or (M171)</p> </div> <p style="text-align: right;">RHA373HA</p> <p style="text-align: center;">Yes or No</p>
Yes	▶	GO TO 2.
No	▶	Replace auto amp. (LCU).

2	CHECK SIGNAL FOR AUTO AMP. (LCU) SIDE	<p>Do approx. 5.5 volts exist between auto amp. (LCU) harness connector terminal No. 16 or 5 and ground?</p> <div style="display: flex; justify-content: space-around; align-items: flex-start;"> <div style="text-align: center;"> <p>Auto amp. connector (M59)</p> <p>Without navigation system</p> </div> <div style="text-align: center;"> <p>Auto amp. connector (M170)</p> <p>With navigation system</p> </div> </div> <p style="text-align: right;">RHA050I</p> <p style="text-align: center;">Yes or No</p>
Yes	▶	GO TO 3.
No	▶	Replace auto amp. (LCU).

3	CHECK POWER SUPPLY FOR MOTOR SIDE	<p>Do approx. 12 volts exist between door motor (LCU) harness connector terminal No. 1 and ground?</p> <div style="text-align: center;"> <p>Mode door motor connector (M49) or air mix door motor connector (M51) Intake door motor connector (M84)</p> </div> <p style="text-align: right;">RHA375H</p> <p style="text-align: center;">Yes or No</p>
Yes	▶	GO TO 4.
No	▶	Repair harness or connector.

GI
MA
EM
LC
EC
FE
CL
MT
AT
AX
SU
BR
ST
RS
BT
HA
SC
EL
IDX

Mode Door Motor (Cont'd)

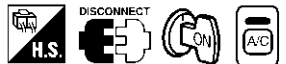
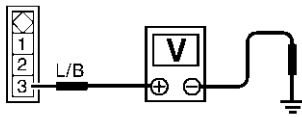
4	CHECK SIGNAL FOR MOTOR SIDE	
<p>Do approx. 5.5 volts exist between door motor (LCU) harness connector terminal No. 3 and ground?</p> <div style="text-align: center;">  <p>Mode door motor connector (M49), air mix door motor connector (M51) or Intake door motor (M84)</p>  </div> <p style="text-align: right;">RHA376HD</p>		
Yes or No		
Yes	▶	GO TO 5.
No	▶	Repair harness or connector.

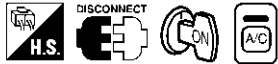
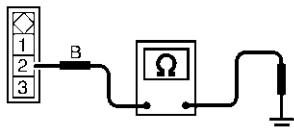
5	CHECK MOTOR GROUND CIRCUIT	
<p>Does continuity exist between door motor (LCU) harness connector terminal No. 2 and ground?</p> <div style="text-align: center;">  <p>Mode door motor connector (M49) or air mix door motor connector (M51) Intake door motor (M84)</p>  </div> <p style="text-align: right;">RHA377H</p>		
Yes or No		
Yes	▶	GO TO 6.
No	▶	Repair harness or connector.

6	CHECK MOTOR OPERATION	
<p>Disconnect and reconnect the motor connector and confirm the motor operation.</p> <p style="text-align: center;">OK or NG</p>		
OK (Return to operate normally.)	▶	Poor contacting the motor connector
NG (Does not operate normally.)	▶	GO TO 7.

TROUBLE DIAGNOSES

AUTO

Mode Door Motor (Cont'd)

7	CHECK MODE DOOR MOTOR AND AIR MIX DOOR MOTOR OPERATION	
1. Disconnect the intake door motor connector. 2. Reconnect the mode door motor and air mix door motor connector and confirm the mode door motor and air mix door motor operation.		
OK or NG		
OK (Mode door motor and air mix door motor operate normally.)	▶	Replace the intake door motor.
NG (Mode door motor and air mix door motor do not operate normally.)	▶	GO TO 8.

GI
MA
EM
LC

8	CHECK AIR MIX DOOR MOTOR AND INTAKE DOOR MOTOR OPERATION	
1. Disconnect the mode door motor connector. 2. Reconnect the intake door motor and confirm the air mix door motor and intake door motor operation.		
OK or NG		
OK (Air mix door motor and intake door motor operate normally.)	▶	Replace mode door motor.
NG (Air mix door motor and intake door motor do not operate normally.)	▶	GO TO 9.

EC
FE
CL
MT
AT

9	CHECK INTAKE DOOR MOTOR AND MODE DOOR MOTOR OPERATION	
1. Disconnect the air mix door motor connector. 2. Reconnect the mode door motor and confirm the intake door motor and mode door motor operation.		
OK or NG		
OK (Intake door motor and mode door motor operate normally.)	▶	Replace air mix door motor.
NG (Intake door motor and mode door motor do not operate normally.)	▶	Replace auto amp.

AX
SU
BR
ST
RS

BT

HA

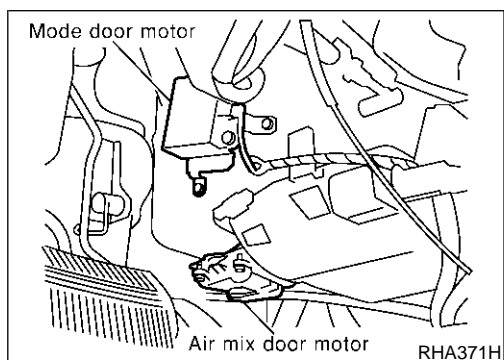

CONTROL LINKAGE ADJUSTMENT

Mode Door

NFHA0186

NFHA0186S01

1. Install mode door motor on heater unit and connect it to main harness.
2. Set up code No. in Self-diagnosis STEP 4. Refer to HA-44.
3. Move side link by hand and hold mode door in DEF mode.
4. Attach mode door motor rod to side link rod holder.
5. Make sure mode door operates properly when changing from code No. 44 to 45 by pushing DEF switch.

SC
EL
IDX

TROUBLE DIAGNOSES

AUTO

Mode Door Motor (Cont'd)

41	42	43	44	45	46
VENT	B/L	B/L	FOOT	D/F	DEF

Air Mix Door Motor

TROUBLE DIAGNOSIS PROCEDURE FOR AIR MIX DOOR (LAN)

=NFHA0187

SYMPTOM:

- Discharge air temperature does not change.
- Air mix door motor does not operate.

Inspection Flow

Without Navigation System

NFHA0187S01

NFHA0187S0101

1. Confirm symptom by performing the following operational check.

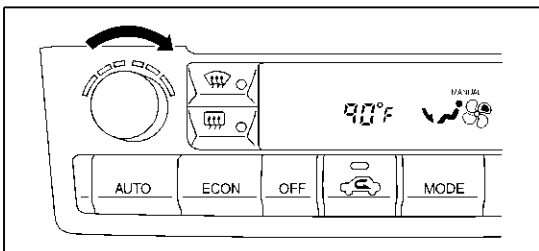

OPERATIONAL CHECK

Temperature increase

- a. Turn the temperature dial clockwise until 32°C (90°F) is displayed.
- b. Check for hot air at discharge air outlets.

Temperature decrease

- a. Turn the temperature dial counterclockwise until 18°C (60°F) is displayed.
- b. Check for cold air at discharge air outlets.

**If OK (symptom cannot be duplicated), perform complete operational check (*10).
If NG (symptom is confirmed), continue with STEP-2 following.**

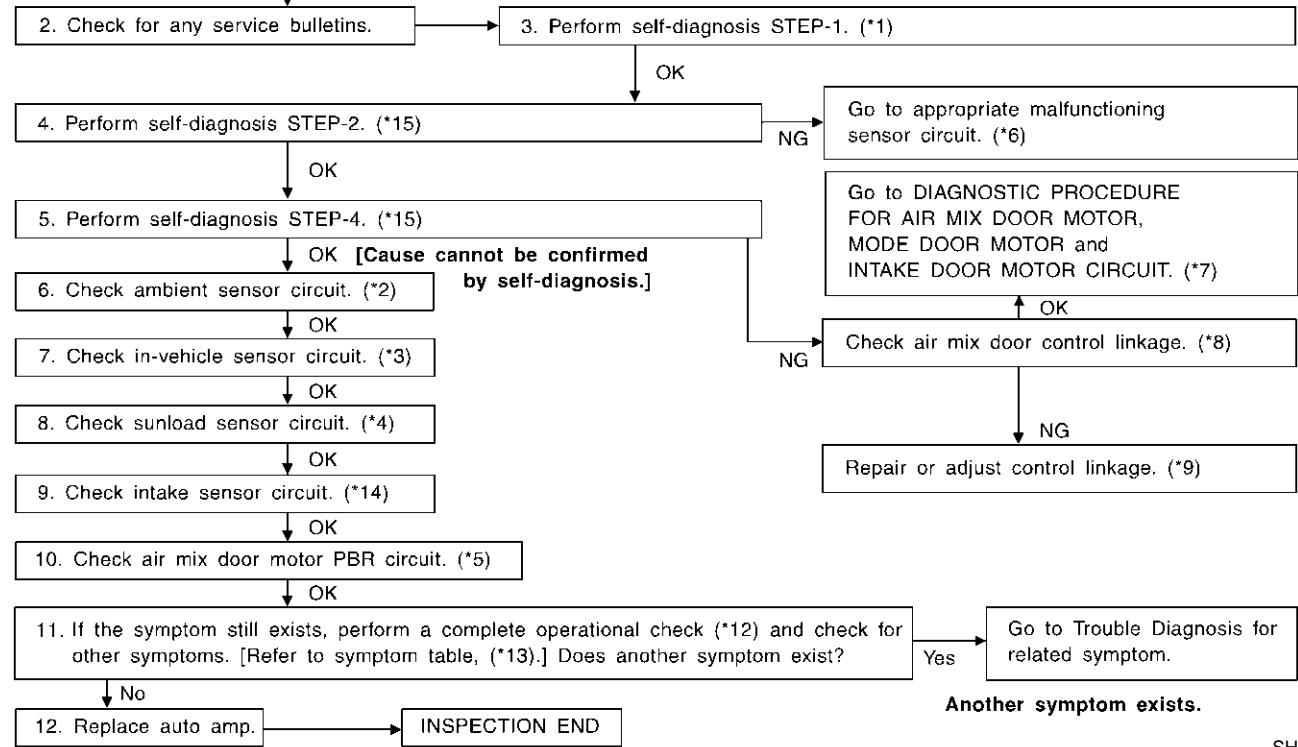
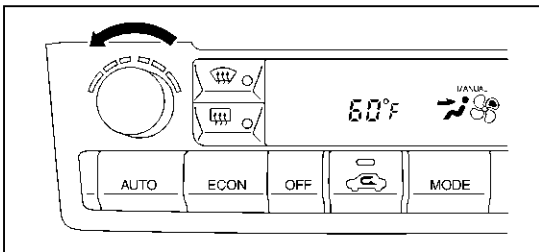

- *1: HA-43
- *2: HA-124
- *3: HA-127
- *4: HA-130
- *5: HA-136

- *7: HA-78
- *8: HA-86
- *9: HA-86
- *10: HA-65

- *12: HA-65
- *13: HA-64
- *14: HA-134
- *15: HA-44

*6: FUNCTION CONFIRMATION PROCEDURE (HA-44), see No. 13.

GI
MA
EM
EM
LC
EC
FE
CL
MT
AT
AX
SU
BR
ST
RS
BT
HA
SC
EL
IDX

1. Confirm symptom by performing the following operational check.

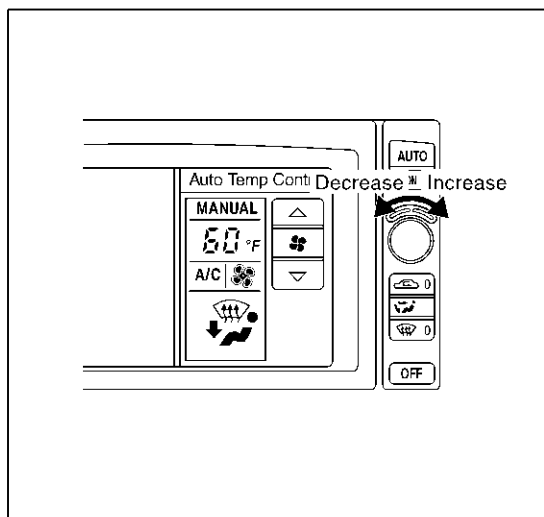

OPERATIONAL CHECK

Temperature increase

- a. Turn the temperature dial clockwise until 32°C (90°F) is displayed.
- b. Check for hot air at discharge air outlets.

Temperature decrease

- a. Turn the temperature dial counterclockwise until 18°C (60°F) is displayed.
- b. Check for cold air at discharge air outlets.

**If OK (symptom cannot be duplicated), perform complete operational check (*10).
If NG (symptom is confirmed), continue with STEP-2 following.**

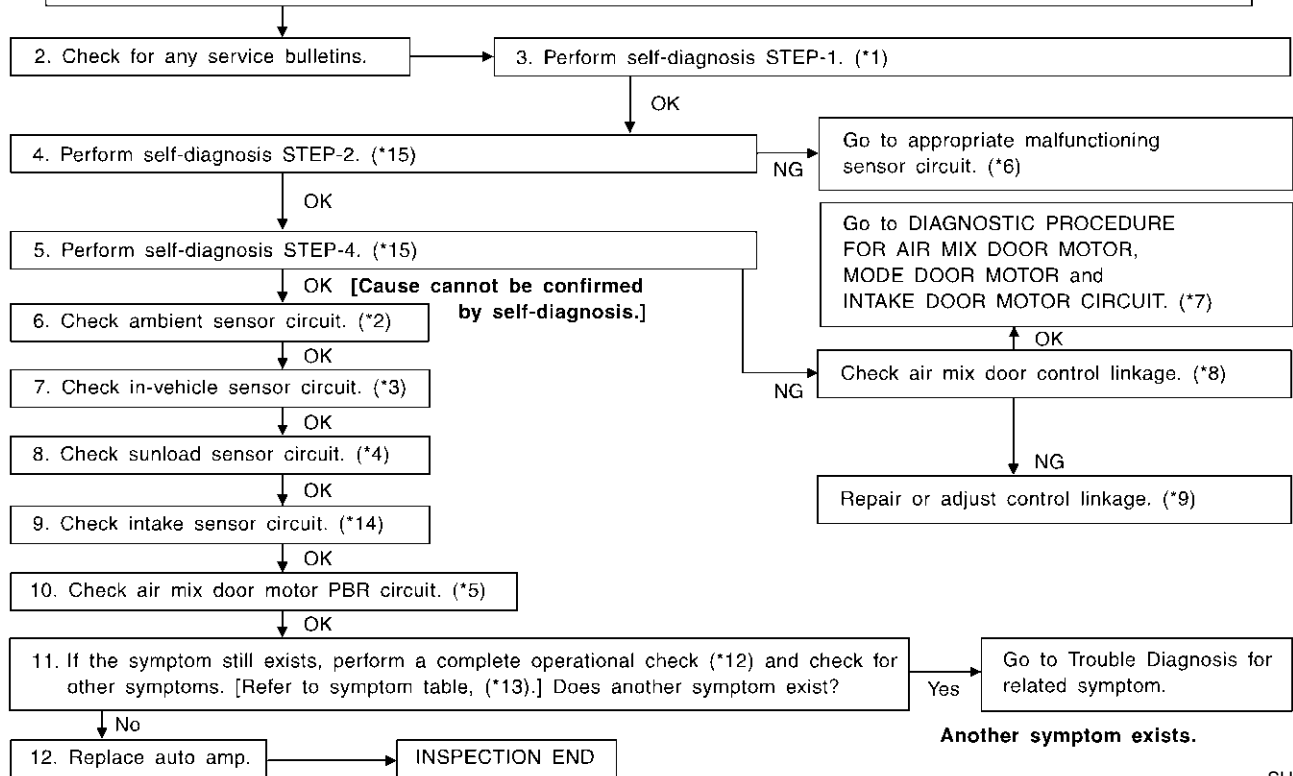

*1: HA-53

*2: HA-124

*3: HA-127

*4: HA-130

*5: HA-136

*6: FUNCTION CONFIRMATION PROCEDURE (HA-54), see No. 14.

*7: HA-78

*8: HA-86

*9: HA-86

*10: HA-67

*12: HA-67

*13: HA-64

*14: HA-134

*15: HA-54

SYSTEM DESCRIPTION

Component Parts

Air mix door control system components are:

- 1) Auto amp.
- 2) Air mix door motor (LCU)
- 3) In-vehicle sensor
- 4) Ambient sensor
- 5) Sunload sensor
- 6) Intake sensor

System Operation

The auto amplifier receives data from each of the sensors. The amplifier sends air mix door, mode door, intake door opening angle data to the air mix door motor LCU, mode door motor LCU and intake door motor LCU. The air mix door motor, mode door motor and intake door motor read their respective signals according to the address signal. Opening angle indication signals received from the auto amplifier and each of the motor position sensors are compared by the LCUs in each motor with the existing decision and opening angles. Subsequently, HOT/COLD or DEFROST/VENT operation is selected. The new selection data is returned to the auto amplifier.

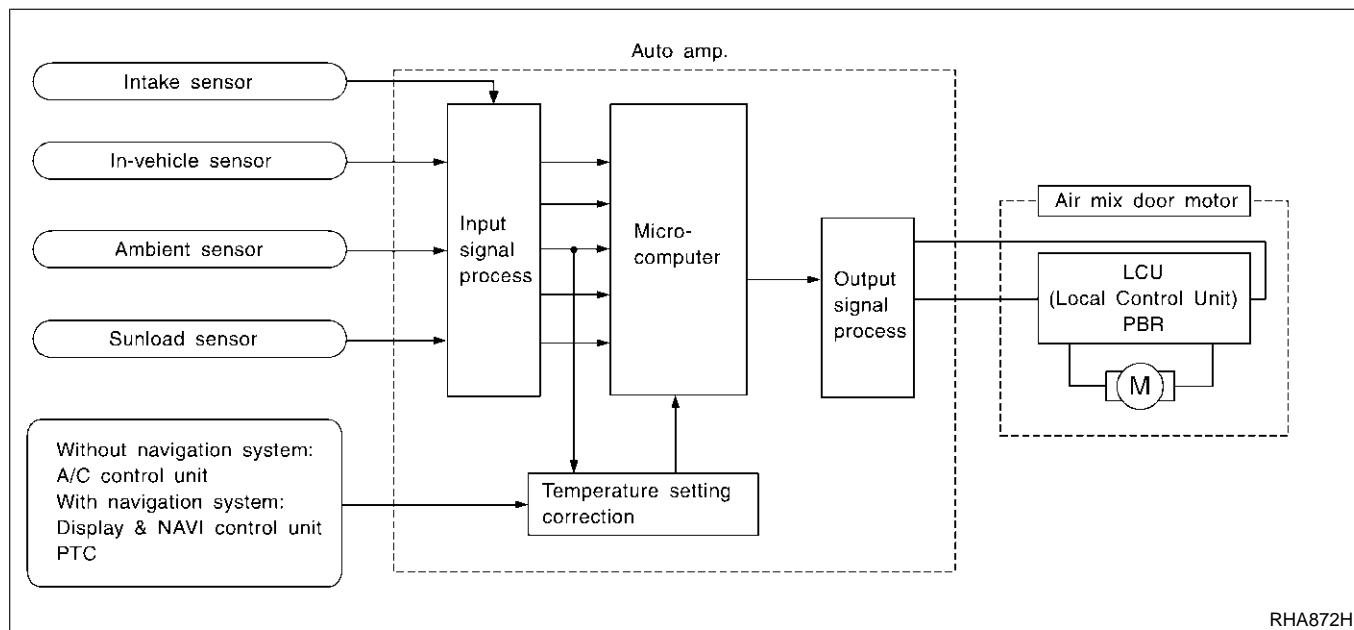

Air Mix Door Control Specification

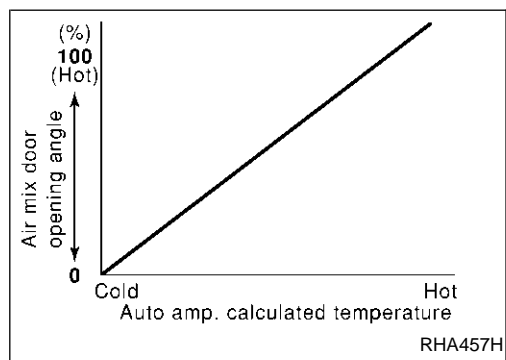

GI
MA
EM
LC
EC
FE
CL
MT
AT
AX
SU
BR
ST
RS
BT
HA
SC
EL
IDX

Air Mix Door Motor (Cont'd)

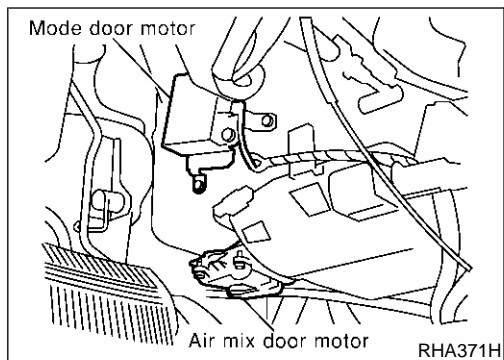

COMPONENT DESCRIPTION

NFHA0189

The air mix door motor is attached to the heater unit. It rotates so that the air mix door is opened or closed to a position set by the auto amplifier. Motor rotation is then conveyed through a shaft and the air mix door position is then fed back to the auto amplifier by PBR built-in air mix door motor.

DIAGNOSTIC PROCEDURE

NFHA0248

SYMPTOM: Discharge air temperature does not change.

- Refer to HA-78.

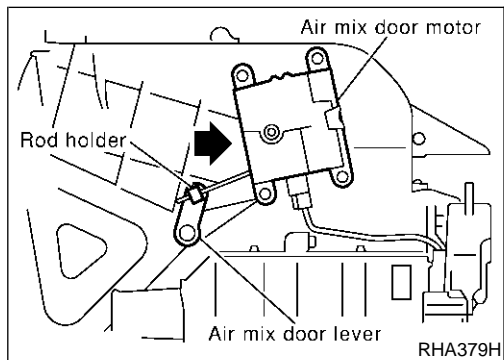

CONTROL LINKAGE ADJUSTMENT

NFHA0190

Air Mix Door

NFHA0190S01

1. Install air mix door motor on heater unit and connect it to main harness.
2. Set up code No. 41 in Self-diagnosis STEP 4. Refer to HA-43.
3. Move air mix door lever by hand and hold it in full cold position.
4. Attach air mix door lever to rod holder.
5. Make sure air mix door operates properly when changing from code No. 41 to 45 by pushing DEF switch.

41	42	43	44	45	46
Full cold			Full hot		

Intake Door Motor

TROUBLE DIAGNOSIS PROCEDURE FOR INTAKE DOOR (LAN)

=NFHA0191

SYMPTOM:

- Intake door does not change.
- Intake door motor does not operate normally.

Inspection Flow

Without Navigation System

NFHA0191S01

NFHA0191S0101

1. Confirm symptom by performing the following operational check.

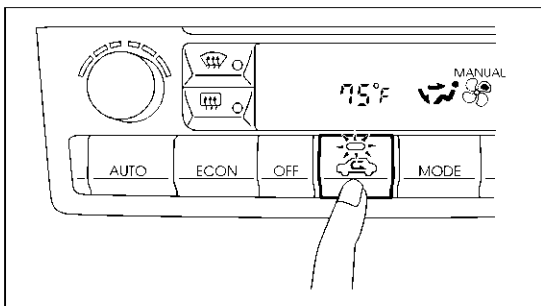

- a. Press REC switch. Recirculation indicator should illuminate.
- b. Listen for intake door position change (you should hear blower sound change slightly).

**If OK (symptom cannot be duplicated), perform complete operational check (*9).
If NG (symptom is confirmed), continue with STEP-2 following.**

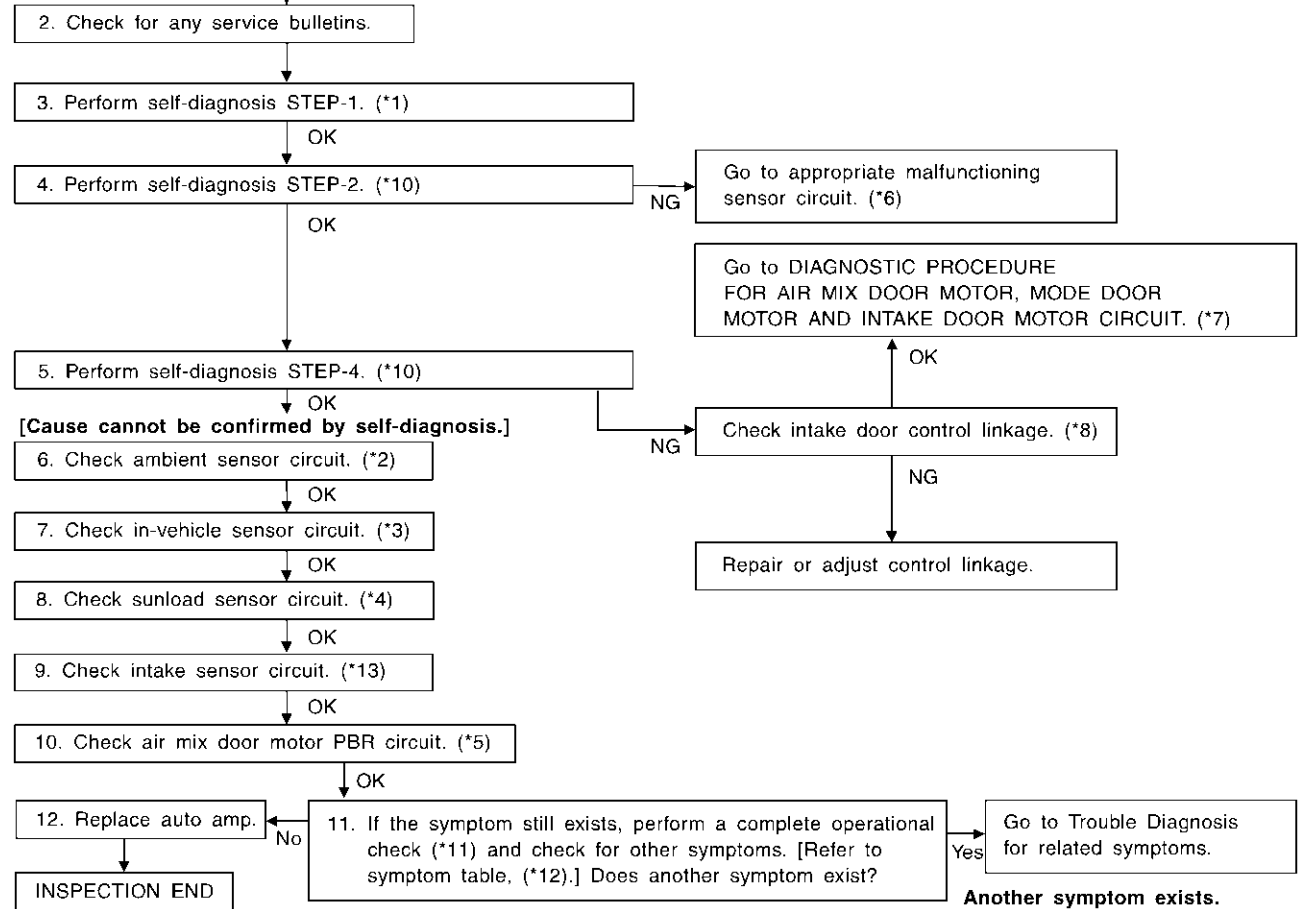

*1: HA-43
*2: HA-124
*3: HA-127
*4: HA-130
*5: HA-136

*6: FUNCTION CONFIRMATION PROCEDURE (HA-44), see No. 13.
*7: HA-78
*8: HA-90

*9: HA-65
*10: HA-44
*11: HA-65
*12: HA-64
*13: HA-134

SHA771F

1. Confirm symptom by performing the following operational check.

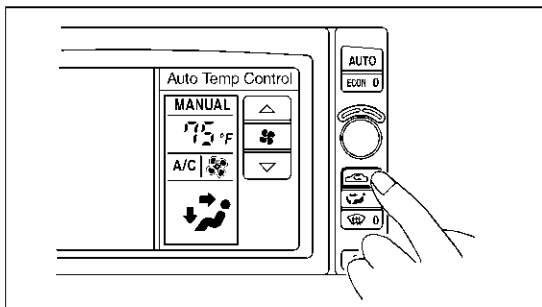

- a. Press REC switch. Recirculation indicator should illuminate.
- b. Listen for intake door position change (you should hear blower sound change slightly).

If OK (symptom cannot be duplicated), perform complete operational check (*9).
If NG (symptom is confirmed), continue with STEP-2 following.

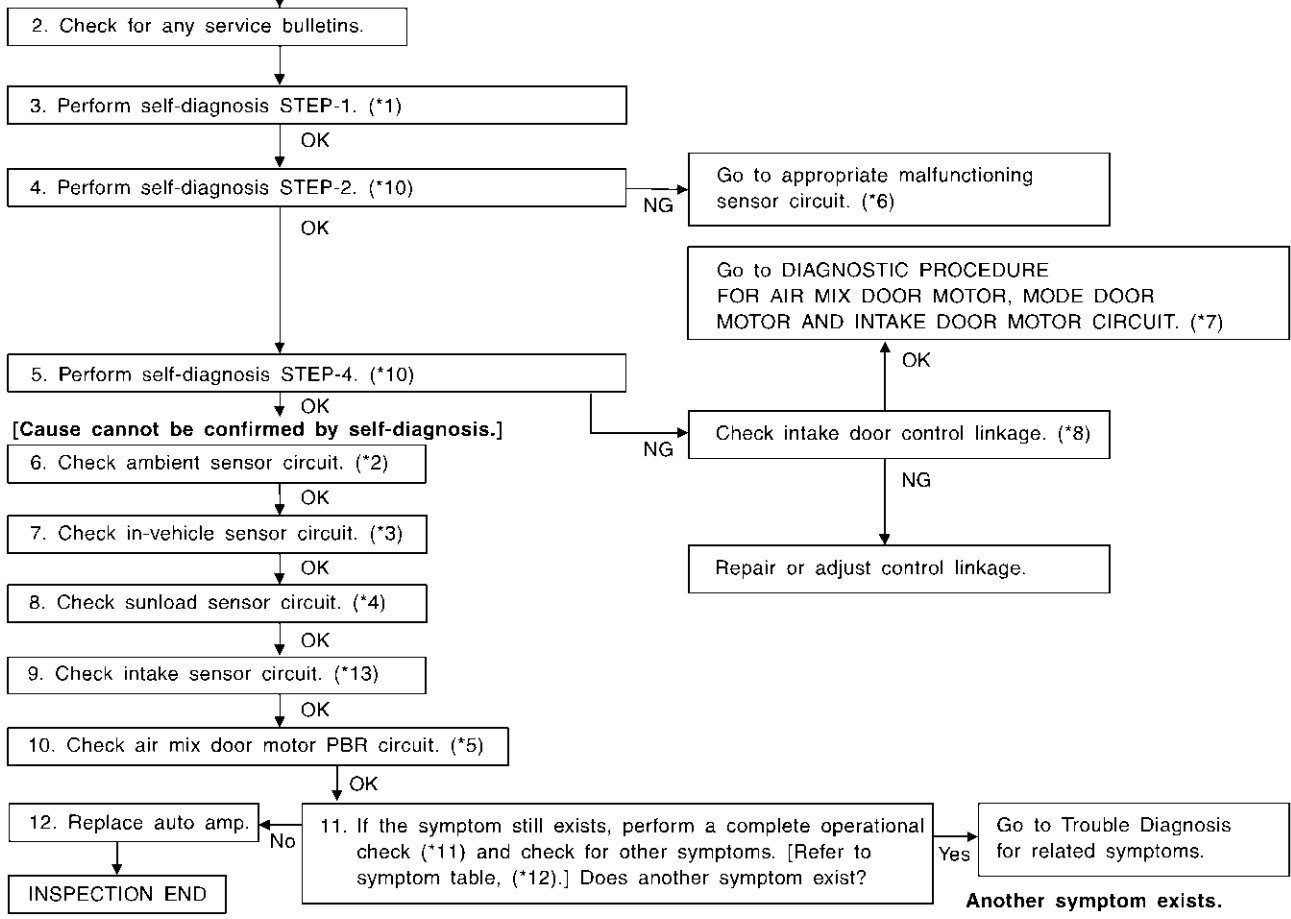

*1: HA-53
 *2: HA-124
 *3: HA-127
 *4: HA-130
 *5: HA-136

*6: FUNCTION CONFIRMATION PROCEDURE (HA-54), see No. 14.
 *7: HA-78
 *8: HA-90

*9: HA-67
 *10: HA-54
 *11: HA-67
 *12: HA-64
 *13: HA-134

SYSTEM DESCRIPTION

Component Parts

Intake door control system components are:

- 1) Auto amp.
- 2) Intake door motor
- 3) In-vehicle sensor
- 4) Ambient sensor
- 5) Sunload sensor
- 6) Intake sensor

System Operation

The intake door control determines intake door position based on the ambient temperature, the intake air temperature and the in-vehicle temperature. When the ECON, DEFROST, or OFF switches are pushed, the auto amplifier sets the intake door at the "Fresh" position.

=NFHA0192

NFHA0192S01

NFHA0192S02

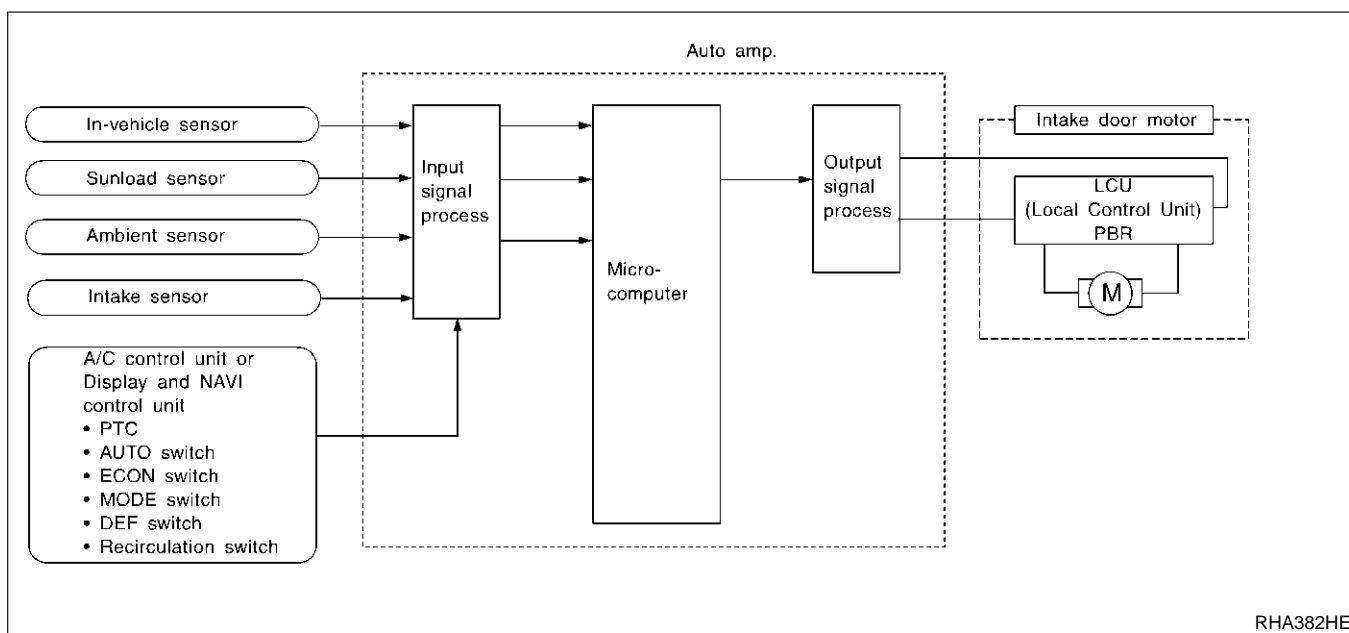

RHA382HE

Intake Door Control Specification

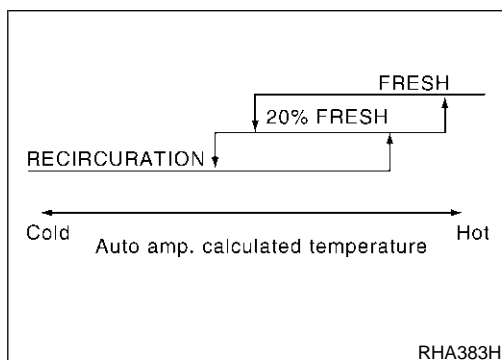

RHA383H

GI

MA

EM

LC

EC

FE

CL

MT

AT

AX

SU

BR

ST

RS

BT

HA

SC

EL

IDX

NFHA0192S03

Intake Door Motor (Cont'd)

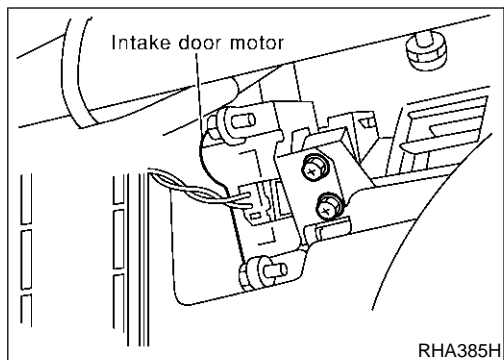

COMPONENT DESCRIPTION

The intake door motor is attached to the intake unit. It rotates so that air is drawn from inlets set by the auto amplifier. Motor rotation is conveyed to a lever which activates the intake door. NFHA0193

DIAGNOSTIC PROCEDURE

SYMPTOM: Intake door motor does not operate normally. NFHA0194

- Refer to HA-78.

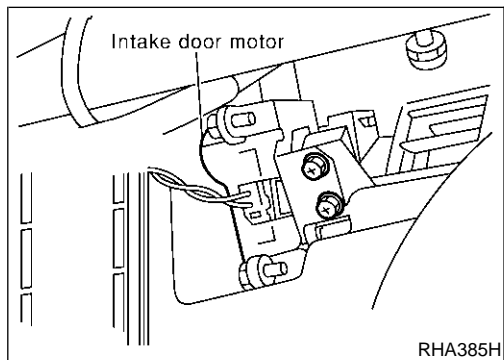

CONTROL LINKAGE ADJUSTMENT

Intake Door

1. Install intake door motor on intake unit and connect it to main harness. NFHA0195
2. Set up code No. 41 in Self-diagnosis STEP 4. Refer to HA-44. NFHA0195S01
3. Make sure intake door operates properly when changing from code No. 41 to 45 by pushing DEF switch.

41	42	43	44	45	46
REC	20% FRE			FRE	

Blower Motor

TROUBLE DIAGNOSIS PROCEDURE FOR BLOWER MOTOR

=NFHA0196

SYMPTOM:

- Blower motor operation is malfunctioning.
- Blower motor operation is malfunctioning under out of starting fan speed control.

Inspection Flow

Without Navigation System

NFHA0196S01

NFHA0196S0101

1. Confirm symptom by performing the following operational check.

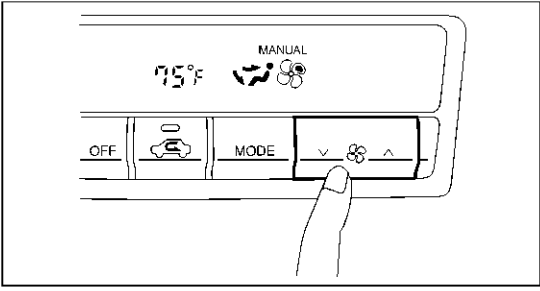

OPERATIONAL CHECK – Blower

a. Press fan switch (up side) one time. Blower should operate on low speed. The fan symbol should have one blade lit.

b. Press fan switch (up side) one more time, and continue checking blower speed and fan symbol until all speeds are checked.

c. Leave blower on MAX speed.

If OK (symptom cannot be duplicated), perform complete operational check (*12).

If NG (symptom is confirmed), continue with STEP-2 following.

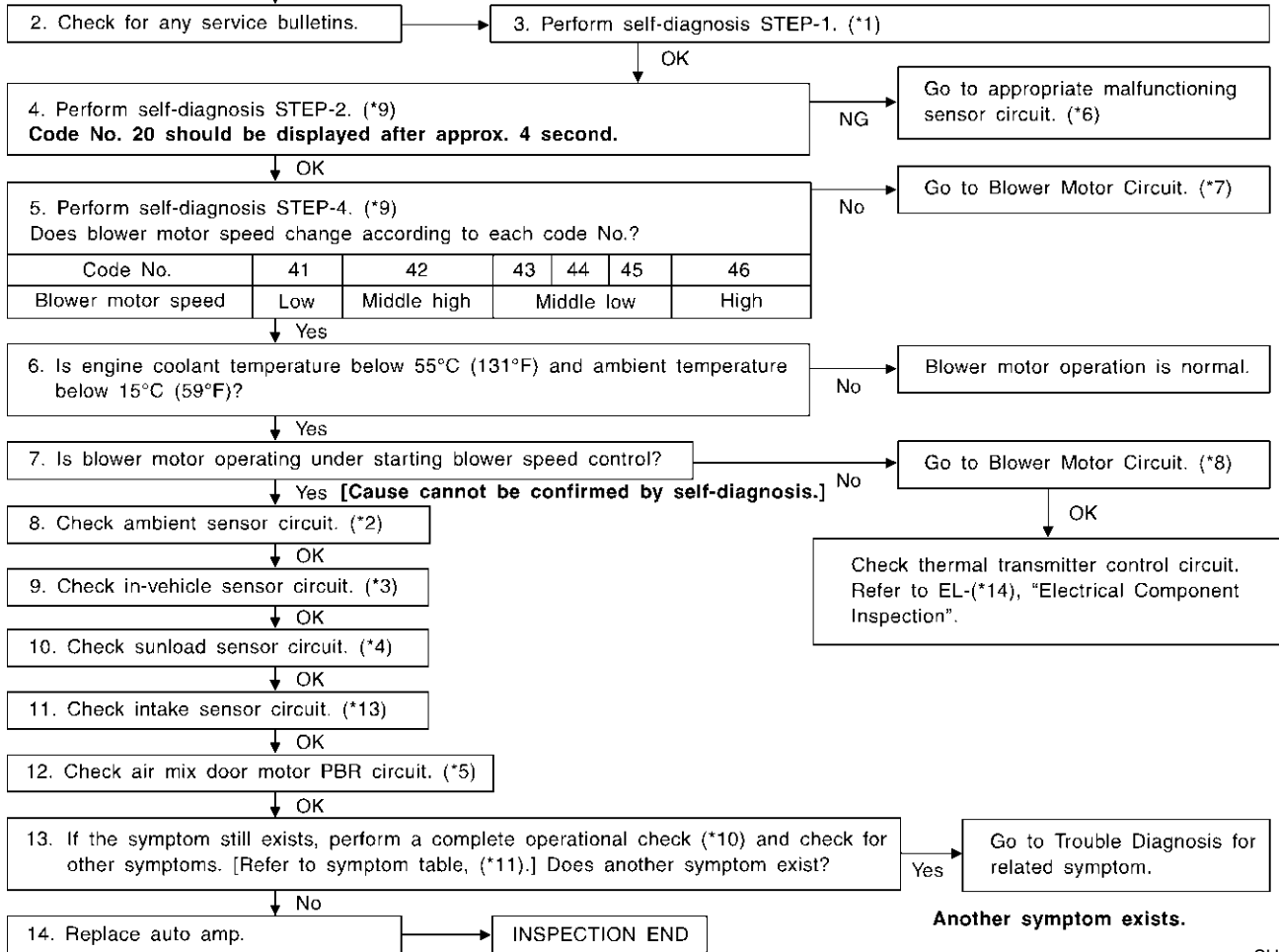

*1: HA-43

*2: HA-124

*3: HA-127

*4: HA-130

*5: HA-136

*6: FUNCTION CONFIRMATION PROCEDURE (HA-44), see No. 13.

*7: HA-94

*8: HA-94

*9: HA-44

*10: HA-65

*11: HA-64

*12: HA-65

*13: HA-134

*14: EL-130

Another symptom exists.

SHA773F

GI
MA
EM
LC
EC
FE
CL
MT
AT
AX
SU
BR
ST
RS
BT
HA
SC
EL
IDX

1. Confirm symptom by performing the following operational check.

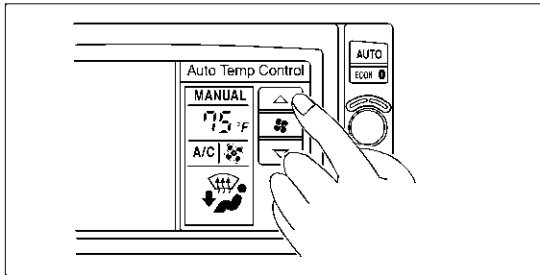

OPERATIONAL CHECK – Blower

- a. Press fan switch (up side) one time. Blower should operate on low speed. The fan symbol should have one blade lit.
- b. Press fan switch (up side) one more time, and continue checking blower speed and fan symbol until all speeds are checked.
- c. Leave blower on MAX speed.

If OK (symptom cannot be duplicated), perform complete operational check (*12).

If NG (symptom is confirmed), continue with STEP-2 following.

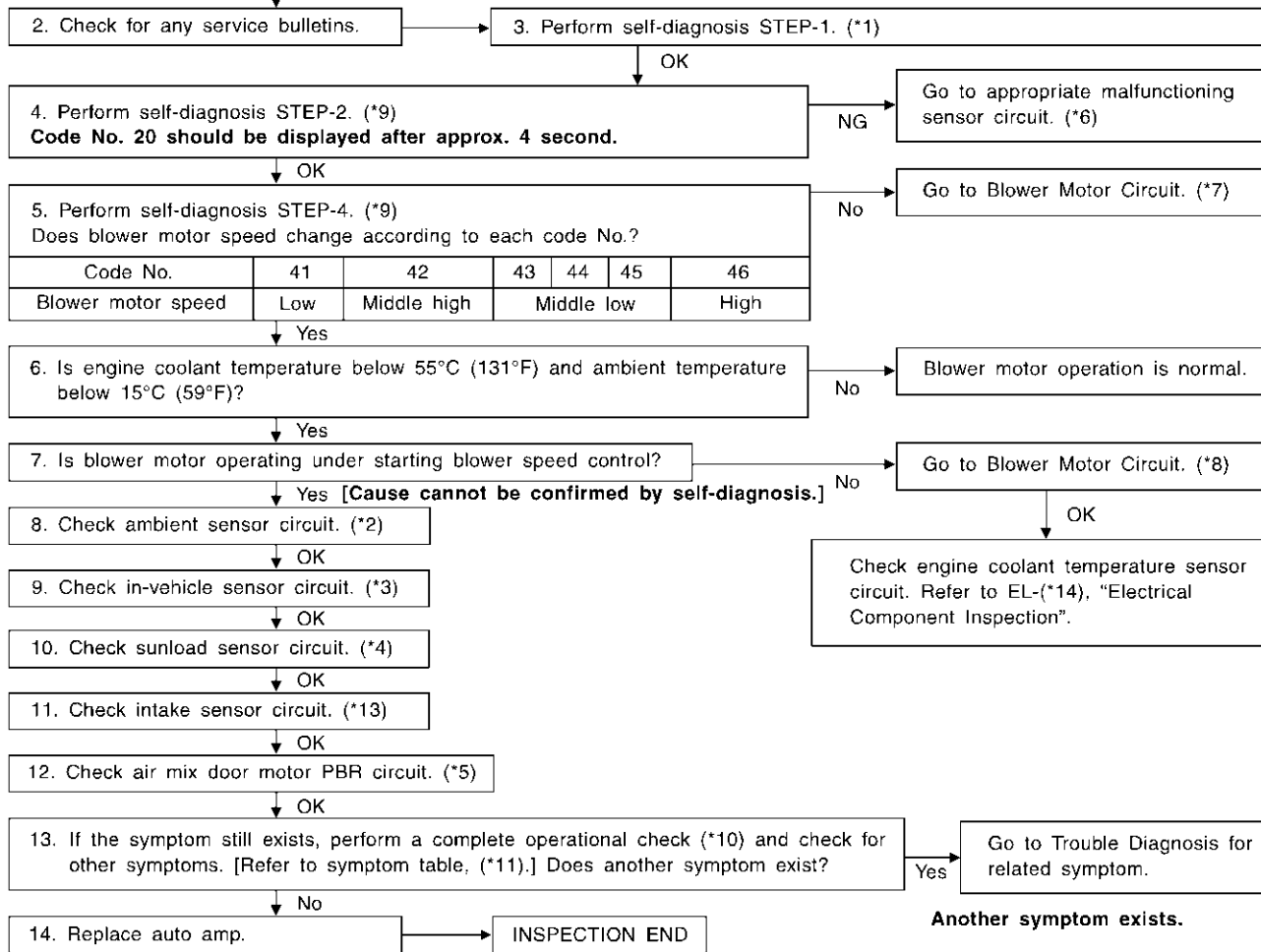

*1: HA-53

*2: HA-124

*3: HA-127

*4: HA-130

*5: HA-136

*6: FUNCTION CONFIRMATION PROCEDURE (HA-54), see No. 14.

*7: HA-94

*8: HA-94

*9: HA-54

*10: HA-67

*11: HA-64

*12: HA-67

*13: HA-134

*14: EL-130

SYSTEM DESCRIPTION

Component parts

Fan speed control system components are:

- 1) Auto amp.
- 2) Fan control amp.
- 3) A/C LAN system (PBR built-in air mix door motor and mode door motor)
- 4) In-vehicle sensor
- 5) Ambient sensor
- 6) Sunload sensor
- 7) Intake sensor

System Operation

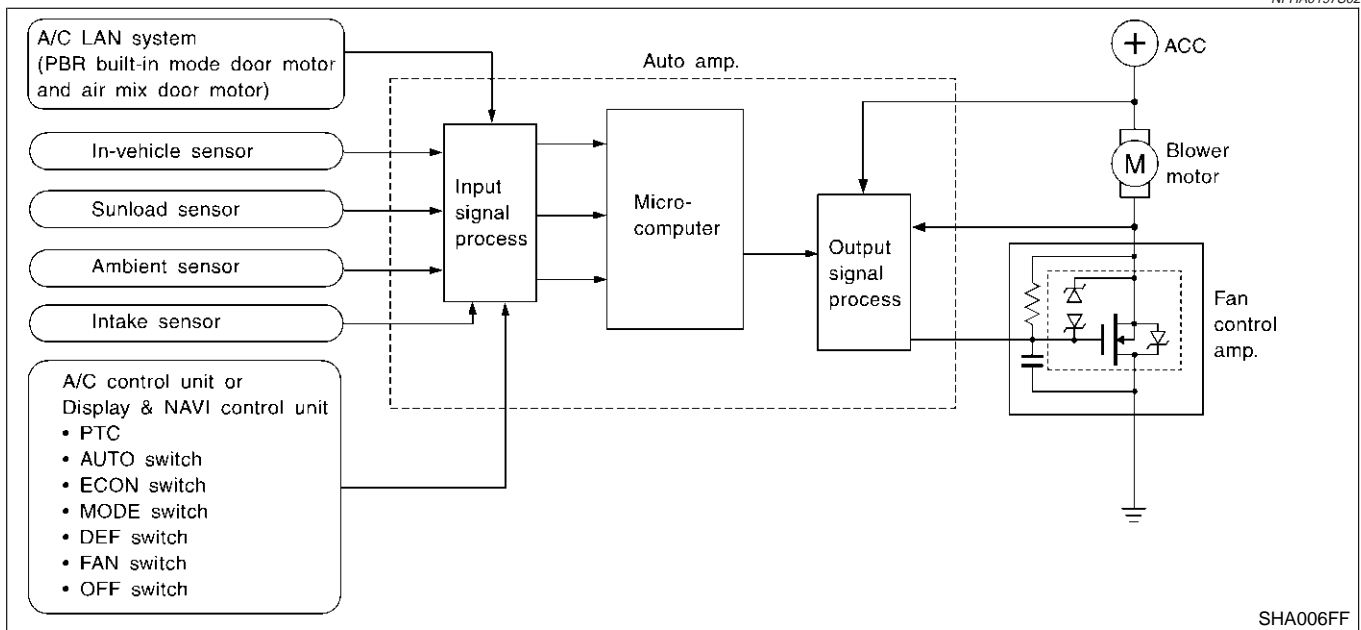

Automatic Mode

In the automatic mode, the blower motor speed is calculated by the automatic amplifier based on inputs from the PBR, in-vehicle sensor, sunload sensor, intake sensor and ambient sensor. The blower motor applied voltage ranges from approximately 5 volts (lowest speed) to 12 volts (highest speed).

The control blower speed (in the range of 5 to 12V), the automatic amplifier supplies a gate voltage to the fan control amplifier. Based on this voltage, the fan control amplifier controls the voltage supplied to the blower motor.

Starting Fan Speed Control

Start Up From "COLD SOAK" Condition (Automatic mode)

In a cold start up condition where the engine coolant temperature is below 55°C (131°F), the blower will not operate for a short period of time (up to 150 seconds). The exact start delay time varies depending on the ambient and engine coolant temperature.

In the most extreme case (very low ambient) the blower starting delay will be 126 seconds as described above. After this delay, the blower will operate at low speed until the engine coolant temperature rises above 55°C (131°F), at which time the blower speed will increase to the objective speed.

Start Up From Normal or "HOT SOAK" Condition (Automatic mode)

The blower will begin operation momentarily after the AUTO button is pushed. The blower speed will gradually rise to the objective speed over a time period of 3 seconds or less (actual time depends on the objective blower speed).

NFHA0197S0402

Blower Speed Compensation Sunload

When the in-vehicle temperature and the set temperature are very close, the blower will be operating at low speed. The low speed will vary depending on the sunload. During conditions of high sunload, the blower low speed is "normal" low speed (approx. 6V). During low or no sunload conditions, the low speed will drop to "low" low speed (approx. 5V).

NFHA0197S05

NFHA0197S0501

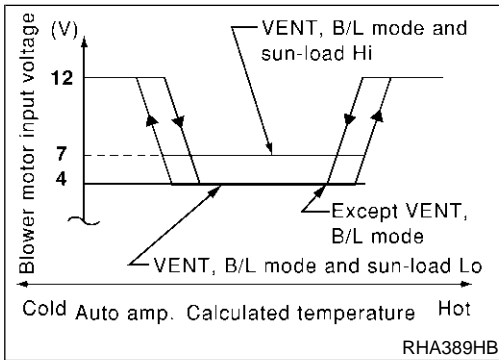

RHA389HB

Fan Speed Control Specification

NFHA0197S06

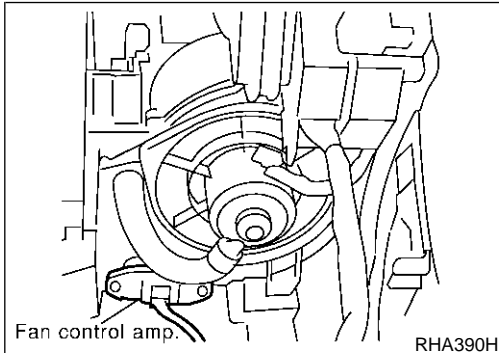

Fan control amp.

RHA390H

COMPONENT DESCRIPTION

NFHA0198

Fan Control Amplifier

NFHA0198S01

The fan control amplifier is located on the cooling unit. The fan control amp. receives a gate voltage from the auto amp. to steplessly maintain the blower fan motor voltage in the 5 to 12 volt range (approx.).

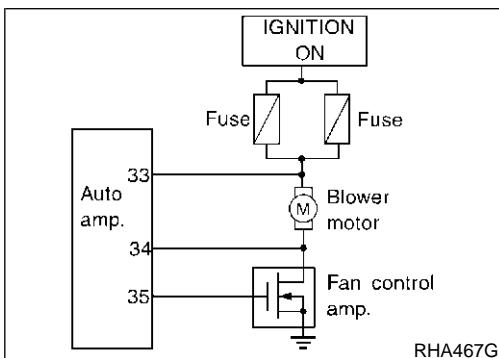

RHA467G

DIAGNOSTIC PROCEDURE

NFHA0199

SYMPTOM: Blower motor operation is malfunctioning under Starting Fan Speed Control.

1	CHECK POWER SUPPLY FOR FAN CONTROL AMP.	
<p>Disconnect fan control amp. harness connector. Do approx. 12 volts exist between fan control amp. harness connector terminal No. 1 and ground?</p> <div style="text-align: center;"> </div> <p style="text-align: right;">RHA392H</p> <p style="text-align: center;">Yes or No</p>		
Yes	▶	GO TO 2.
No	▶	GO TO 8.

2	CHECK BODY GROUND CIRCUIT FOR FAN CONTROL AMP.	
<p>Does continuity exist between fan control amp. harness connector terminal No. 3 and ground?</p> <div style="text-align: center;"> </div> <p style="text-align: right;">RHA393H</p> <p style="text-align: center;">Yes or No</p>		
Yes	▶	Reconnect fan control amp. harness connector. And GO TO 3.
No	▶	Repair harness or connector.

GI
 MA
 EM
 LC
 EC
 FE
 CL
 MT
 AT
 AX
 SU
 BR
 ST
 RS
 BT
 HA
 SC
 EL
 IDX

Blower Motor (Cont'd)

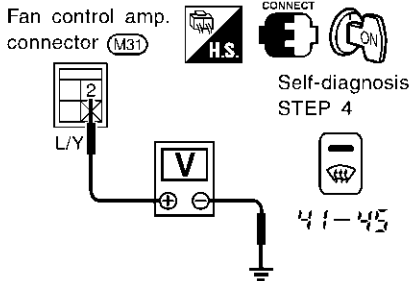
3	CHECK VOLTAGE FOR FAN CONTROL AMP.											
<p>Set up Self-diagnosis STEP 4. Measure voltage across fan control amp. harness connector terminal No. 2 and ground.</p>												
												
<table border="1" style="margin: auto;"> <thead> <tr> <th rowspan="2">Code No.</th> <th colspan="2">Terminal No.</th> <th rowspan="2">Voltage</th> </tr> <tr> <th>(+)</th> <th>(-)</th> </tr> </thead> <tbody> <tr> <td style="text-align: center;">41-45</td> <td style="text-align: center;">(2)</td> <td style="text-align: center;">Body ground</td> <td style="text-align: center;">Approx. 2.5 - 3V</td> </tr> </tbody> </table>			Code No.	Terminal No.		Voltage	(+)	(-)	41-45	(2)	Body ground	Approx. 2.5 - 3V
Code No.	Terminal No.			Voltage								
	(+)	(-)										
41-45	(2)	Body ground	Approx. 2.5 - 3V									
RHA786H												
OK or NG												
OK	▶	GO TO 4.										
NG	▶	1. If the voltage is less than 2.5V, replace fan control amp. 2. If the voltage is more than 3.0V, GO TO 4. 3. Go to "FUNCTION CONFIRMATION PROCEDURE", "Self-diagnosis", HA-44; Without Navigation System or HA-54; With Navigation System and perform self-diagnosis STEP 4. Confirm that blower motor operation is normal.										

4	CHECK FAN CONTROL AMP.	
Refer to HA-100.		
OK or NG		
OK	▶	GO TO 5.
NG	▶	1. Replace fan control amp. 2. Go to "FUNCTION CONFIRMATION PROCEDURE", "Self-diagnosis", HA-44; Without Navigation System or HA-54; With Navigation System and perform self-diagnosis STEP 4. Confirm that blower motor operation is normal.

5	CHECK FAN CONTROL AMP. CIRCUIT BETWEEN FAN CONTROL AMP. AND AUTO AMP. (LCU)	
	<p>1. Disconnect auto amp. (LCU) and fan control amp. harness connector.</p> <p>2. Check circuit continuity between auto amp. (LCU) harness connector terminal No. 35 and fan control amp. harness connector terminal No. 2.</p> <div style="text-align: center; margin: 10px 0;"> <p style="font-size: small;">Fan control amp. connector (M31) Auto amp. connector (M60) or (M17)</p> </div> <p style="text-align: right; margin-top: 10px;">SHA375FA</p> <p style="text-align: center; margin-top: 10px;">Continuity should exist. If OK, check harness for short.</p> <p style="text-align: center; margin-top: 10px;">OK or NG</p>	<p>GI</p> <p>MA</p> <p>EM</p> <p>LC</p> <p>EC</p> <p>FE</p> <p>CL</p> <p>MT</p> <p>AT</p>
OK	▶ GO TO 6.	
NG	▶ Repair harness or connector.	

6	CHECK FAN FEED BACK CIRCUIT	
	<p>Reconnect auto amp. (LCU) harness connector.</p> <p>Do approx. 12 volts exist between auto amp. (LCU) harness connector terminal No. 33 and ground?</p> <div style="text-align: center; margin: 10px 0;"> <p style="font-size: small;">Auto amp. connector (M60) or (M17)</p> </div> <p style="text-align: right; margin-top: 10px;">SHA371FA</p> <p style="text-align: center; margin-top: 10px;">Yes or No</p>	<p>SU</p> <p>BR</p> <p>ST</p> <p>RS</p> <p>BT</p>
Yes	▶ GO TO 7.	
No	▶ Check power supply circuit and 15A fuses (Nos. 51 and 52, located in the fuse and fusible link box). Refer to EL-12, "Wiring Diagram — POWER —".	
	<ul style="list-style-type: none"> ● If OK, check for open circuit in wiring harness. Repair or replace as necessary. ● If NG, replace fuse and check wiring harness for short circuit. Repair or replace as necessary. 	<p>HA</p> <p>SC</p> <p>EL</p> <p>IDX</p>

Blower Motor (Cont'd)

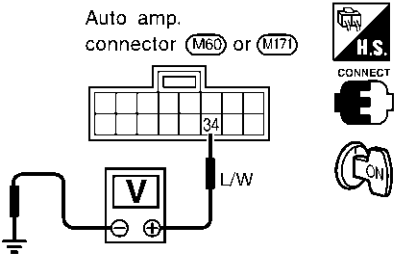
7	CHECK POWER SUPPLY FOR AUTO AMP.	
Do approx. 12 volts exist between auto amp. harness connector terminal No. 34 and ground?		
		
SHA370FA		
Yes or No		
Yes	▶	1. Replace auto amp. 2. Go to "FUNCTION CONFIRMATION PROCEDURE", "Self-diagnosis", HA-44; Without Navigation System or HA-54; With Navigation System and perform self-diagnosis STEP-4. Confirm that blower motor operation is normal.
No	▶	GO TO 10.

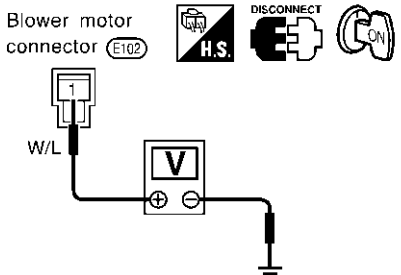
8	CHECK POWER SUPPLY FOR BLOWER MOTOR	
Disconnect blower motor harness connector. Do approx. 12 volts exist between blower motor harness connector terminal No. 1 and ground?		
		
RHA091GE		
Yes or No		
Yes	▶	GO TO 9.
No	▶	Check power supply circuit and 15A fuses (No. 51 and 52, located in the fuse and fusible link box). <ul style="list-style-type: none"> ● Check blower motor relay. ● If OK, check for open circuit in wiring harness. Repair or replace as necessary. ● If NG, replace fuse and check wiring harness for short circuit. Repair or replace as necessary.

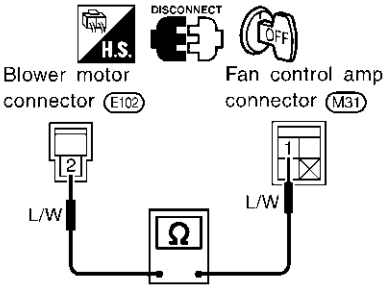
9	CHECK CIRCUIT CONTINUITY BETWEEN BLOWER MOTOR AND FAN CONTROL AMP.	
<p>Disconnect blower motor connector and auto amp. (LCU) connector. Check circuit continuity between blower motor harness connector terminal No. 2 and fan control amp. harness connector terminal No. 1.</p>		
		
RHA397H		
OK or NG		
OK	▶	<p>Check blower motor. (Refer to HA-99.)</p> <ol style="list-style-type: none"> 1. If NG, replace blower motor. 2. Go to "FUNCTION CONFIRMATION PROCEDURE", "Self-diagnosis", HA-44; Without Navigation System or HA-54; With Navigation System and perform self-diagnosis STEP-4. Confirm that blower motor operation is normal.
NG	▶	Repair harness or connector.

GI
 MA
 EM
 LC
 EC
 FE
 CL
 MT

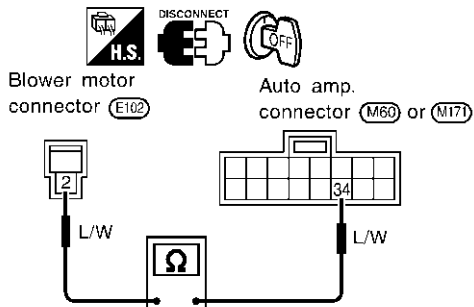
10	CHECK BLOWER MOTOR CIRCUIT BETWEEN BLOWER MOTOR AND AUTO AMP. (LCU)	
<p>Check circuit continuity between blower motor harness connector terminal No. 2 and auto amp. (LCU) harness connector terminal No. 34.</p>		
		
SHA372FA		
OK or NG		
<p>Continuity should exist. If OK, check harness for short.</p>		
OK	▶	INSPECTION END
NG	▶	Repair harness or connector.

AT
 AX
 SU
 BR
 ST
 RS
 BT
 HA

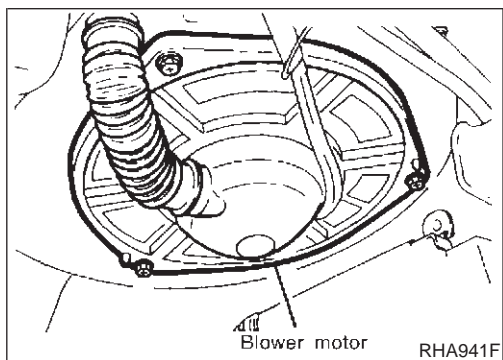

COMPONENT INSPECTION

Blower Motor

Confirm smooth rotation of the blower motor.

- Ensure that there are no foreign particles inside the intake unit.

NFHA0200
 NFHA0200S01

SC
 EL
 IDX

Blower Motor (Cont'd)

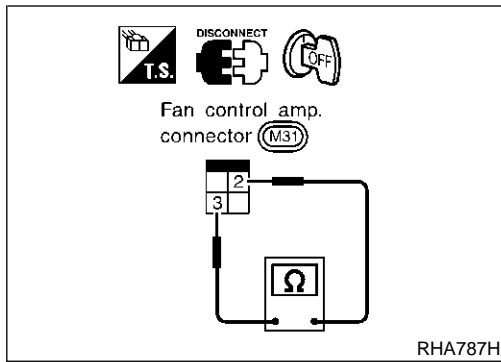

Fan Control Amp.

NFHA0200S02

Check continuity between terminals.

Ohmmeter terminal		Continuity
+	-	
Terminal No.		
2	3	Yes

Magnet Clutch

TROUBLE DIAGNOSIS PROCEDURE FOR MAGNET CLUTCH

SYMPTOM:

- Magnet clutch does not engage.

Inspection Flow

Without Navigation System

=NFHA0201

GI

MA

NFHA0201S01

EM

NFHA0201S0101

1. Confirm symptom by performing operational check.

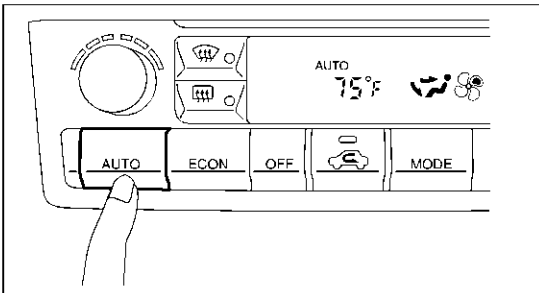

OPERATIONAL CHECK – AUTO mode

a. Press AUTO switch.

b. Display should indicate AUTO (not ECON). Confirm that the compressor clutch engages (audio or visual inspection). (Discharge air and blower speed will depend on ambient, in-vehicle and set temperatures.)

If OK (symptom cannot be duplicated), perform complete operational check (*9).

If NG (symptom is confirmed), continue with STEP-2 following.

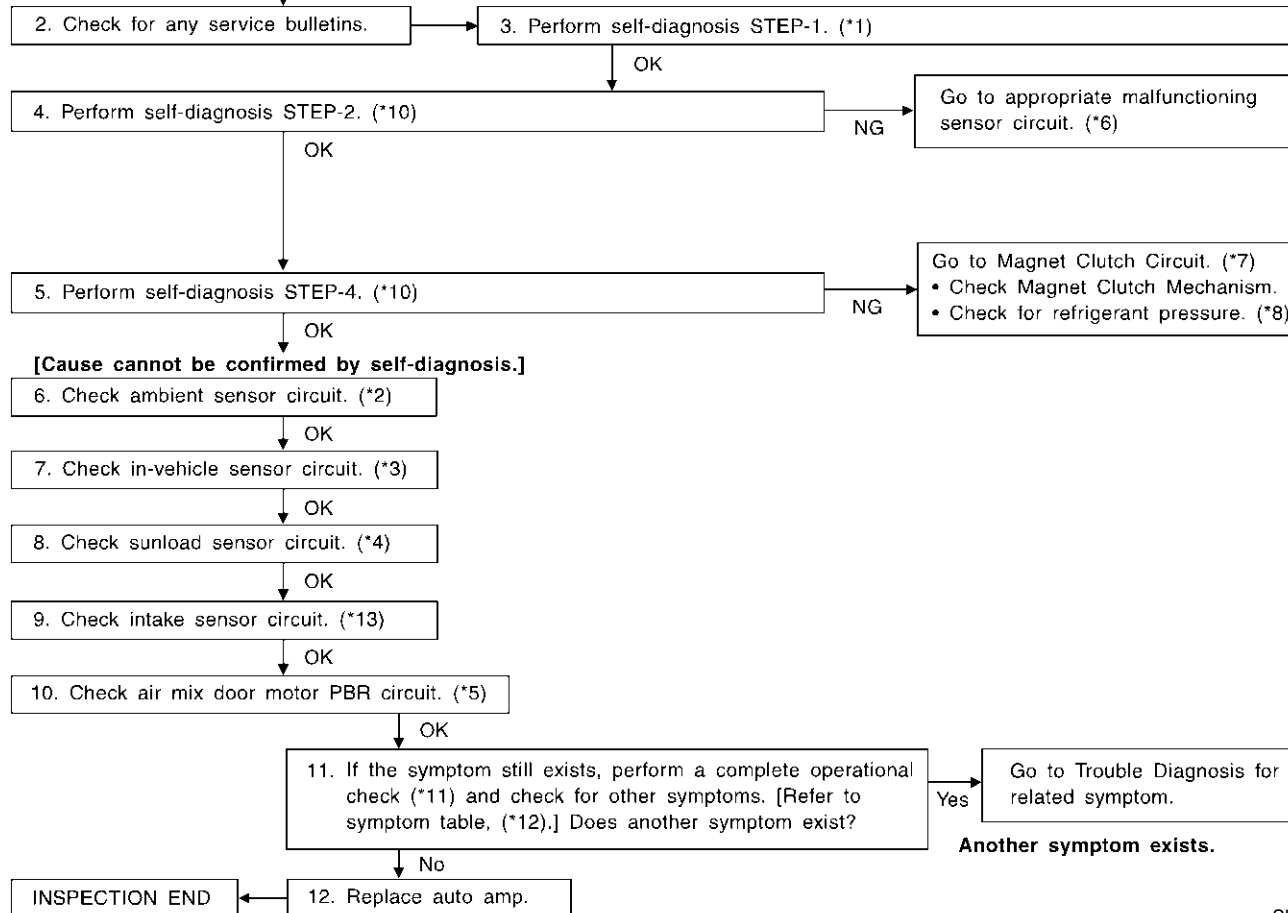

MT

AT

AX

SU

BR

ST

RS

BT

HA

SC

SHA775F

EL

*1: FUNCTION CONFIRMATION PROCEDURE (HA-44)

*2: HA-124

*3: HA-127

*4: HA-130

*5: HA-136

*6: FUNCTION CONFIRMATION PROCEDURE (HA-44), see No. 13.

*7: HA-103

*8: HA-112

*9: HA-65

*10: HA-44

*11: HA-65

*12: HA-64

*13: HA-134

IDX

1. Confirm symptom by performing operational check.

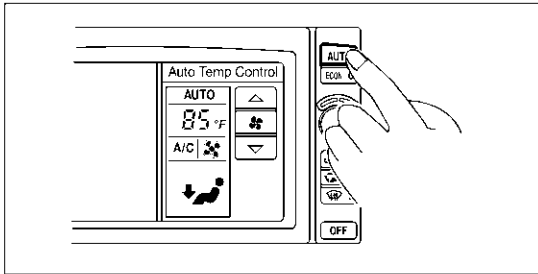

OPERATIONAL CHECK – AUTO mode

- a. Press AUTO switch.
- b. Display should indicate AUTO (not ECON). Confirm that the compressor clutch engages (audio or visual inspection). (Discharge air and blower speed will depend on ambient, in-vehicle and set temperatures.)

**If OK (symptom cannot be duplicated), perform complete operational check (*9).
If NG (symptom is confirmed), continue with STEP-2 following.**

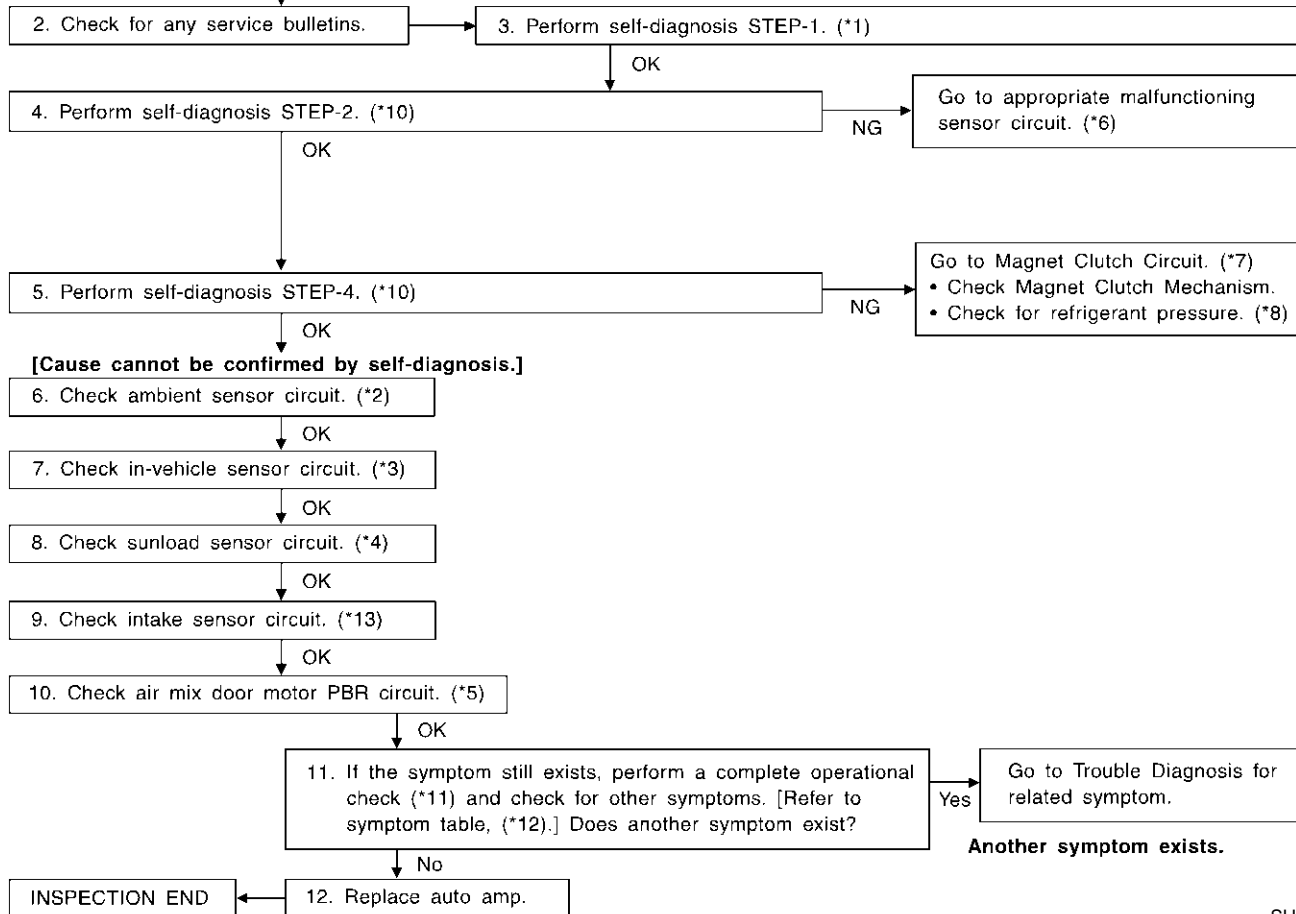

*1: FUNCTION CONFIRMATION PROCEDURE (HA-54)
*2: HA-124
*3: HA-127
*4: HA-130
*5: HA-136

*6: FUNCTION CONFIRMATION PROCEDURE (HA-54), see No. 14.
*7: HA-103
*8: HA-112
*9: HA-67

*10: HA-54
*11: HA-67
*12: HA-64
*13: HA-134

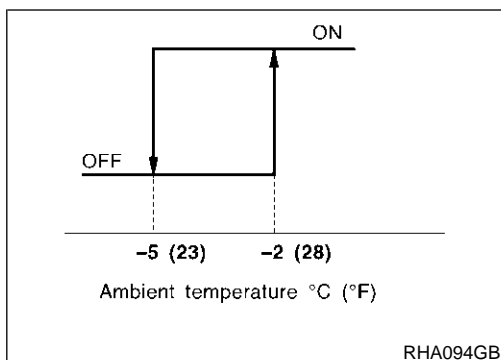

SYSTEM DESCRIPTION

Auto amplifier controls compressor operation by ambient temperature and signal from ECM. =NFHA0202

Low Temperature Protection Control

Auto amplifier will turn the compressor "ON" or "OFF" as determined by a signal detected by ambient sensor. NFHA0202S01
 When ambient temperatures are greater than -2°C (28°F), the compressor turns "ON". The compressor turns "OFF" when ambient temperatures are less than -5°C (23°F).

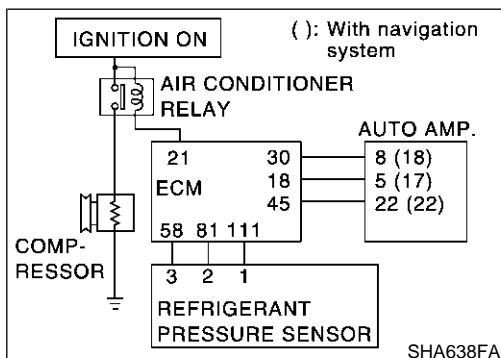

DIAGNOSTIC PROCEDURE

SYMPTOM: Magnet clutch does not engage when **AUTO** switch is ON. NFHA0203

1	CHECK POWER SUPPLY FOR COMPRESSOR	<p>Disconnect compressor harness connector. Do approx. 12 volts exist between compressor harness connector terminal No. 1 and ground?</p> <div style="text-align: center;"> <p>Compressor connector (A3)</p> </div> <p style="text-align: right;">RHA096GE</p> <p style="text-align: center;">Yes or No</p>
Yes	▶	<p>Check magnet clutch coil.</p> <ol style="list-style-type: none"> 1. If NG, replace magnet clutch. Refer to HA-144. 2. Go to "FUNCTION CONFIRMATION PROCEDURE", "Self-diagnosis", HA-44; Without Navigation System or HA-54; With Navigation System and perform self-diagnosis STEP-4. Confirm that magnet clutch operation is normal.
No	▶	<p>Disconnect A/C relay. And GO TO 2.</p>

GI
MA
EM
LC
EC
FE
CL
MT
AT
AX
SU
BR
ST
RS
BT
HA
SC
EL
IDX

2	CHECK CIRCUIT CONTINUITY BETWEEN A/C RELAY AND COMPRESSOR	
Check circuit continuity between A/C relay harness connector terminal No. 3 and compressor harness connector terminal No. 1.		
<p>Continuity should exist. If OK, check harness for short.</p> <p style="text-align: center;">OK or NG</p>		
OK	▶	GO TO 3.
NG	▶	Repair harness or connector.

RHA400HA

3	CHECK POWER SUPPLY FOR A/C RELAY	
Disconnect A/C relay. Do approx. 12 volts exist between A/C relay harness connector terminal Nos. 1, 5 and ground?		
<p style="text-align: center;">Yes or No</p>		
Yes	▶	GO TO 4.
No	▶	Check power supply circuit and 10A [Nos. 28 located in fuse block (J/B)], and 66 located in fuse and fusible link box) fuse at fuse block. Refer to EL-12, "Wiring Diagram — POWER —". <ul style="list-style-type: none"> ● If OK, check for open circuit in wiring harness. Repair or replace as necessary. ● If NG, replace fuse and check wiring harness for short circuit. Repair or replace as necessary.

RHA401H

4	CHECK A/C RELAY AFTER DISCONNECTING IT	
Refer to HA-107.		
OK or NG		
OK	▶	Reconnect A/C relay. And GO TO 5.
NG	▶	1. Replace A/C relay. 2. Go to "FUNCTION CONFIRMATION PROCEDURE", "Self-diagnosis", HA-44; Without Navigation System or HA-54; With Navigation System and perform self-diagnosis STEP-4. Confirm that magnet clutch operation is normal.

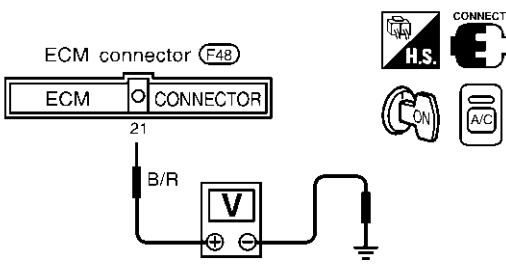
5	CHECK COIL SIDE CIRCUIT OF A/C RELAY	
Do approx. 12 volts exist between ECM harness connector terminal No. 21 and ground?		
		
RHA0811		
Yes or No		
Yes	▶	GO TO 6.
No	▶	Disconnect A/C relay. Disconnect ECM harness connector. GO TO 9.

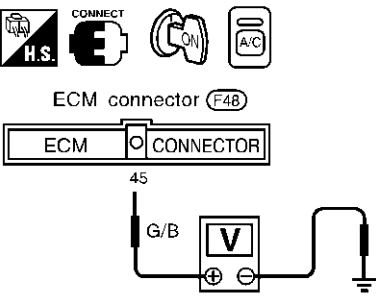
6	CHECK VOLTAGE FOR ECM	
Do approx. 4.6 volts exist between ECM harness connector terminal No. 45 and ground?		
		
RHA701FM		
Yes or No		
Yes	▶	GO TO 7.
No	▶	Check ECM. Refer to EC-140, "ECM Terminals and Reference Value".

GI
 MA
 EM
 LC
 EC
 FE
 CL
 MT
 AT
 AX
 SU
 BR
 ST
 RS
 BT
 HA
 SC
 EL
 IDX

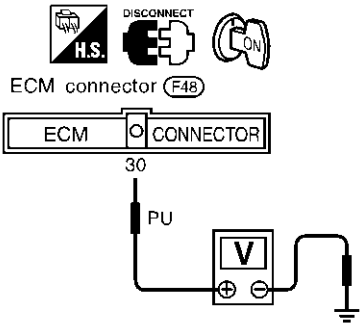
7	CHECK REFRIGERANT PRESSURE SENSOR INPUT SIGNAL	
Do approx. 4.6 volts exist between ECM harness connector terminal No. 30 and ground?		
		
SHA639F		
Yes or No		
Yes	▶	GO TO 8.
No	▶	1. Repair harness or connector. 2. Go to "FUNCTION CONFIRMATION PROCEDURE", "Self-diagnosis", HA-44; Without Navigation System or HA-54; With Navigation System and perform self-diagnosis STEP-4. Confirm that magnet clutch operation is normal.

8	CHECK REFRIGERANT PRESSURE SENSOR	
Refer to HA-107.		
OK or NG		
OK	▶	GO TO 9.
NG	▶	Replace refrigerant pressure sensor.

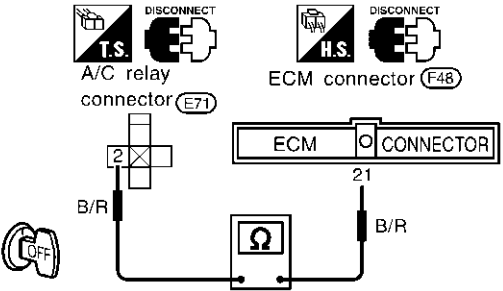
9	CHECK CIRCUIT CONTINUITY BETWEEN A/C RELAY AND ECM	
Check circuit continuity between A/C relay harness connector terminal No. 2 and ECM harness connector terminal No. 21.		
		
RHA082I		
<p style="color: blue;">Continuity should exist.</p> If OK, check harness for short.		
OK or NG		
OK	▶	Check ECM. Refer to EC-140, "ECM Terminals and Reference Value".
NG	▶	Repair harness or connector. Replace auto amp.

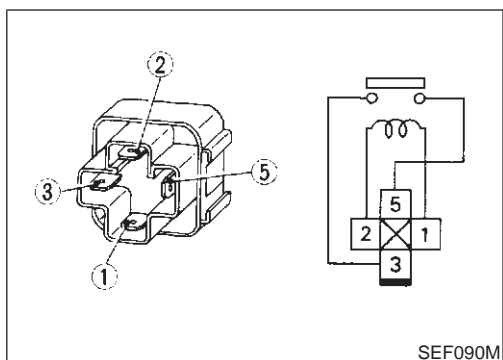

COMPONENT INSPECTION

A/C Relay

NFHA0204

NFHA0204S01

Check continuity between terminal Nos. 3 and 5.

Conditions	Continuity
12V direct current supply between terminal Nos. 1 and 2	Yes
No current supply	No

If NG, replace relay.

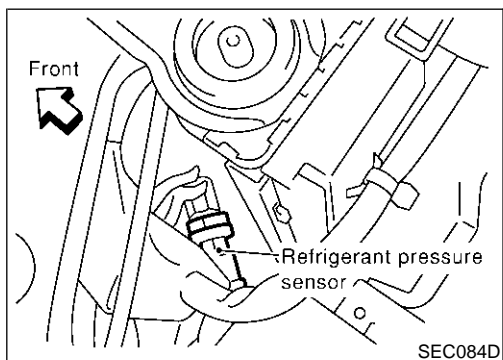

Refrigerant Pressure Sensor

NFHA0204S02

The refrigerant pressure sensor is located on the condenser.

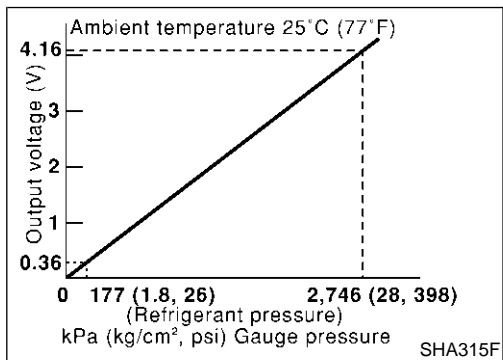
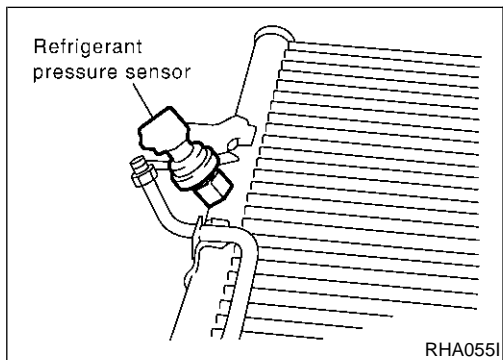

Make sure that higher A/C refrigerant pressure results in higher refrigerant-pressure sensor output voltage. Refer to EC-716, "Diagnostic Procedure".

GI

MA

EM

LC

EC

FE

CL

MT

AT

AX

SU

BR

ST

RS

BT

HA

SC

EL

IDX

Insufficient Cooling

TROUBLE DIAGNOSIS PROCEDURE FOR INSUFFICIENT COOLING

=NFHA0205

SYMPTOM:

- Insufficient cooling

Inspection Flow

Without Navigation System

NFHA0205S01

NFHA0205S0101

1. Confirm symptom by performing the following operational check.

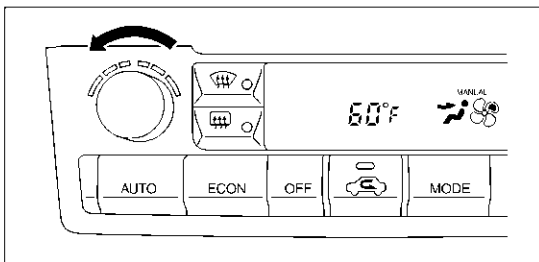

OPERATIONAL CHECK – Temperature decrease

- Turn the temperature dial counterclockwise until 18°C (60°F) is displayed.
- Check for cold air at discharge air outlets.

If OK (symptom cannot be duplicated), perform complete operational check (*10).
If NG (symptom is confirmed), continue with STEP-2 following.

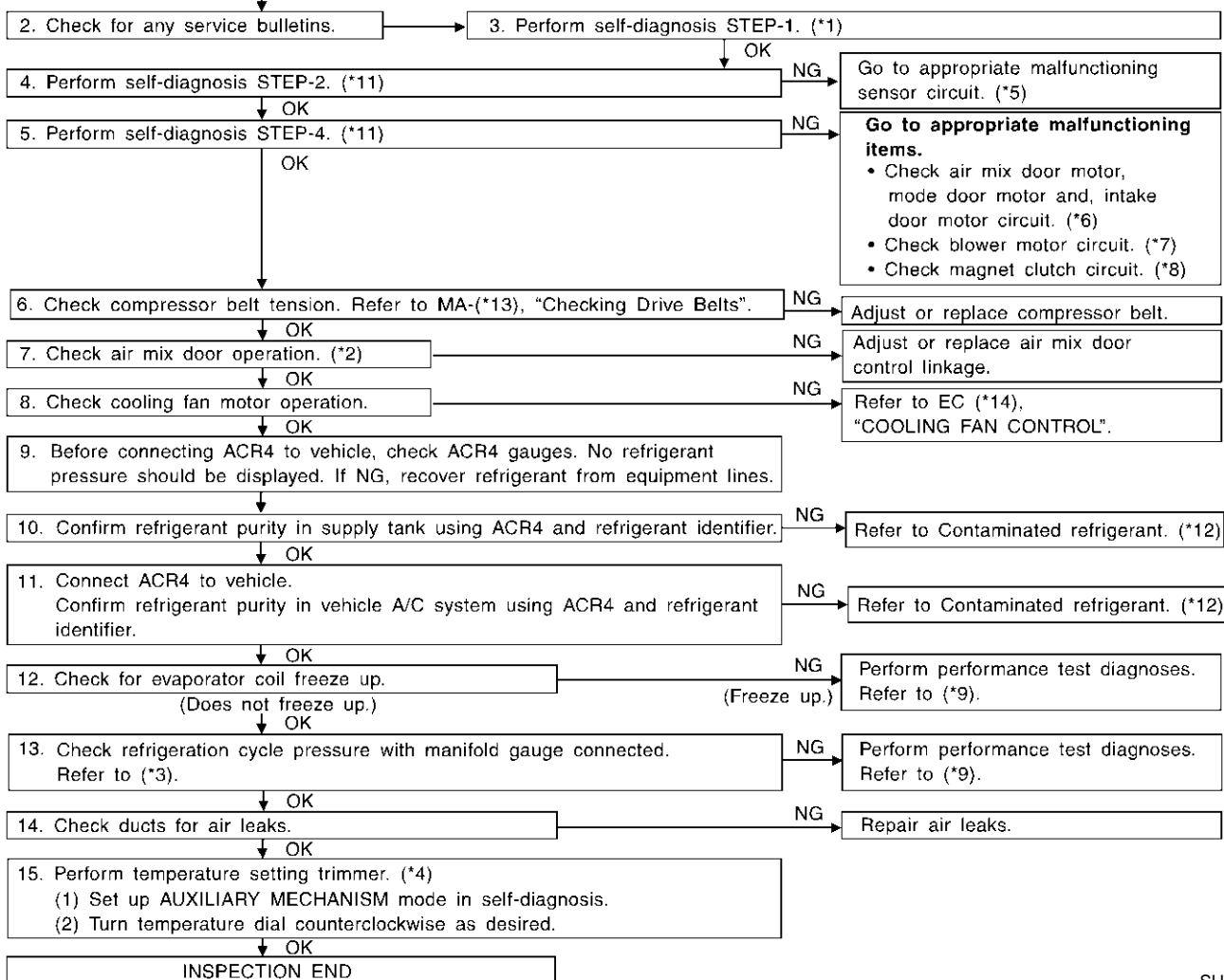

SHA777F

*1: HA-43

*2: HA-86

*3: HA-112

*4: HA-52

*5: FUNCTION CONFIRMATION PROCEDURE (HA-44), see No. 13.

*6: HA-77

*7: HA-93

*8: HA-103

*9: HA-110

*10: HA-65

*11: HA-44

*12: HA-3

*13: MA-13

*14: EC-515

With Navigation System

NFHA0205S0102

1. Confirm symptom by performing the following operational check.

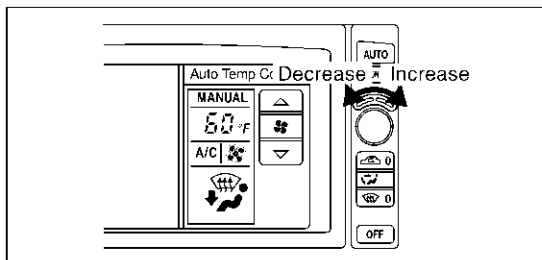

OPERATIONAL CHECK – Temperature decrease

- a. Turn the temperature dial counterclockwise until 18°C (60°F) is displayed.
- b. Check for cold air at discharge air outlets.

If OK (symptom cannot be duplicated), perform complete operational check (*10).
If NG (symptom is confirmed), continue with STEP-2 following.

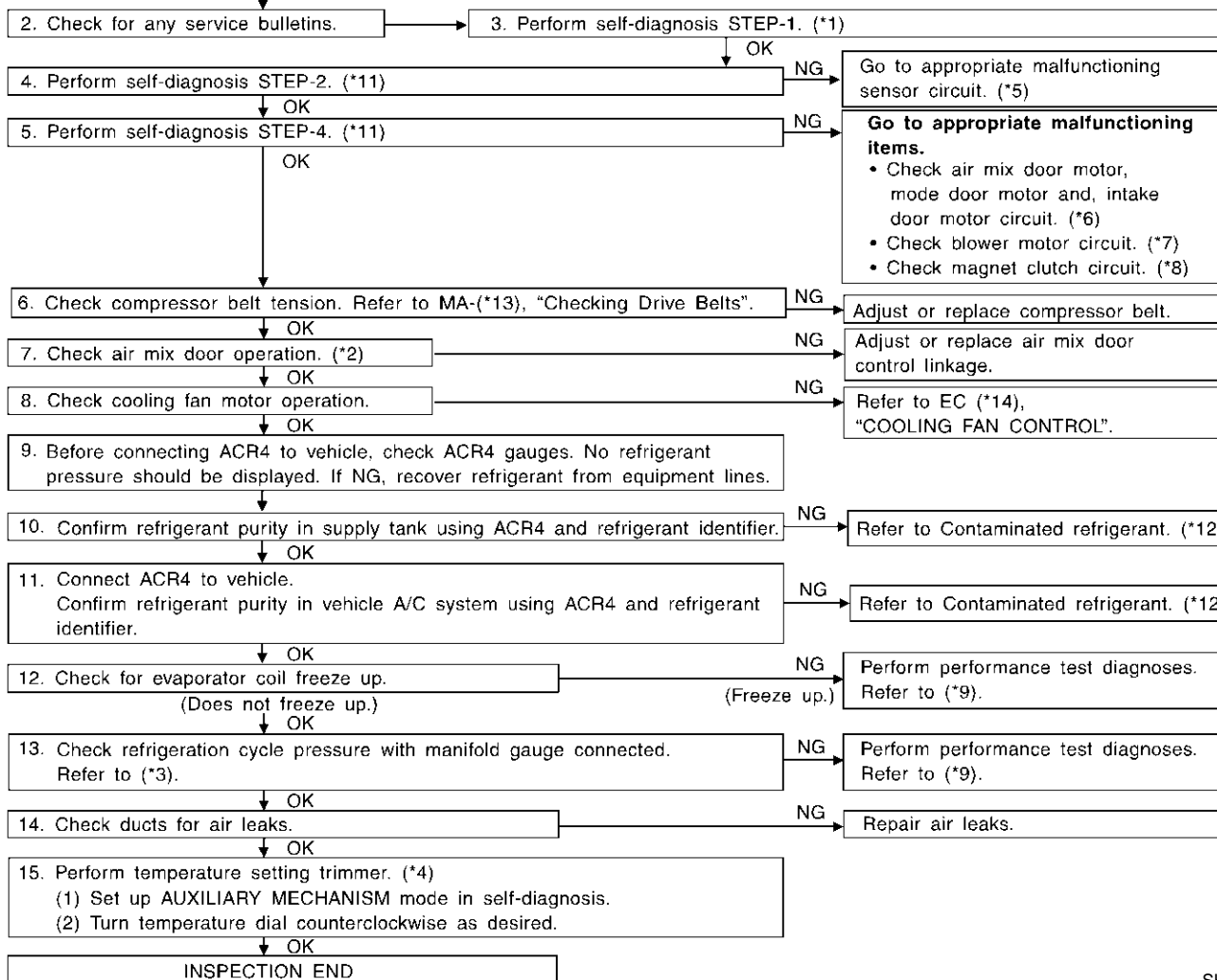

SHA778F

*1: HA-53

*2: HA-86

*3: HA-112

*4: HA-63

*5: FUNCTION CONFIRMATION PROCEDURE (HA-54), see No. 14.

*6: HA-77

*7: HA-93

*8: HA-103

*9: HA-110

*10: HA-67

*11: HA-54

*12: HA-3

*13: MA-13

*14: EC-515

GI

MA

EM

LC

EC

FE

CL

MT

AT

AX

SU

BR

ST

RS

BT

HA

SC

EL

IDX

PERFORMANCE TEST DIAGNOSES

NFHA0206

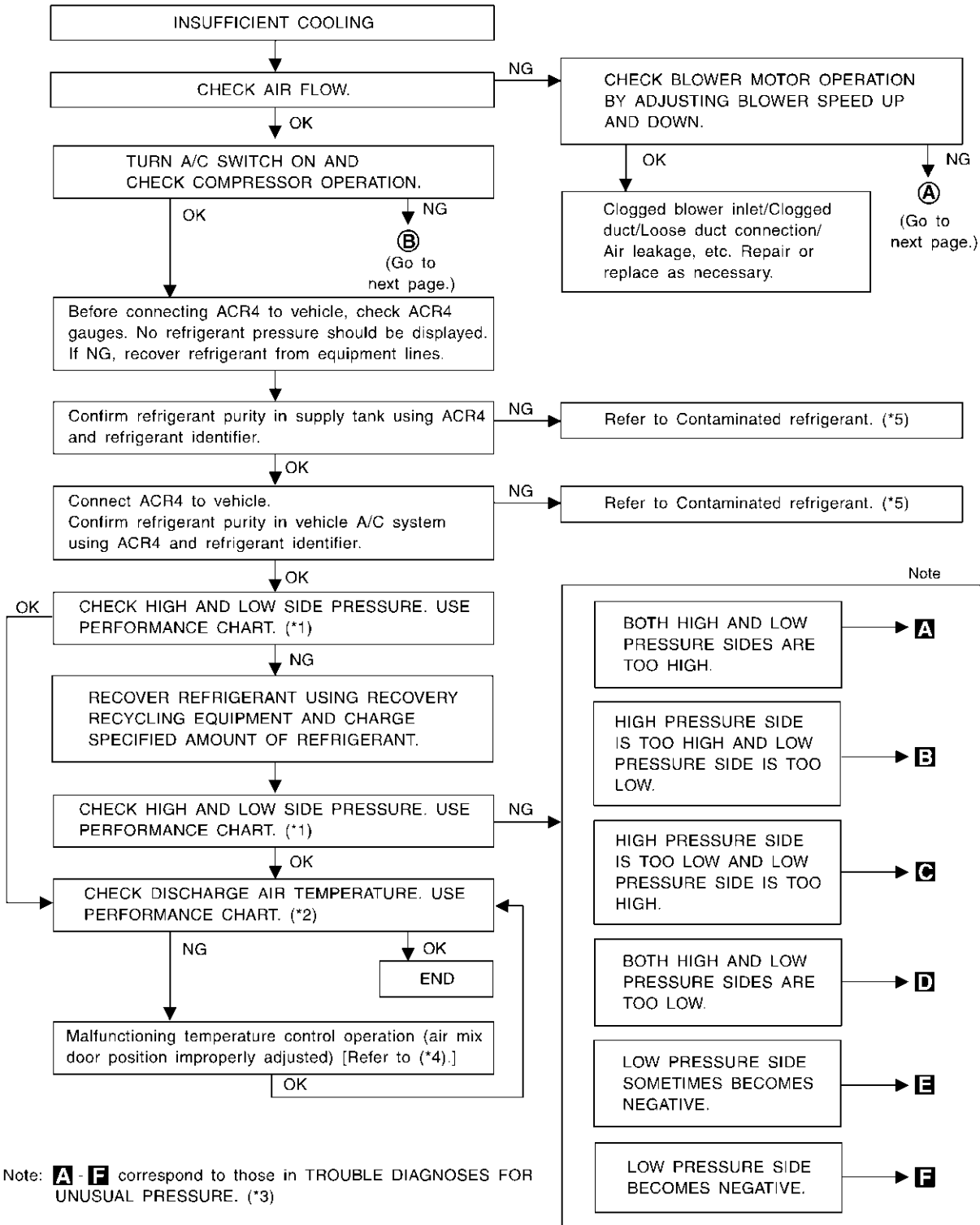

SHA333FA

*1: HA-112

*3: HA-113

*5: HA-3

*2: HA-112

*4: HA-85

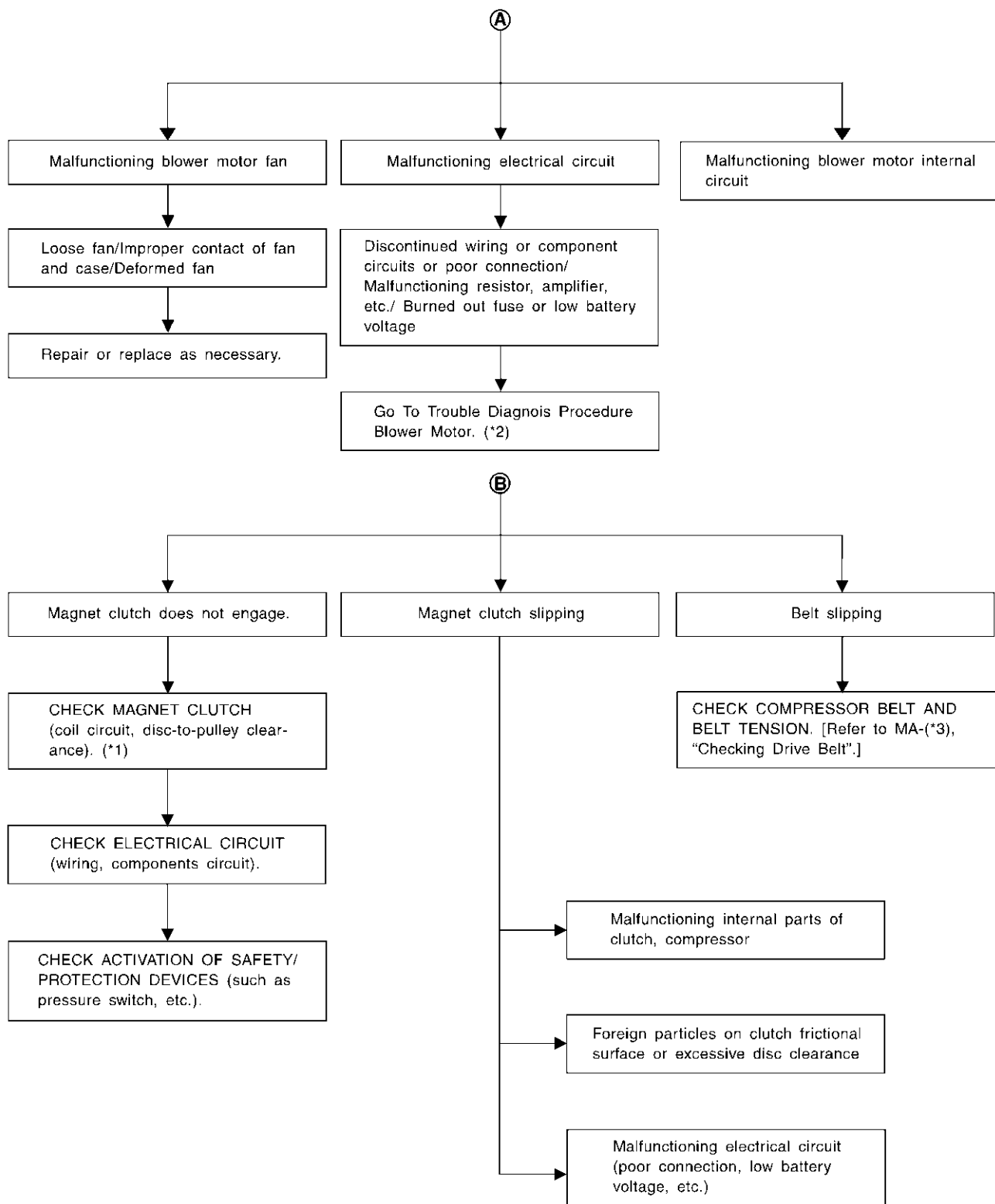

GI

MA

EM

LC

EC

FE

CL

MT

AT

AX

SU

BR

ST

RS

BT

HA

SC

SHA329F

EL

*1: HA-144

*2: HA-91

*3: MA-13

IDX

Insufficient Cooling (Cont'd)

PERFORMANCE TEST

NFHA0207

Test Condition

NFHA0207S01

Testing must be performed as follows:

Vehicle location	Indoors or in the shade (in a well-ventilated place)
Doors	Closed
Door windows	Open
Hood	Open
TEMP.	Max. COLD
Mode switch	(Ventilation) set
REC switch	(Recirculation) set
(blower) speed	Max. speed set
Engine speed	Idle speed

Operate the air conditioning system for 10 minutes before taking measurements.

Test Reading

NFHA0207S02

Recirculating-to-discharge Air Temperature Table

NFHA0207S0201

Inside air (Recirculating air) at blower assembly inlet		Discharge air temperature at center ventilator °C (°F)
Relative humidity %	Air temperature °C (°F)	
50 - 60	15 (59)	3.5 - 5.4 (38 - 42)
	20 (68)	6.6 - 8.9 (44 - 48)
	25 (77)	9.5 - 12.6 (49 - 55)
	30 (86)	13.4 - 16.5 (56 - 62)
	35 (95)	17.6 - 21.3 (64 - 70)
60 - 70	15 (59)	5.4 - 7.1 (42 - 45)
	20 (68)	8.9 - 11.0 (48 - 52)
	25 (77)	12.6 - 15.4 (55 - 60)
	30 (86)	16.5 - 20.0 (62 - 68)
	35 (95)	21.3 - 24.8 (70 - 77)

Ambient Air Temperature-to-operating Pressure Table

NFHA0207S0202

Ambient air		High-pressure (Discharge side) kPa (kg/cm ² , psi)	Low-pressure (Suction side) kPa (kg/cm ² , psi)
Relative humidity %	Air temperature °C (°F)		
50 - 70	15 (59)	539 - 657 (5.5 - 6.7, 78 - 95)	167 - 206 (1.7 - 2.1, 24 - 30)
	20 (68)	677 - 824 (6.9 - 8.4, 98 - 119)	177 - 216 (1.8 - 2.2, 26 - 31)
	25 (77)	843 - 1,030 (8.6 - 10.5, 122 - 149)	177 - 226 (1.8 - 2.3, 26 - 33)
	30 (86)	1,030 - 1,275 (10.5 - 13.0, 149 - 185)	216 - 255 (2.2 - 2.6, 31 - 37)
	35 (95)	1,245 - 1,520 (12.7 - 15.5, 181 - 220)	265 - 324 (2.7 - 3.3, 38 - 47)

TROUBLE DIAGNOSES FOR UNUSUAL PRESSURE

NFHA0208

Whenever system's high and/or low side pressure is unusual, diagnose using a manifold gauge. The marker above the gauge scale in the following tables indicates the standard (normal) pressure range. Since the standard (normal) pressure, however, differs from vehicle to vehicle, refer to HA-112 ("Ambient air temperature-to-operating pressure table").

Both High and Low-pressure Sides are Too High.

NFHA0208S01

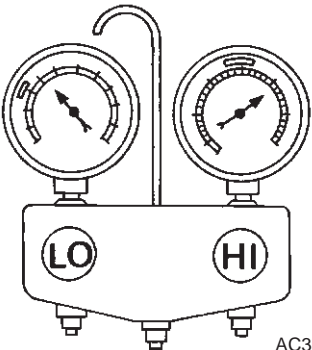
Gauge indication	Refrigerant cycle	Probable cause	Corrective action
<p>Both high and low-pressure sides are too high.</p> <p>A</p>  <p style="text-align: right;">AC359A</p>	<ul style="list-style-type: none"> Pressure is reduced soon after water is splashed on condenser. 	<p>Excessive refrigerant charge in refrigeration cycle</p>	<p>Reduce refrigerant until specified pressure is obtained.</p>
	<p>Air suction by cooling fan is insufficient.</p>	<p>Insufficient condenser cooling performance</p> <p style="text-align: center;">↓</p> <ol style="list-style-type: none"> Condenser fins are clogged. Improper fan rotation of cooling fan 	<ul style="list-style-type: none"> Clean condenser. Check and repair cooling fan as necessary.
	<ul style="list-style-type: none"> Low-pressure pipe is not cold. When compressor is stopped high-pressure value quickly drops by approximately 196 kPa (2 kg/cm², 28 psi). It then decreases gradually thereafter. 	<p>Poor heat exchange in condenser (After compressor operation stops, high pressure decreases too slowly.)</p> <p style="text-align: center;">↓</p> <p>Air in refrigeration cycle</p>	<p>Evacuate repeatedly and recharge system.</p>
	<p>Engine tends to overheat.</p>	<p>Engine cooling systems malfunction.</p>	<p>Check and repair each engine cooling system.</p>
	<ul style="list-style-type: none"> An area of the low-pressure pipe is colder than areas near the evaporator outlet. Plates are sometimes covered with frost. 	<ul style="list-style-type: none"> Excessive liquid refrigerant on low-pressure side Excessive refrigerant discharge flow Expansion valve is open a little compared with the specification. <p style="text-align: center;">↓</p> <ol style="list-style-type: none"> Improper expansion valve installation Improper expansion valve adjustment 	<p>Replace expansion valve.</p>

GI
 MA
 EM
 LC
 EC
 FE
 CL
 MT
 AT
 AX
 SU
 BR
 ST
 RS
 BT
 HA
 SC
 EL
 IDX

High-pressure Side is Too High and Low-pressure Side is Too Low.

NFHA0208S02

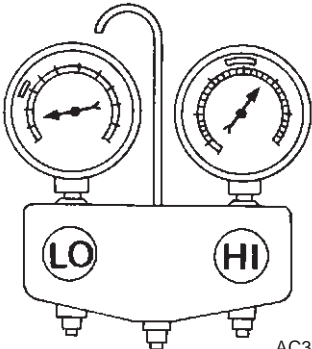
Gauge indication	Refrigerant cycle	Probable cause	Corrective action
High-pressure side is too high and low-pressure side is too low. B  <p style="text-align: right; margin-right: 50px;">AC360A</p>	Upper side of condenser and high-pressure side are hot, however, liquid tank is not so hot.	High-pressure tube or parts located between compressor and condenser are clogged or crushed.	<ul style="list-style-type: none"> ● Check and repair or replace malfunctioning parts. ● Check lubricant for contamination.

High-pressure Side is Too Low and Low-pressure Side is Too High.

NFHA0208S03

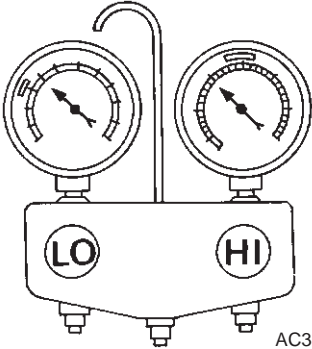
Gauge indication	Refrigerant cycle	Probable cause	Corrective action
High-pressure side is too low and low-pressure side is too high. C  <p style="text-align: right; margin-right: 50px;">AC356A</p>	High and low-pressure sides become equal soon after compressor operation stops.	Compressor pressure operation is improper. ↓ Damaged inside compressor packings.	Replace compressor.
(Same gauge diagram as above)	No temperature difference between high and low-pressure sides	Compressor pressure operation is improper. ↓ Damaged inside compressor packings.	Replace compressor.

Both High- and Low-pressure Sides are Too Low.

NFHA0208S04

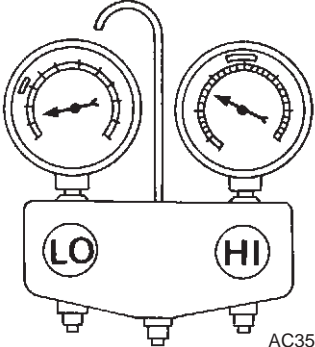
Gauge indication	Refrigerant cycle	Probable cause	Corrective action
<p>Both high- and low-pressure sides are too low.</p> <p>D</p>  <p style="text-align: right; margin-right: 20px;">AC353A</p>	<ul style="list-style-type: none"> There is a big temperature difference between receiver drier outlet and inlet. Outlet temperature is extremely low. Liquid tank inlet and expansion valve are frosted. 	<p>Compressor discharge capacity does not change. (Compressor stroke is set at maximum.)</p>	<ul style="list-style-type: none"> Replace liquid tank. Check lubricant for contamination.
	<ul style="list-style-type: none"> Temperature of expansion valve inlet is extremely low as compared with areas near liquid tank. Expansion valve inlet may be frosted. Temperature difference occurs somewhere in high-pressure side 	<p>High-pressure pipe located between receiver drier and expansion valve is clogged.</p>	<ul style="list-style-type: none"> Check and repair malfunctioning parts. Check lubricant for contamination.
	<ul style="list-style-type: none"> Expansion valve and liquid tank are warm or only cool when touched. 	<p>Low refrigerant charge</p> <p style="text-align: center;">↓</p> <p>Leaking fittings or components</p>	<p>Check refrigerant for leaks. Refer to "Checking Refrigerant Leaks", HA-151.</p>
	<p>There is a big temperature difference between expansion valve inlet and outlet while the valve itself is frosted.</p>	<p>Expansion valve closes a little compared with the specification.</p> <p style="text-align: center;">↓</p> <ol style="list-style-type: none"> Improper expansion valve adjustment Malfunctioning expansion valve Outlet and inlet may be clogged. 	<ul style="list-style-type: none"> Remove foreign particles by using compressed air. Check lubricant for contamination.
	<p>An area of the low-pressure pipe is colder than areas near the evaporator outlet.</p>	<p>Low-pressure pipe is clogged or crushed.</p>	<ul style="list-style-type: none"> Check and repair malfunctioning parts. Check lubricant for contamination.
	<p>Air flow volume is not enough or is too low.</p>	<p>Evaporator is frozen.</p> <p style="text-align: center;">↓</p> <p>Compressor discharge capacity does not change. (Compressor stroke is set at maximum length.)</p>	<p>Replace compressor.</p>

GI

MA

EM

LC

EC

FE

CL

MT

AT

AX

SU

BR

ST

RS

BT

HA

SC

EL

IDX

Low-pressure Side Sometimes Becomes Negative.

NFHA0208S05

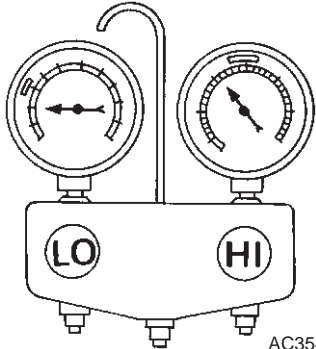
Gauge indication	Refrigerant cycle	Probable cause	Corrective action
Low-pressure side sometimes becomes negative. E 	<ul style="list-style-type: none"> ● Air conditioning system does not function and does not cyclically cool the compartment air. ● The system constantly functions for a certain period of time after compressor is stopped and restarted. 	Refrigerant does not discharge cyclically. ↓ Moisture is frozen at expansion valve outlet and inlet. ↓ Water is mixed with refrigerant.	<ul style="list-style-type: none"> ● Drain water from refrigerant or replace refrigerant. ● Replace liquid tank.

Low-pressure Side Becomes Negative.

NFHA0208S06

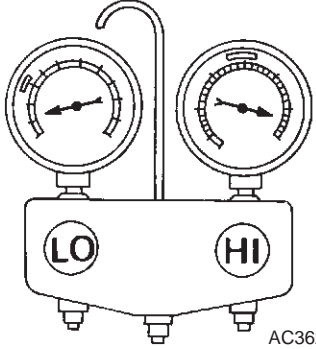
Gauge indication	Refrigerant cycle	Probable cause	Corrective action
Low-pressure side becomes negative. F 	Liquid tank or front/rear side of expansion valve's pipe is frosted or dewed.	High-pressure side is closed and refrigerant does not flow. ↓ Expansion valve or liquid tank is frosted.	Leave the system at rest until no frost is present. Start it again to check whether or not the problem is caused by water or foreign particles. <ul style="list-style-type: none"> ● If water is the cause, initially cooling is okay. Then the water freezes causing a blockage. Drain water from refrigerant or replace refrigerant. ● If due to foreign particles, remove expansion valve and remove the particles with dry and compressed air (not shop air). ● If either of the above methods cannot correct the problem, replace expansion valve. ● Replace liquid tank. ● Check lubricant for contamination.

Insufficient Heating

TROUBLE DIAGNOSIS PROCEDURE FOR INSUFFICIENT HEATING

SYMPTOM: Insufficient heating

=NFHA0209

Inspection Flow

Without Navigation System

NFHA0209S01

NFHA0209S0101

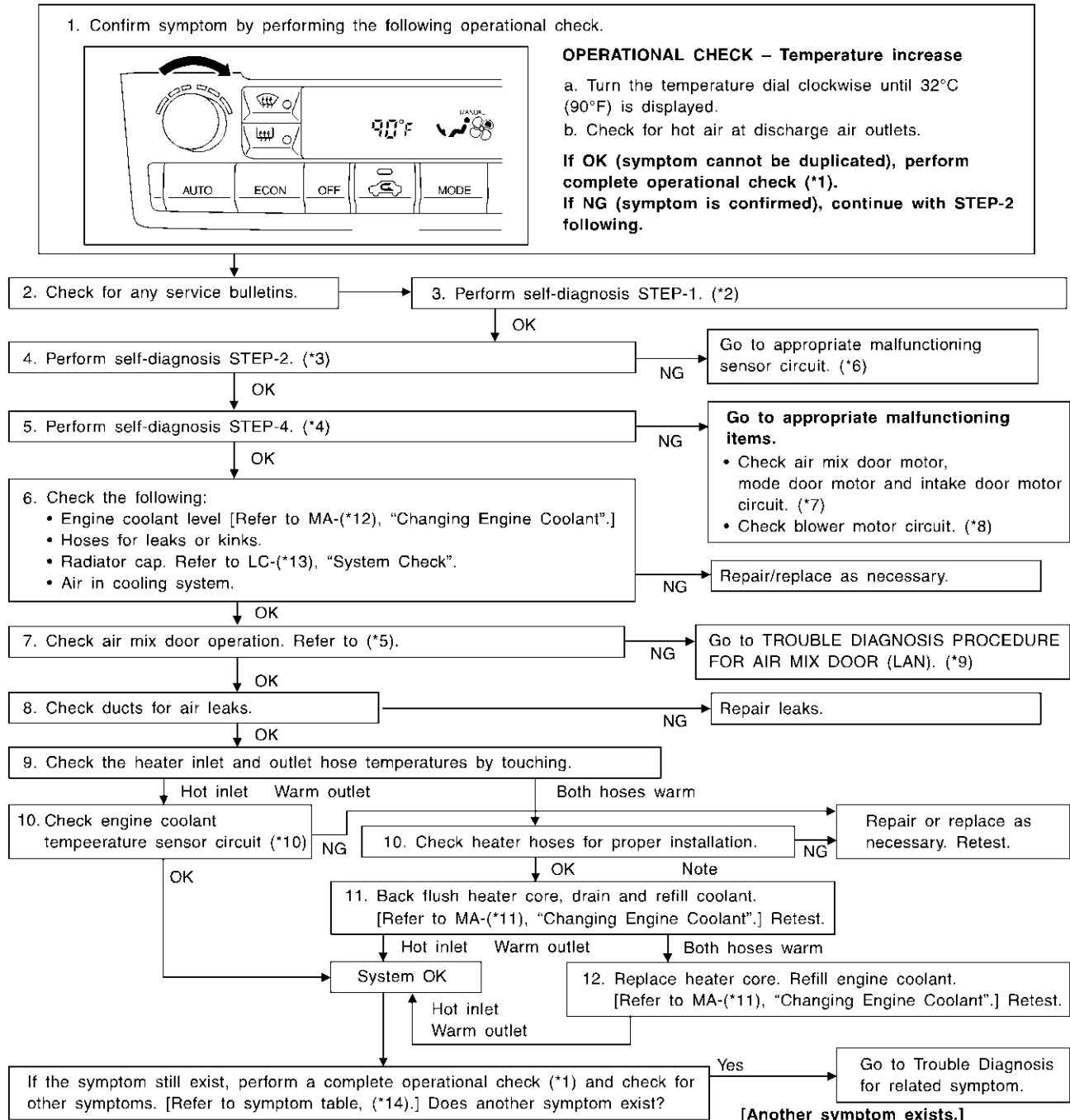

*1: HA-65

*2: HA-43

*3: HA-44

*4: HA-44

*5: HA-86

*6: FUNCTION CONFIRMATION PROCEDURE (HA-44), see No. 13.

*7: HA-78

*8: HA-94

*9: HA-83

*10: EC-224

*11: MA-14

*12: MA-14

*13: LC-12

*14: HA-64

SHA779F

1. Confirm symptom by performing the following operational check.

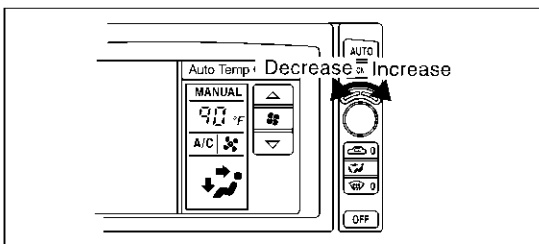

OPERATIONAL CHECK – Temperature increase

- a. Turn the temperature dial clockwise until 32°C (90°F) is displayed.
- b. Check for hot air at discharge air outlets.

If OK (symptom cannot be duplicated), perform complete operational check (*1).
If NG (symptom is confirmed), continue with STEP-2 following.

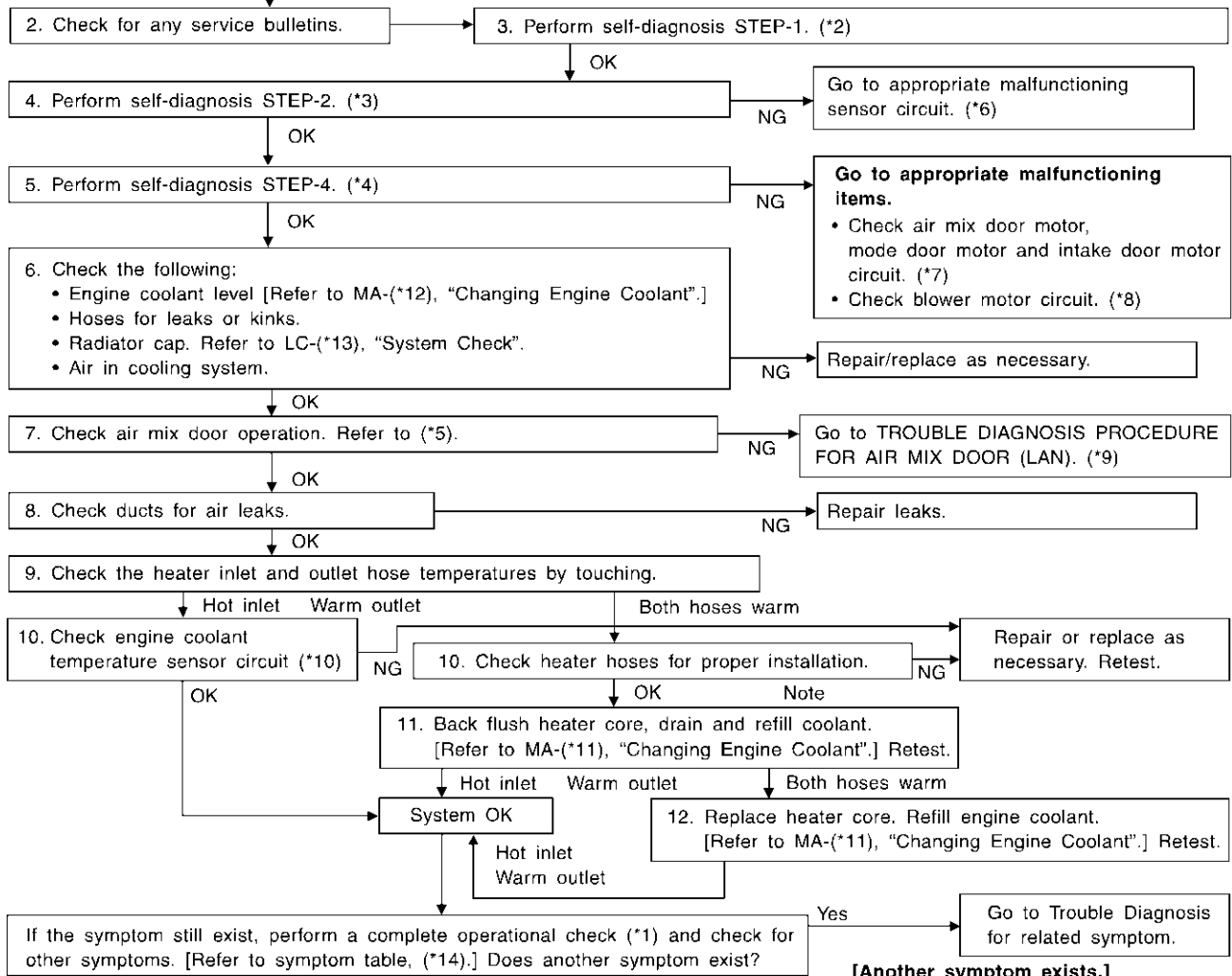

SHA780F

- | | | |
|--|-------------|------------|
| *1: HA-67 | *7: HA-78 | *11: MA-14 |
| *2: HA-53 | *8: HA-94 | *12: MA-14 |
| *3: HA-54 | *9: HA-83 | *13: LC-12 |
| *4: HA-54 | *10: EC-224 | *14: HA-64 |
| *5: HA-86 | | |
| *6: FUNCTION CONFIRMATION PROCEDURE (HA-54), see No. 14. | | |

Noise

TROUBLE DIAGNOSIS PROCEDURE FOR NOISE

SYMPTOM:

- Noise

INSPECTION FLOW

=NFHA0210

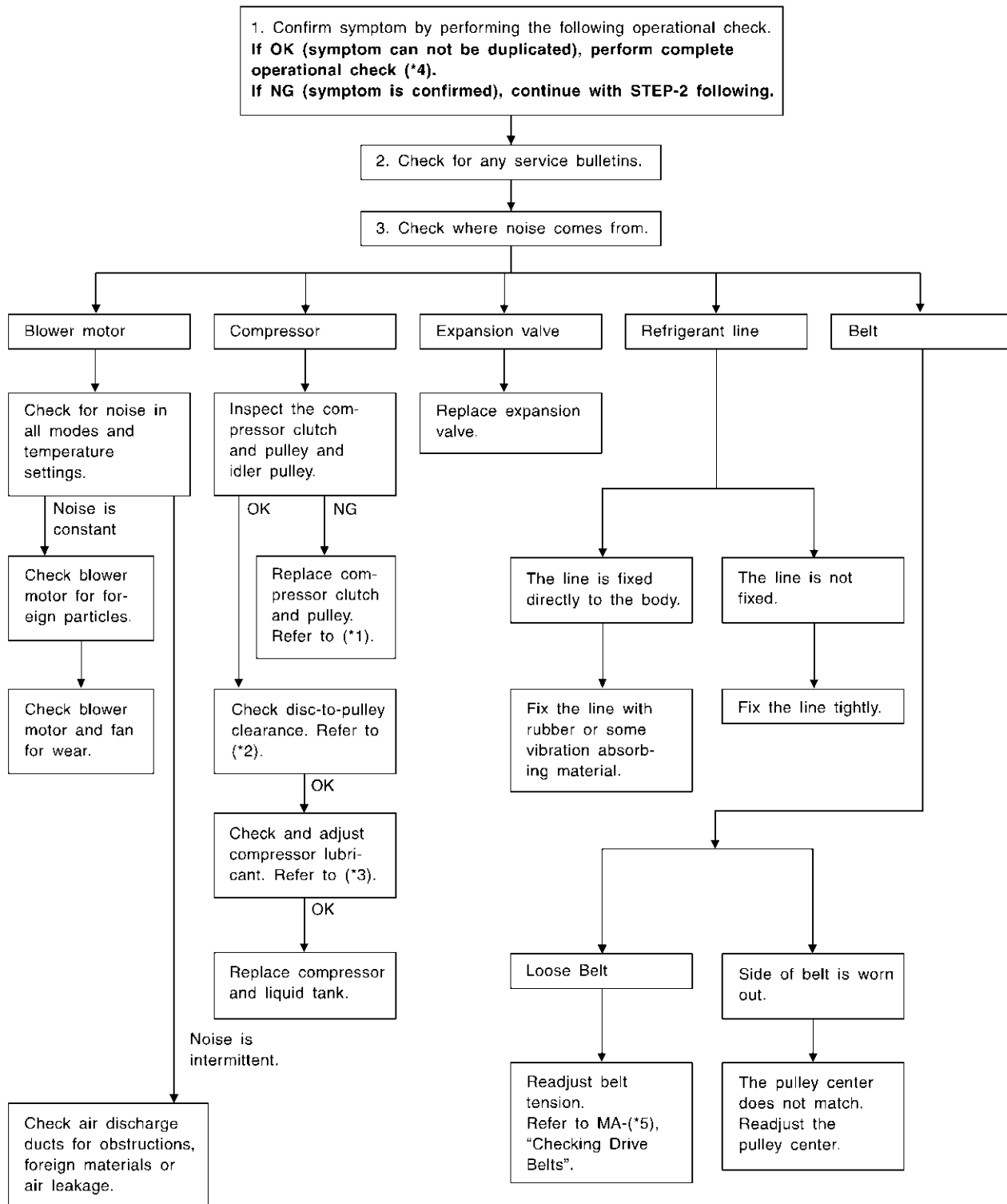

*1: HA-144

*2: HA-146

*3: HA-141

GI
 MA
 EM
 LC
 EC
 FE
 CL
 MT
 AT
 AX
 SU
 BR
 ST
 RS
 BT
HA
 SC
 EL
 IDX

TROUBLE DIAGNOSES

AUTO

Noise (Cont'd)

*4: HA-65

*5: MA-13

Self-diagnosis

TROUBLE DIAGNOSIS PROCEDURE FOR SELF-DIAGNOSIS

=NFHA0211

SYMPTOM:

- Self-diagnosis cannot be performed.

INSPECTION FLOW

1. Confirm system by performing operational check.

Without navigation system

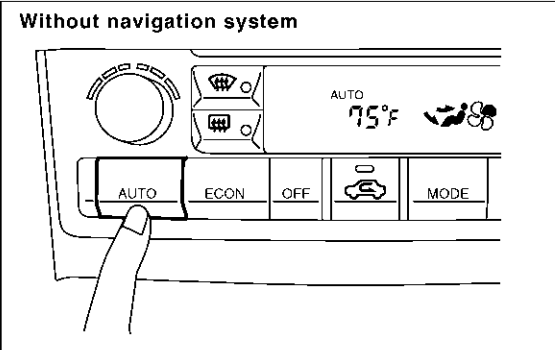

OPERATIONAL CHECK – AUTO mode

a. Press AUTO switch.
b. Display should indicate AUTO (not ECON).
Confirm that the compressor clutch engages (sound or visual inspection).
(Discharge air and blower speed will depend on ambient, in-vehicle and set temperatures.)

**If OK (symptom cannot be duplicated), perform complete operational check (*9).
If NG (symptom is confirmed), continue with STEP-2 following.**

With navigation system

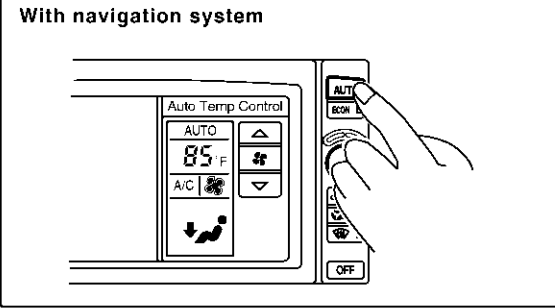

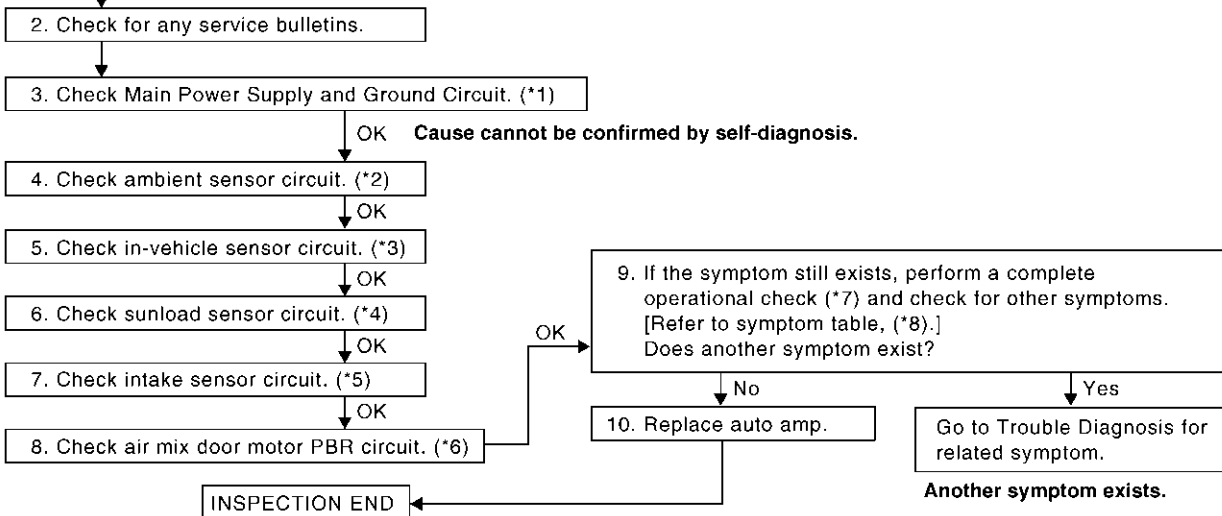

*1: HA-72
*2: HA-124
*3: HA-127

*4: HA-130
*5: HA-134
*6: HA-136

*7: HA-65
*8: HA-64
*9: HA-65

RHA0591A

GI
MA
EM
LC
EC
FE
CL
MT
AT
AX
SU
BR
ST
RS
BT
HA
SC
EL
IDX

Memory Function

TROUBLE DIAGNOSIS PROCEDURE FOR MEMORY FUNCTION

=NFHA0212

SYMPTOM:

- Memory function does not operate.

INSPECTION FLOW

1. Confirm symptom by performing the following operational check.

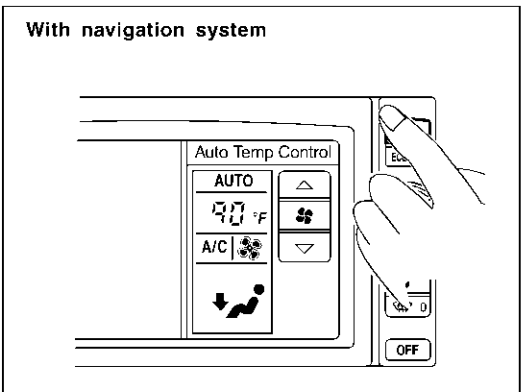
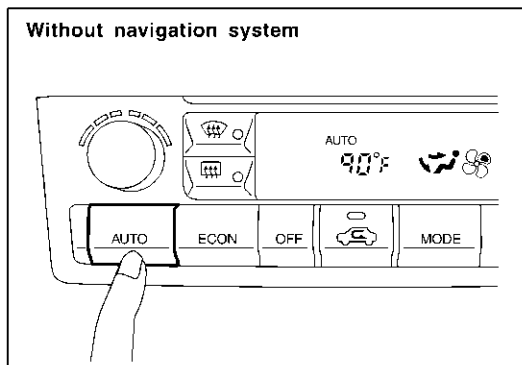

OPERATIONAL CHECK – Memory function

- a. Set the temperature 90°F or 32°C.
- b. Press OFF switch.
- c. Turn the ignition off.
- d. Turn the ignition on.
- e. Press the AUTO switch.
- f. Confirm that the set temperature remains at previous temperature.
- g. Press OFF switch.

If OK (symptom cannot be duplicated), perform complete operational check (*2).

If NG (symptom is confirmed), continue with STEP-2 following.

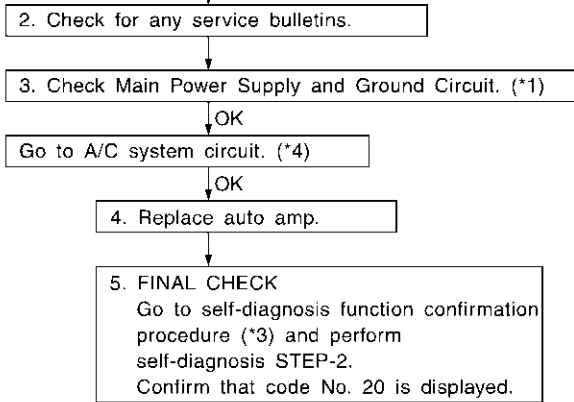

RHA0601A

*1: HA-72

*2: HA-65

*3: HA-44 (Without Navigation System)
HA-54 (With Navigation System)

*4: HA-72

ECON (ECONOMY) Mode

TROUBLE DIAGNOSIS PROCEDURE FOR ECON (ECONOMY) MODE

=NFHA0213

SYMPTOM:

- ECON mode does not operate.

INSPECTION FLOW

GI

MA

EM

LC

EC

FE

CL

MT

AT

AX

SU

BR

ST

RS

BT

HA

SC

EL

IDX

1. Confirm symptom by performing the following operational check.

Without navigation system

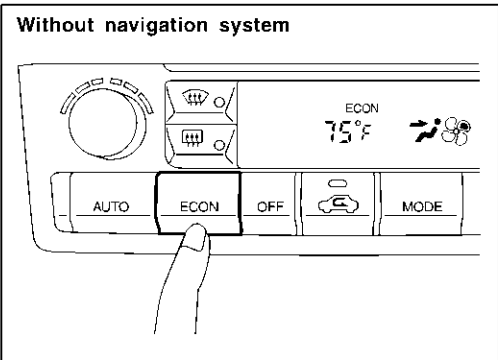

OPERATIONAL CHECK – ECON (ECONOMY) mode

- a. Set the temperature 75°F or 25°C.
- b. Press ECON switch.
- c. Display should indicate ECON (not AUTO).

Confirm that the compressor clutch is not engaged (visual inspection).
(Discharge air and blower speed will depend on ambient, in-vehicle, and set temperatures.)

If OK (symptom cannot be duplicated), perform complete operational check (*2).
If NG (symptom is confirmed), continue with STEP-2 following.

With navigation system

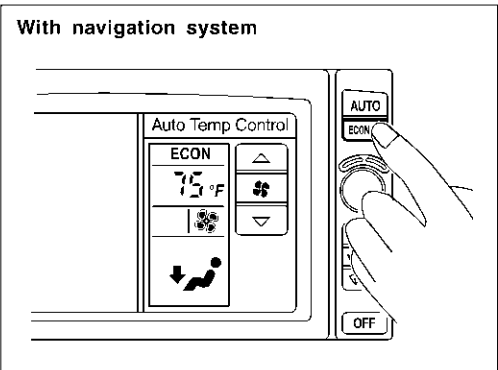

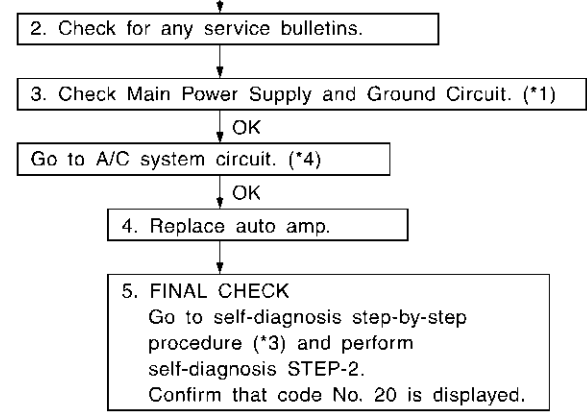

*1: HA-72

*2: HA-65

*3: HA-44 (Without Navigation System)
HA-54 (With Navigation System)

*4: HA-72

SHA624F

Ambient Sensor Circuit

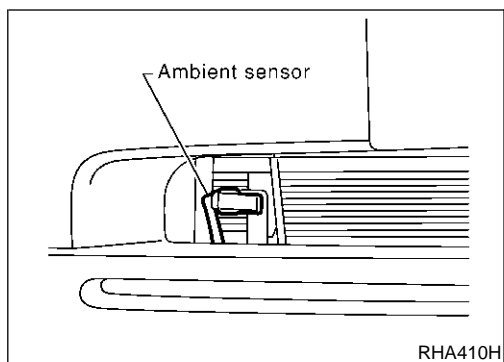

Ambient Sensor Circuit
COMPONENT DESCRIPTION

NFHA0214

The ambient sensor is attached in front of the right side condenser. It detects ambient temperature and converts it into a resistance value which is then input into the auto amplifier.

AMBIENT TEMPERATURE INPUT PROCESS

NFHA0215

The automatic amplifier includes a "processing circuit" for the ambient sensor input. However, when the temperature detected by the ambient sensor increases quickly, the processing circuit retards the auto amp. function. It only allows the auto amp. to recognize an ambient temperature increase of 0.33°C (0.6°F) per 100 seconds. As an example, consider stopping for a cup of coffee after high speed driving. Although the actual ambient temperature has not changed, the temperature detected by the ambient sensor will increase. This is because the heat from the engine compartment can radiate to the front grille area, location of the ambient sensor.

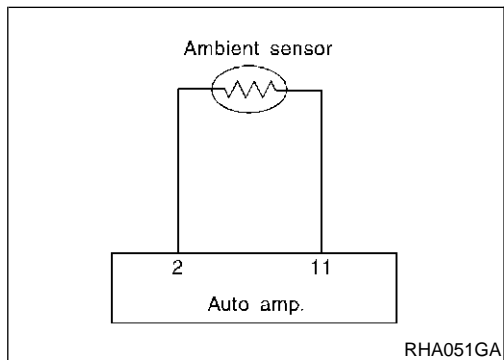

DIAGNOSTIC PROCEDURE

NFHA0216

SYMPTOM: Ambient sensor circuit is open or shorted. (∞ or $-\infty$ is indicated on the display as a result of conducting Self-diagnosis STEP 2.)

1	CHECK VOLTAGE BETWEEN AMBIENT SENSOR HARNESS CONNECTOR AND GROUND	
Disconnect ambient sensor harness connector. Do approx. 5 volts exist between ambient sensor harness connector terminal No. 1 and ground?		
<p>The diagram shows a voltmeter (V) with its positive lead connected to terminal 1 of the 'Ambient sensor connector (E55)'. The negative lead is connected to a ground symbol. A 'DISCONNECT' icon is shown next to the connector. The text 'B/OR' is written near the voltmeter.</p>		
RHA052GF		
Yes or No		
Yes	▶	GO TO 2.
No	▶	GO TO 4.

2	CHECK AMBIENT SENSOR CIRCUIT BETWEEN AMBIENT SENSOR AND AUTO AMP. (LCU)	
<p>1. Disconnect auto amp. (LCU) harness connector. 2. Check circuit continuity between ambient sensor harness connector terminal No. 2 and auto amp. (LCU) harness connector terminal No. 11.</p>		
RHA475GE		
<p>Continuity should exist. If OK, check harness for short.</p>		
OK or NG		
OK	▶	GO TO 3.
NG	▶	Repair harness or connector.

3	CHECK AMBIENT SENSOR	
Refer to HA-126.		
OK or NG		
OK	▶	1. Replace auto amp. (LCU). 2. Go to "FUNCTION CONFIRMATION PROCEDURE", "Self-diagnosis", HA-44; Without Navigation System or HA-54; With Navigation System and perform self-diagnosis STEP-2. Confirm that code No. 20 is displayed.
NG	▶	Replace ambient sensor.

GI
 MA
 EM
 LC
 EC
 FE
 CL
 MT
 AT
 AX
 SU
 BR
 ST
 RS
 BT
 HA
 SC
 EL
 IDX

4	CHECK AMBIENT SENSOR CIRCUIT BETWEEN AMBIENT SENSOR AND AUTO AMP. (LCU)
<p>1. Disconnect auto amp. (LCU) harness connector. 2. Check circuit continuity between ambient sensor harness connector terminal No. 1 and auto amp. (LCU) harness connector terminal No. 2.</p> <div style="text-align: center; margin: 10px 0;"> </div> <p style="text-align: right; margin-top: 10px;">SHA374FA</p> <p style="margin-top: 10px;">Continuity should exist. If OK, check harness for short.</p> <p style="text-align: center; margin-top: 10px;">OK or NG</p>	
OK	<p>▶ 1. Replace auto amp. (LCU). 2. Go to "FUNCTION CONFIRMATION PROCEDURE", "Self-diagnosis", HA-44; Without Navigation System or HA-54; With Navigation System and perform self-diagnosis STEP-2. Confirm that code No. 20 is displayed.</p>
NG	<p>▶ Repair harness or connector.</p>

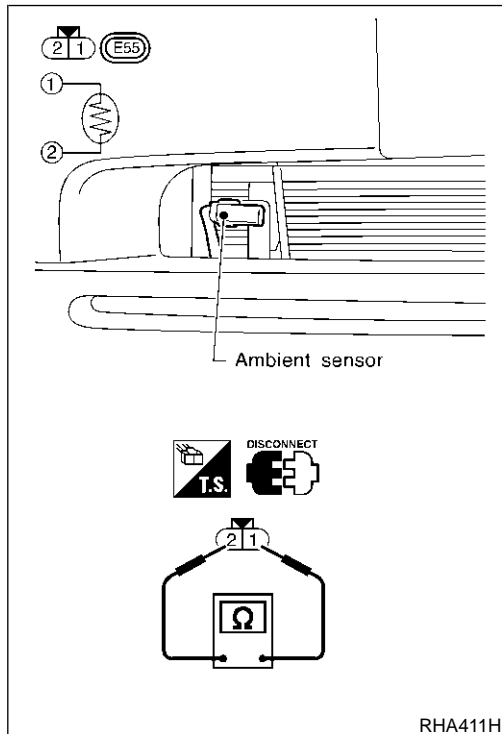

COMPONENT INSPECTION

NFHA0217

Ambient Sensor

NFHA0217S01

After disconnecting ambient sensor harness connector, measure resistance between terminals 2 and 1 at sensor harness side, using the table below.

Temperature °C (°F)	Resistance kΩ
-15 (5)	12.73
-10 (14)	9.92
-5 (23)	7.80
0 (32)	6.19
5 (41)	4.95
10 (50)	3.99
15 (59)	3.24
20 (68)	2.65
25 (77)	2.19
30 (86)	1.81

Temperature °C (°F)	Resistance kΩ
35 (95)	1.51
40 (104)	1.27
45 (113)	1.07

If NG, replace ambient sensor.

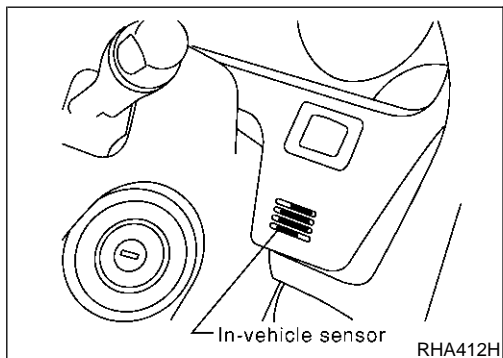

In-vehicle Sensor Circuit COMPONENT DESCRIPTION

In-vehicle sensor

The in-vehicle sensor is located on instrument lower panel. It converts variations in temperature of compartment air drawn from the aspirator into a resistance value. It is then input into the auto amplifier.

NFHA0218

NFHA0218S01

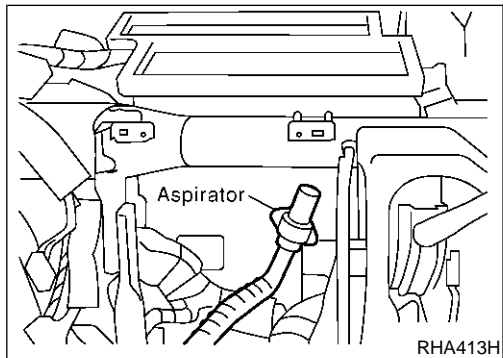

Aspirator

The aspirator is located in front of heater unit. It produces vacuum pressure due to air discharged from the heater unit, continuously taking compartment air in the aspirator.

NFHA0218S02

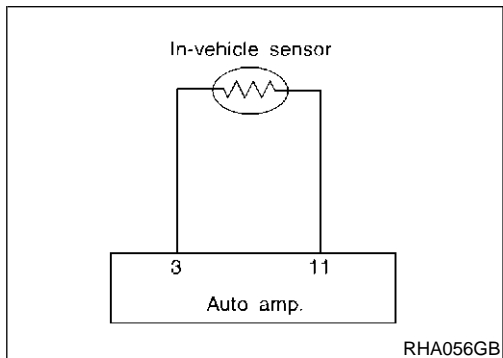
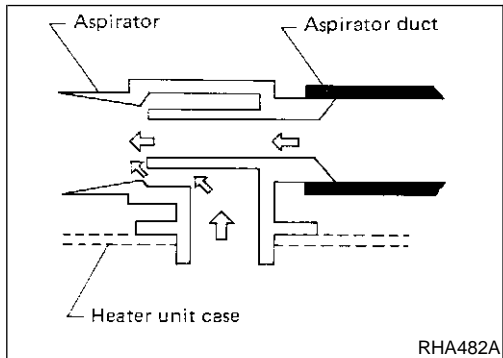

DIAGNOSTIC PROCEDURE

SYMPTOM: In-vehicle sensor circuit is open or shorted. (⌘⌘ or ⌘⌘ is indicated on the display as a result of conducting Self-diagnosis STEP 2.)

NEHA0219

GI
 MA
 EM
 LC
 EC
 FE
 CL
 MT
 AT
 AX
 SU
 BR
 ST
 RS
 BT
 HA
 SC
 EL
 IDX

In-vehicle Sensor Circuit (Cont'd)

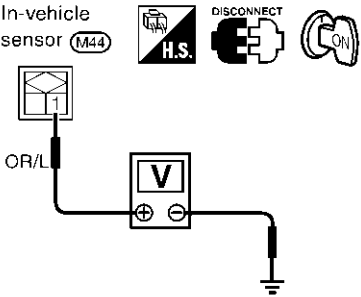
1	CHECK IN-VEHICLE SENSOR CIRCUIT BETWEEN IN-VEHICLE SENSOR AND GROUND	
<p>Disconnect in-vehicle sensor harness connector. Do approx. 5 volts exist between in-vehicle sensor harness connector terminal No. 1 and ground?</p>		
		
SHA318F		
Yes or No		
Yes	▶	GO TO 2.
No	▶	GO TO 4.

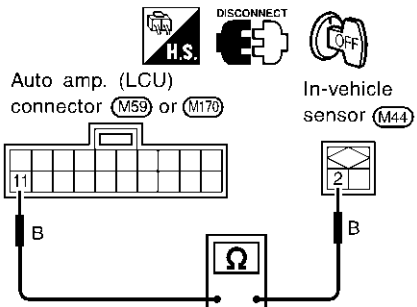
2	CHECK IN-VEHICLE SENSOR CIRCUIT BETWEEN IN-VEHICLE SENSOR AND AUTO AMP. (LCU)	
<p>1. Disconnect auto amp. (LCU) harness connector. 2. Check circuit continuity between in-vehicle sensor harness connector terminal No. 2 and auto amp. (LCU) harness connector terminal No. 11.</p>		
		
RHA478GE		
Continuity should exist.		
If OK, check harness for short.		
OK or NG		
OK	▶	GO TO 3.
NG	▶	Repair harness or connector.

3	CHECK IN-VEHICLE SENSOR	
Refer to HA-130.		
OK or NG		
OK	▶	1. Replace auto amp. 2. Go to "FUNCTION CONFIRMATION PROCEDURE", "Self-diagnosis", HA-44; Without Navigation System or HA-54; With Navigation System and perform self-diagnosis STEP-2. Confirm that code No. 20 is displayed.
NG	▶	1. Replace in-vehicle sensor. 2. Go to "FUNCTION CONFIRMATION PROCEDURE", "Self-diagnosis", HA-44; Without Navigation System or HA-54; With Navigation System and perform self-diagnosis STEP-2. Confirm that code No. 20 is displayed.

GI
MA
EM
LC
EC

4	CHECK IN-VEHICLE SENSOR CIRCUIT BETWEEN IN-VEHICLE SENSOR AND AUTO AMP. (LCU)	
1. Disconnect auto amp. (LCU) harness connector. 2. Check circuit continuity between in-vehicle sensor harness connector terminal No. 1 and auto amp. (LCU) harness connector terminal No. 3.		
RHA479GD		
<p style="color: blue;">Continuity should exist.</p> If OK, check harness for short.		
OK or NG		
OK	▶	1. Replace auto amp. (LCU). 2. Go to "FUNCTION CONFIRMATION PROCEDURE", "Self-diagnosis", HA-44; Without Navigation System or HA-54; With Navigation System and perform self-diagnosis STEP-2. Confirm that code No. 20 is displayed.
NG	▶	Repair harness or connector.

FE
CL
MT
AT
AX
SU
BR
ST
RS
BT

HA

SC
EL
IDX

In-vehicle Sensor Circuit (Cont'd)

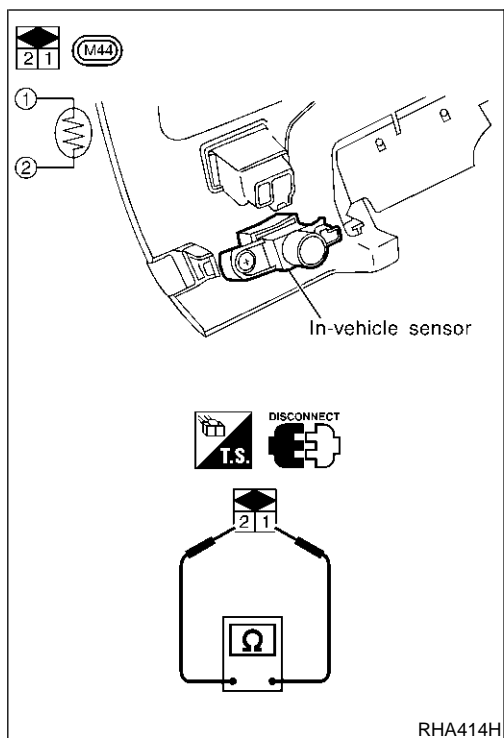

COMPONENT INSPECTION

NFHA0220

In-vehicle Sensor

NFHA0220S01

After disconnecting in-vehicle sensor harness connector, measure resistance between terminals 1 and 2 at sensor harness side, using the table below.

Temperature °C (°F)	Resistance kΩ
-15 (5)	12.73
-10 (14)	9.92
-5 (23)	7.80
0 (32)	6.19
5 (41)	4.95
10 (50)	3.99
15 (59)	3.24
20 (68)	2.65
25 (77)	2.19
30 (86)	1.81
35 (95)	1.51
40 (104)	1.27
45 (113)	1.07

If NG, replace in-vehicle sensor.

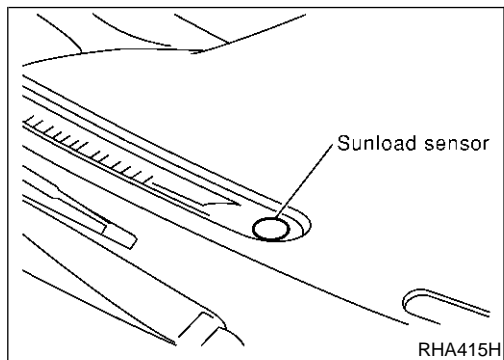

Sunload Sensor Circuit

COMPONENT DESCRIPTION

NFHA0221

The sunload sensor is located on the right defroster grille. It detects sunload entering through windshield by means of a photo diode. The sensor converts the sunload into a current value which is then input into the auto amplifier.

SUNLOAD INPUT PROCESS

NFHA0222

The auto amp. also includes a processing circuit which "average" the variations in detected sunload over a period of time. This prevents drastic swings in the ATC (Automatic Temperature Control) system operation due to small or quick variations in detected sunload.

For example, consider driving along a road bordered by an occasional group of large trees. The sunload detected by the sunload sensor will vary whenever the trees obstruct the sunlight. The processing circuit averages the detected sunload over a period of time, so that the (insignificant) effect of the trees momentarily

TROUBLE DIAGNOSES

AUTO

Sunload Sensor Circuit (Cont'd)

obstructing the sunlight does not cause any change in the ATC system operation. On the other hand, shortly after entering a long tunnel, the system will recognize the change in sunload, and the system will react accordingly.

GI

MA

EM

LC

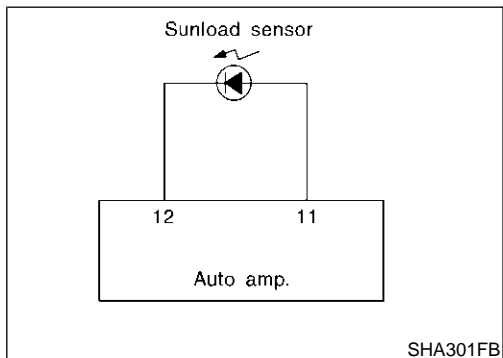

DIAGNOSTIC PROCEDURE

SYMPTOM: Sunload sensor circuit is open or shorted. (25 or -25 is indicated on the display as a result of conducting Self-diagnosis STEP 2.)

NEHA0223

EC

FE

CL

MT

1	CHECK SUNLOAD SENSOR CIRCUIT BETWEEN SUNLOAD SENSOR AND GROUND	
<p>Disconnect sunload sensor harness connector. Do approx. 5 volts exist between sunload sensor harness connector terminal No. 1 and ground?</p>		
RHA062GD		
Yes or No		
Yes	▶	GO TO 2.
No	▶	GO TO 4.

AT

AX

SU

BR

ST

RS

BT

HA

SC

EL

IDX

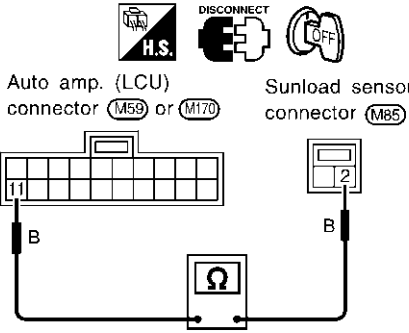
2	CHECK SUNLOAD SENSOR CIRCUIT BETWEEN SUNLOAD SENSOR AND AUTO AMP. (LCU)	
<ol style="list-style-type: none"> 1. Disconnect auto amp. (LCU) harness connector. 2. Check circuit continuity between sunload sensor harness connector terminal No. 2 and auto amp. (LCU) harness connector terminal No. 11. 		
		
RHA483GE		
<p>Continuity should exist. If OK, check harness for short.</p> <p style="text-align: center;">OK or NG</p>		
OK	▶	GO TO 3.
NG	▶	Repair harness or connector.

3	CHECK SUNLOAD SENSOR	
Refer to HA-133.		
OK or NG		
OK	▶	<ol style="list-style-type: none"> 1. Replace auto amp. (LCU). 2. Go to "FUNCTION CONFIRMATION PROCEDURE", "Self-diagnosis", HA-44; Without Navigation System or HA-54; With Navigation System and perform self-diagnosis STEP-2. Confirm that code No. 20 is displayed.
NG	▶	<ol style="list-style-type: none"> 1. Replace sunload sensor. 2. Go to "FUNCTION CONFIRMATION PROCEDURE", "Self-diagnosis", HA-44; Without Navigation System or HA-54; With Navigation System and perform self-diagnosis STEP-2. Confirm that code No. 20 is displayed.

4	CHECK SUNLOAD SENSOR CIRCUIT BETWEEN SUNLOAD SENSOR AND AUTO AMP. (LCU)	<p>1. Disconnect auto amp. (LCU) harness connector.</p> <p>2. Check circuit continuity between sunload sensor harness connector terminal No. 1 and auto amp. (LCU) harness connector terminal No. 12.</p> <div style="text-align: center; margin: 10px 0;"> </div> <p style="text-align: right; margin-right: 20px;">RHA484GD</p> <p>Continuity should exist. If OK, check harness for short.</p> <p style="text-align: center; margin: 10px 0;">OK or NG</p>	GI MA EM LC EC FE CL MT AT AX SU BR
OK	▶	<p>1. Replace auto amp.</p> <p>2. Go to "FUNCTION CONFIRMATION PROCEDURE", "Self-diagnosis", HA-44; Without Navigation System or HA-54; With Navigation System and perform self-diagnosis STEP-2. Confirm that code No. 20 is displayed.</p>	
NG	▶	Repair harness or connector.	

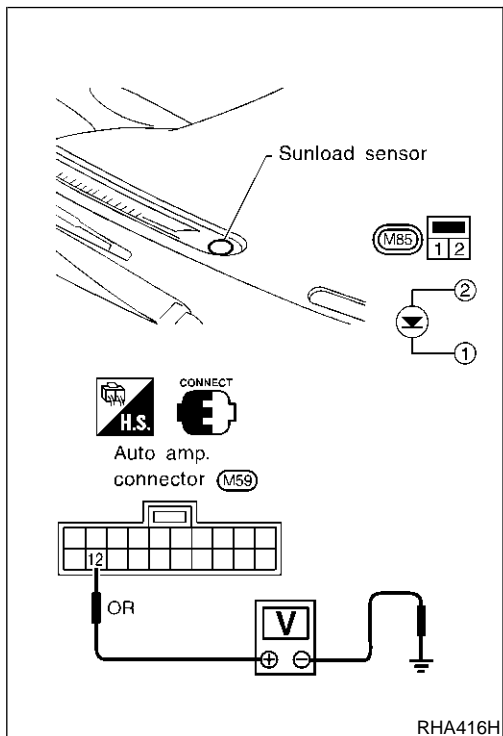

COMPONENT INSPECTION

Sunload Sensor

NFHA0224

NFHA0224S01

Measure voltage between auto amp. terminal 12 and ground.
If NG, replace sunload sensor.

- **When checking sunload sensor, select a place where sun shines directly on it.**

Sunload Sensor Circuit (Cont'd)

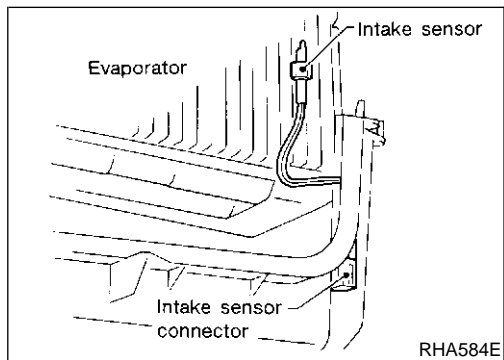
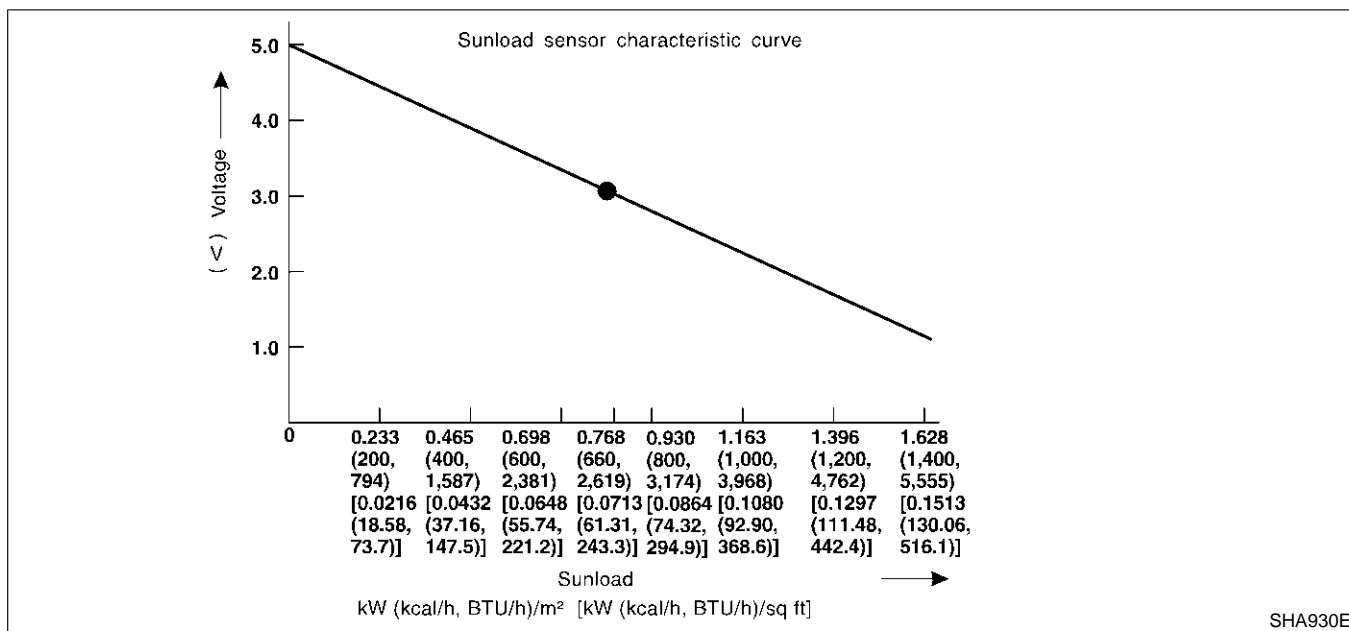

Intake Sensor Circuit COMPONENT DESCRIPTION Intake Sensor

NFHA0225

NFHA0225S01

The intake sensor is located on the cooling unit. It converts temperature of air after it passes through the evaporator into a resistance value which is then input to the auto amp.

After disconnecting intake sensor harness connector, measure resistance between terminals 1 and 2 at sensor harness side, using the table below.

Temperature °C (°F)	Resistance kΩ
-15 (5)	12.73
-10 (14)	9.92
-5 (23)	7.80
0 (32)	6.19
5 (41)	4.95
10 (50)	3.99
15 (59)	3.24
20 (68)	2.65
25 (77)	2.19
30 (86)	1.81
35 (95)	1.51
40 (104)	1.27
45 (113)	1.07

If NG, replace intake sensor.

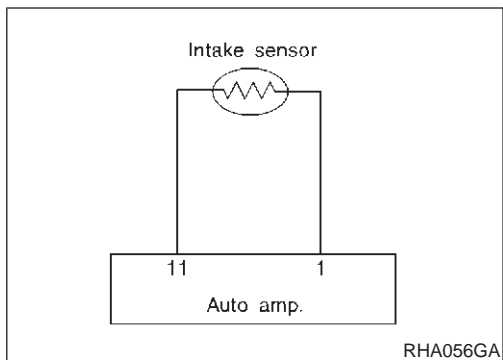

DIAGNOSTIC PROCEDURE

SYMPTOM: Intake sensor circuit is open or shorted. (24 or -24 is indicated on the display as a result of conducting Self-diagnosis STEP 2.)

NFHA0226

GI

MA

EM

LC

EC

FE

CL

MT

AT

AX

SU

BR

ST

RS

BT

HA

SC

EL

IDX

1 CHECK INTAKE SENSOR CIRCUIT BETWEEN INTAKE SENSOR AND GROUND

Disconnect intake sensor harness connector.

Do approx. 5 volts exist between intake sensor harness connector terminal No. 1 and ground?

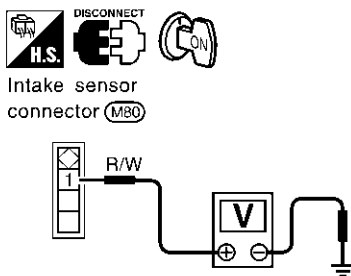

RHA417H

Yes or No

Yes ► GO TO 2.

No ► GO TO 4.

2 CHECK INTAKE SENSOR CIRCUIT BETWEEN INTAKE SENSOR AND AUTO AMP. (LCU)

1. Disconnect auto amp. (LCU) harness connector.

2. Check circuit continuity between intake sensor harness connector terminal No. 2 and auto amp. (LCU) harness connector terminal No. 11.

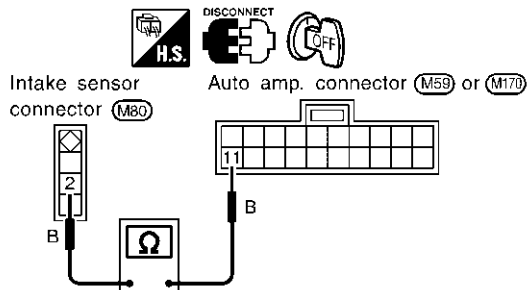

RHA418HA

Continuity should exist.

If OK, check harness for short.

OK or NG

OK ► GO TO 3.

NG ► Repair harness or connector.

Intake Sensor Circuit (Cont'd)

3	CHECK INTAKE SENSOR	
Refer to HA-134.		
OK or NG		
OK	▶	1. Replace auto amp. 2. Go to "FUNCTION CONFIRMATION PROCEDURE", "Self-diagnosis", HA-44; Without Navigation System or HA-54; With Navigation System and perform self-diagnosis STEP-2. Confirm that code No. 20 is displayed.
NG	▶	1. Replace intake sensor. 2. Go to "FUNCTION CONFIRMATION PROCEDURE", "Self-diagnosis", HA-44; Without Navigation System or HA-54; With Navigation System and perform self-diagnosis STEP-2. Confirm that code No. 20 is displayed.

4	CHECK INTAKE SENSOR CIRCUIT BETWEEN INTAKE SENSOR AND AUTO AMP. (LCU)	
1. Disconnect auto amp. (LCU) harness connector. 2. Check circuit continuity between intake sensor harness connector terminal No. 1 and auto amp. (LCU) harness connector terminal No. 1.		
RHA419HA		
<p style="color: blue;">Continuity should exist.</p> <p>If OK, check harness for short.</p>		
OK or NG		
OK	▶	1. Replace auto amp. 2. Go to "FUNCTION CONFIRMATION PROCEDURE", "Self-diagnosis", HA-44; Without Navigation System or HA-54; With Navigation System and perform self-diagnosis STEP-2. Confirm that code No. 20 is displayed.
NG	▶	Repair harness or connector.

Air Mix Door Motor PBR Circuit DIAGNOSTIC PROCEDURE

NFHA0227

For description of air mix door motor circuit, refer to HA-85.

SYMPTOM: If PBR circuit is open or shorted. (–25 or 25 is indicated on the display as a result of conducting Self-diagnosis STEP 2.)

Perform diagnostic procedure for air mix door motor, mode door motor and intake. Refer to HA-78.

NFHA0285

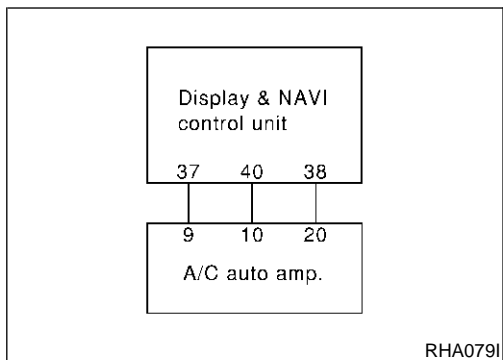

Multiplex Communication Circuit

DIAGNOSTIC PROCEDURE

SYMPTOM:

- A/C system does not come on.
- A/C system can not controlled.

GI
MA
EM
LC
EC
FE
CL
MT
AT
AX
SU
BR
ST
RS
BT
HA
SC
EL
IDX

1 CHECK CIRCUIT CONTINUITY BETWEEN DISPLAY & NAVI CONTROL UNIT AND AUTO AMP.

Check circuit continuity between each terminal on Display & Navigation control unit and on auto amp.

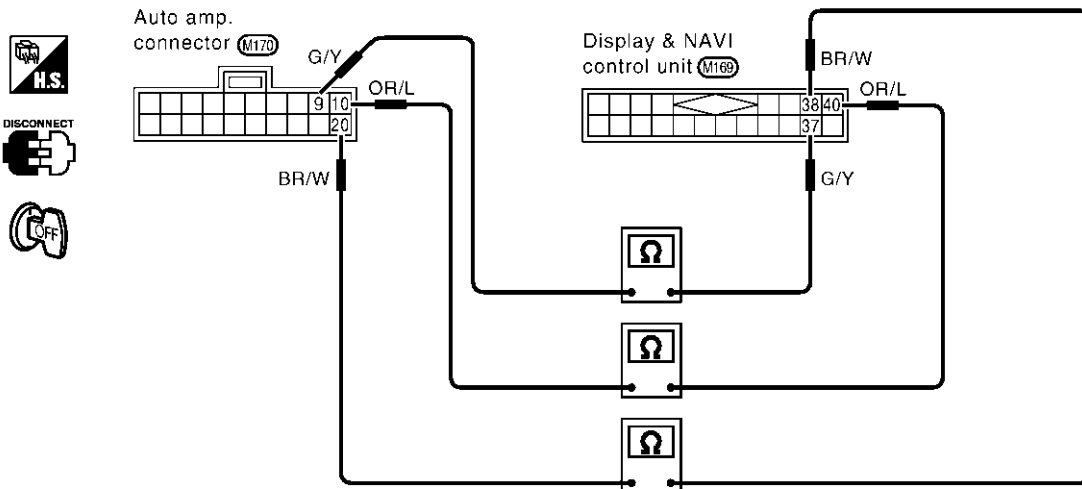

SHA622F

Continuity should exist.

If OK, check harness for short.

OK or NG

OK	▶	GO TO 2.
NG	▶	1. Repair harness or connector. 2. Go to "OPERATIONAL CHECK", HA-67. Confirm that A/C system is in good order.

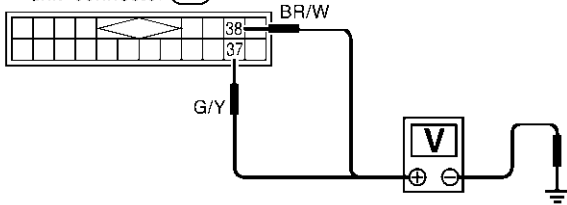
2	CHECK MULTI-PLEX COMMUNICATION SIGNAL	
<p>Do approx. 3.5 volts exist between Display & NAVI control unit harness connector terminal Nos. 37, 38 and ground?</p> <div style="text-align: center;">  <p>Display & NAVI control unit connector (M169)</p>  </div> <p style="text-align: right;">RHA890HB</p> <p style="text-align: center;">Yes or No</p>		
Yes	▶	GO TO 3.
No	▶	<ol style="list-style-type: none"> 1. Replace auto amp. 2. Go to "OPERATIONAL CHECK", HA-67. <p style="margin-left: 20px;">Confirm that A/C system is in good order.</p>

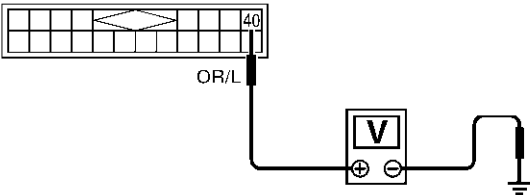
3	CHECK MULTIPLEX COMMUNICATION SIGNAL	
<p>Do approx. 3.5 volts exist between auto amp. harness connector terminal No. 40 and ground?</p> <div style="text-align: center;">  <p>Display & NAVI control unit connector (M169)</p>  </div> <p style="text-align: right;">RHA891HB</p> <p style="text-align: center;">Yes or No</p>		
Yes	▶	INSPECTION END.
No	▶	<ol style="list-style-type: none"> 1. Replace Display & NAVI control unit. 2. Go to "OPERATIONAL CHECK", HA-67. <p style="margin-left: 20px;">Confirm that A/C system is in good order.</p>

HFC-134a (R-134a) Service Procedure

NFHA0228

NFHA0228S01

NFHA0228S0101

SETTING OF SERVICE TOOLS AND EQUIPMENT

Discharging Refrigerant

WARNING:

Avoid breathing A/C refrigerant and lubricant vapor or mist. Exposure may irritate eyes, nose and throat. Remove HFC-134a (R-134a) from A/C system using certified service equipment meeting requirements of SAE J2210 [HFC-134a (R-134a) recycling equipment] or J2209 [HFC-134a (R-134a) recovery equipment]. If accidental system discharge occurs, ventilate work area before resuming service. Additional health and safety information may be obtained from refrigerant and lubricant manufacturers.

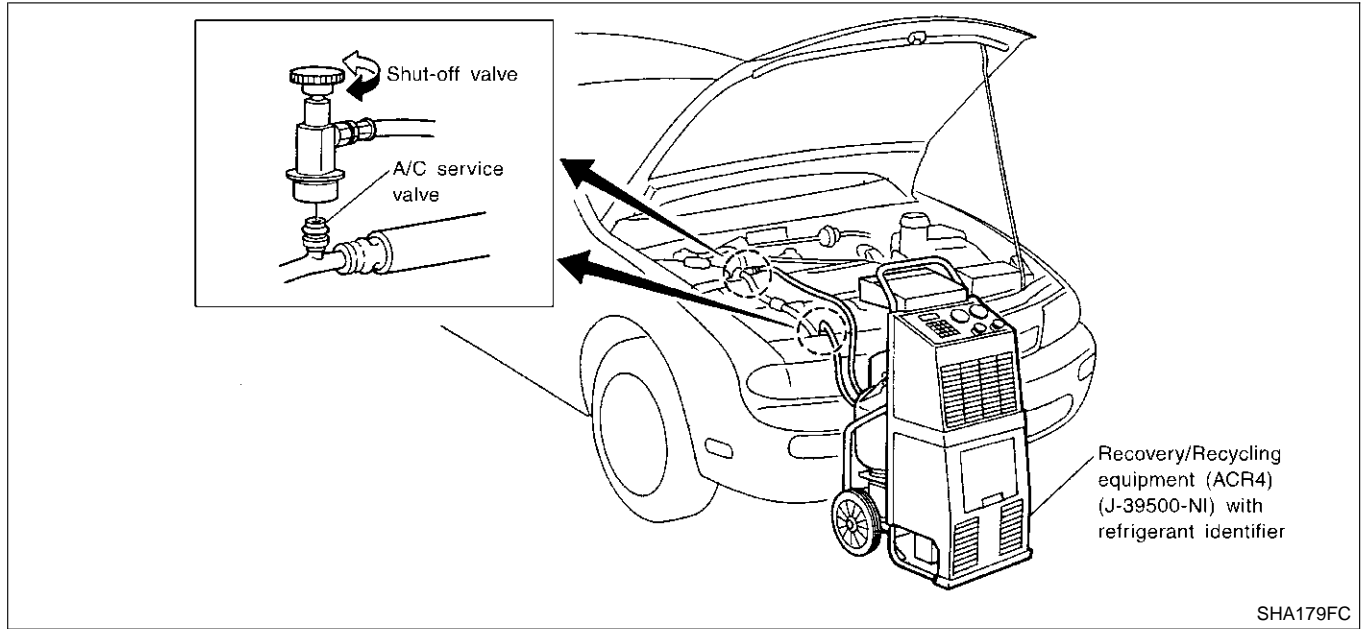

Evacuating System and Charging Refrigerant

NFHA0228S0102

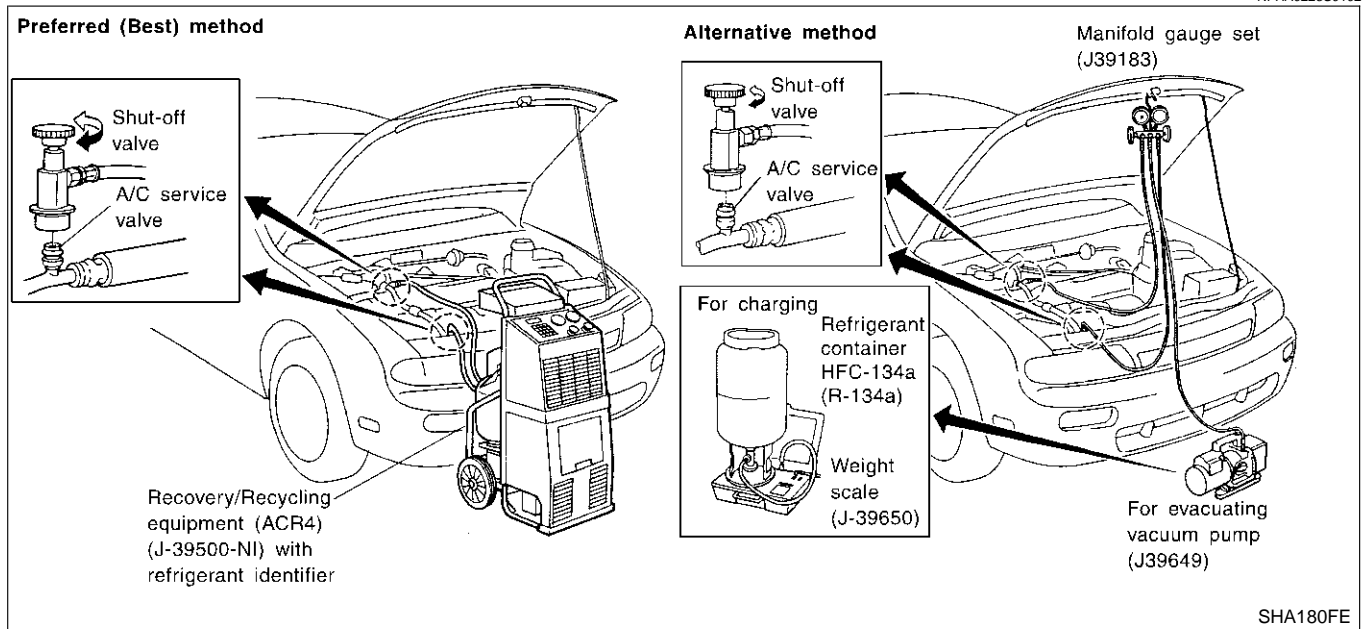

GI
MA
EM
LC
EC
FE
CL
MT
AT
AX
SU
BR
ST
RS
BT
HA
SC
EL
IDX

SERVICE PROCEDURE

AUTO

HFC-134a (R-134a) Service Procedure (Cont'd)

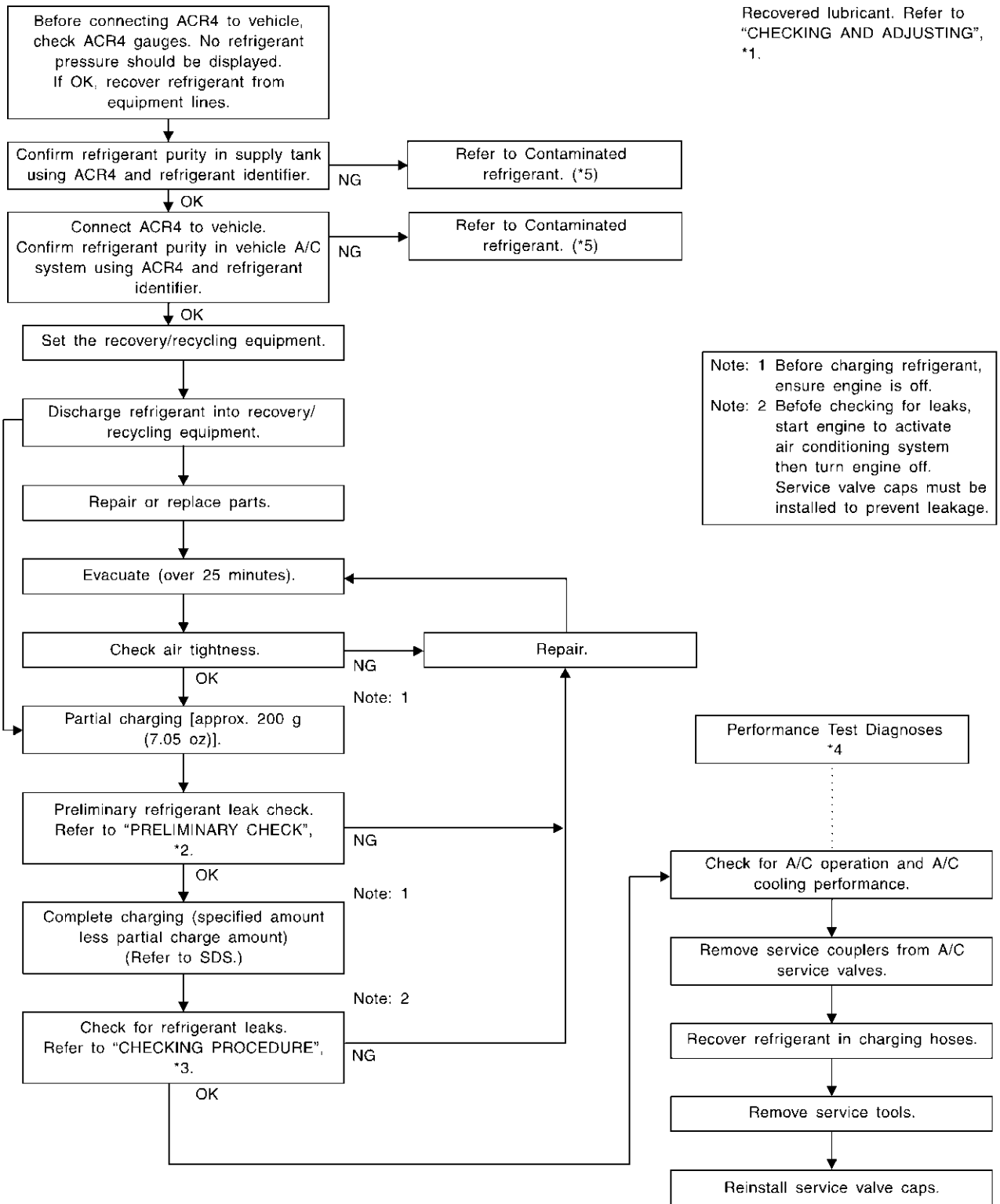

Recovered lubricant. Refer to "CHECKING AND ADJUSTING", *1.

Note: 1 Before charging refrigerant, ensure engine is off.
 Note: 2 Before checking for leaks, start engine to activate air conditioning system then turn engine off. Service valve caps must be installed to prevent leakage.

*1: HA-141
 *2: HA-151

*3: HA-152
 *4: HA-110

*5: HA-3

SHA251F

Maintenance of Lubricant Quantity in Compressor

NFHA0229

The lubricant in the compressor circulates through the system with the refrigerant. Add lubricant to compressor when replacing any component or after a large gas leakage occurred. It is important to maintain the specified amount. If lubricant quantity is not maintained properly, the following malfunctions may result:

- Lack of lubricant: May lead to a seized compressor
- Excessive lubricant: Inadequate cooling (thermal exchange interference)

LUBRICANT

NFHA0229S01

Name: Nissan A/C System Oil Type S
Part number: KLH00-PAGS0

CHECKING AND ADJUSTING

NFHA0229S02

Adjust the lubricant quantity according to the test group shown below.

1	CHECK LUBRICANT RETURN OPERATION	
Can lubricant return operation be performed?		
<ul style="list-style-type: none"> ● A/C system works properly. ● There is no evidence of a large amount of lubricant leakage. 		
Yes or No		
Yes	▶	GO TO 2.
No	▶	GO TO 3.

2	PERFORM LUBRICANT RETURN OPERATION, PROCEEDING AS FOLLOWS:	
1. Start engine, and set the following conditions:		
Test condition		
Engine speed: Idling to 1,200 rpm		
AUTO switch: ON		
Blower speed: Max. position		
Temp. control: Optional [Set so that intake air temperature is 25 to 30°C (77 to 86°F).]		
2. Next item is for V-6 compressor. Connect the manifold gauge, and check that the high pressure side pressure is 588 kPa (6 kg/cm ² , 85 psi) or higher.		
If less than the reference level, attach a cover to the front face of the condenser to raise the pressure.		
3. Perform lubricant return operation for about 10 minutes.		
4. Stop engine.		
CAUTION:		
If excessive lubricant leakage is noted, do not perform the lubricant return operation.		
OK	▶	GO TO 3.

3	CHECK COMPRESSOR	
Should the compressor be replaced?		
Yes or No		
Yes	▶	Go to "Lubricant Adjustment Procedure for Compressor Replacement", (HA-142).
No	▶	GO TO 4.

GI
MA
EM
LC
EC
FE
CL
MT
AT
AX
SU
BR
ST
RS
BT
HA
SC
EL
IDX

4	CHECK ANY PART	
Is there any part to be replaced? (Evaporator, condenser, liquid tank or in case there is evidence of a large amount of lubricant leakage.)		
Yes or No		
Yes	▶	Go to "Lubricant Adjusting Procedure for Components Replacement Except Compressor", (HA-142).
No	▶	Carry out the A/C performance test.

Lubricant Adjusting Procedure for Components Replacement Except Compressor

NFHA0229S0201

After replacing any of the following major components, add the correct amount of lubricant to the system.

Amount of lubricant to be added

Part replaced	Lubricant to be added to system	Remarks
	Amount of lubricant mℓ (US fl oz, Imp fl oz)	
Evaporator	75 (2.5, 2.6)	—
Condenser	75 (2.5, 2.6)	—
Liquid tank	5 (0.2, 0.2)	Add if compressor is not replaced. *1
In case of refrigerant leak	30 (1.0, 1.1)	Large leak
	—	Small leak *2

*1: If compressor is replaced, addition of lubricant is included in the table.

*2: If refrigerant leak is small, no addition of lubricant is needed.

Lubricant Adjusting Procedure for Compressor Replacement

NFHA0229S0202

1. Before connecting ACR4 to vehicle, check ACR4 gauges. No refrigerant pressure should be displayed. If NG, recover refrigerant from equipment lines.
2. Connect ACR4 to vehicle. Confirm refrigerant purity in supply tank using ACR4 and refrigerant identifier. If NG, refer to "CONTAMINATED REFRIGERANT", HA-3.
3. Confirm refrigerant purity in vehicle A/C system using ACR4 and refrigerant identifier. If NG, refer to "CONTAMINATED REFRIGERANT", HA-3.
4. Discharge refrigerant into the refrigerant recovery/recycling equipment. Measure lubricant discharged into the recovery/recycling equipment.
5. Remove the drain plug of the "old" (removed) compressor. Drain the lubricant into a graduated container and record the amount of drained lubricant.
6. Remove the drain plug and drain the lubricant from the "new" compressor into a separate, clean container.
7. Measure an amount of new lubricant installed equal to amount drained from "old" compressor. Add this lubricant to "new" compressor through the suction port opening.
8. Measure an amount of new lubricant equal to the amount recovered during discharging. Add this lubricant to "new" compressor through the suction port opening.
9. Torque the drain plug.

18 - 19 N·m (1.8 - 1.9 kg·m, 13 - 14 ft·lb)

10. If the liquid tank also needs to be replaced, add an additional 5 mℓ (0.2 US fl oz, 0.2 Imp fl oz) of lubricant at this time. Do not add this 5 mℓ (0.2 US fl oz, 0.2 Imp fl oz) of lubricant if only replacing the compressor.

GI
MA
EM
LC
EC
FE
CL
MT
AT
AX
SU
BR
ST
RS
BT
HA
SC
EL
IDX

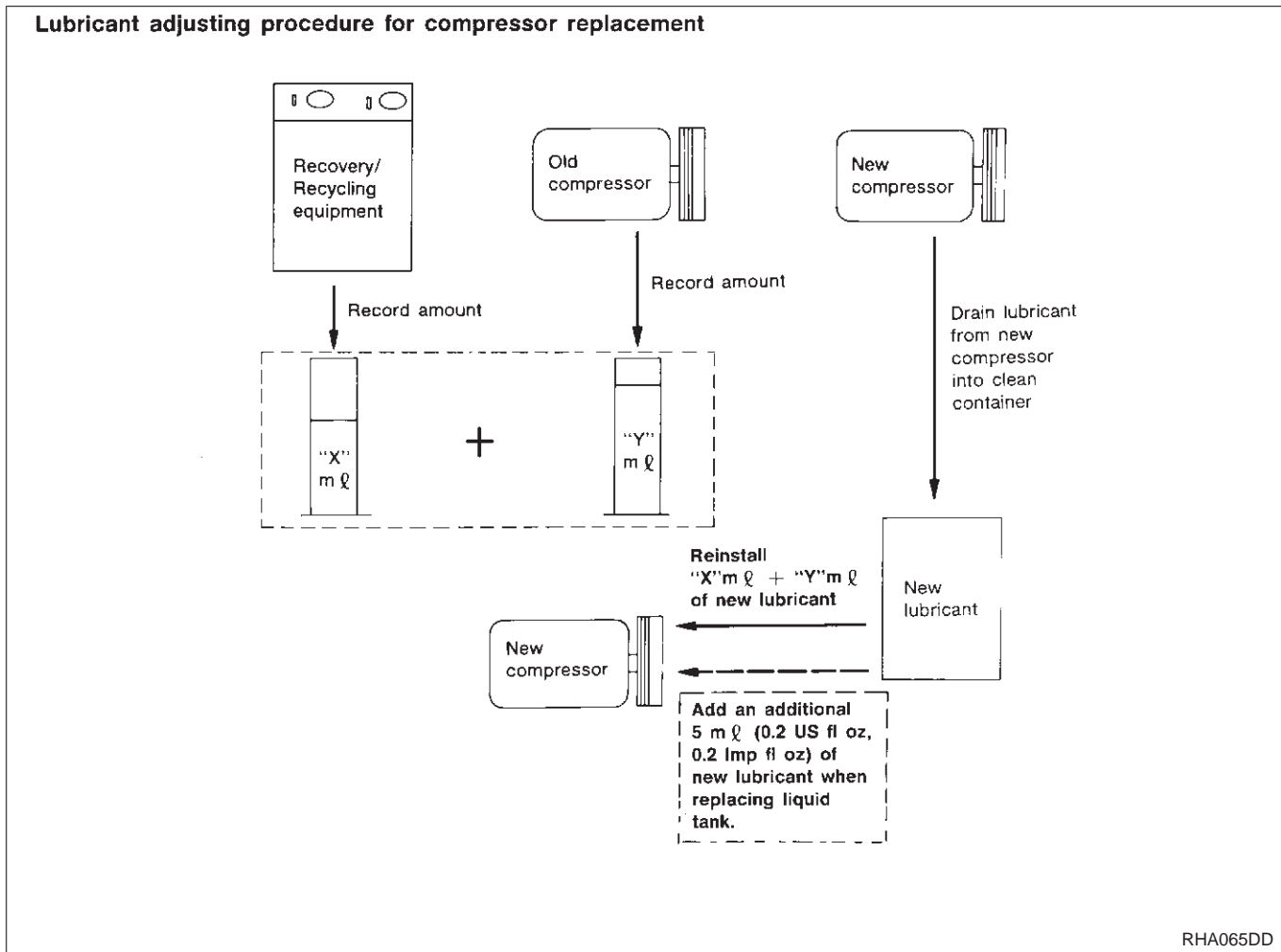

Compressor REMOVAL AND INSTALLATION

NFHA0230

SEC. 274•275

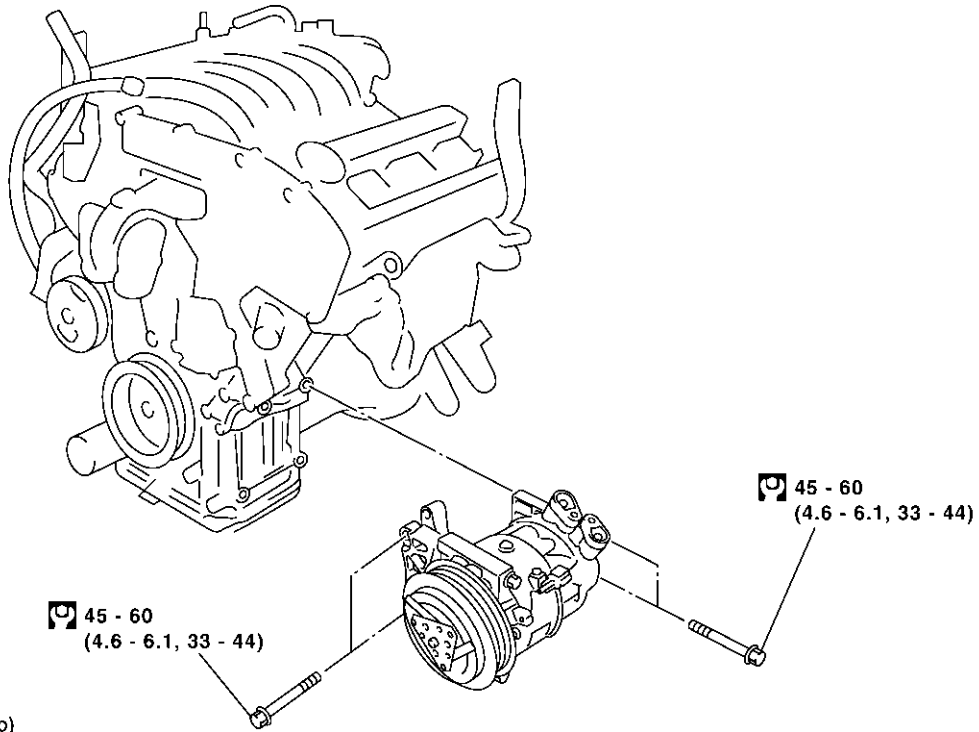

: N·m (kg-m, ft-lb)

CAUTION:
Do not remove the compressor bracket from the compressor.

RHA0621

Compressor Clutch OVERHAUL

NFHA0231

SEC. 274

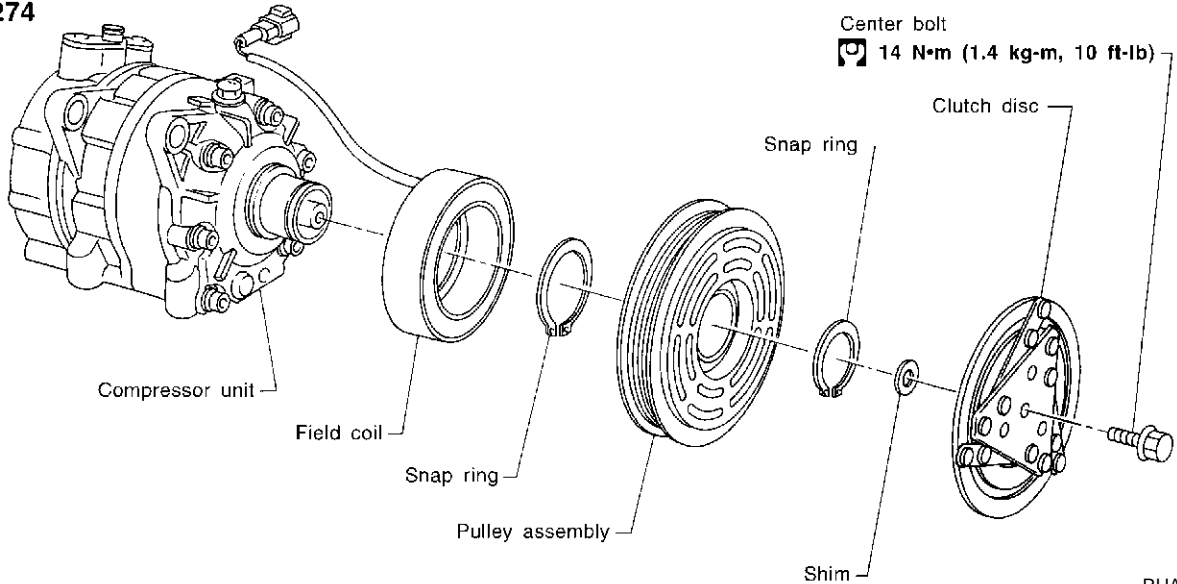

RHA122F

NFHA0232

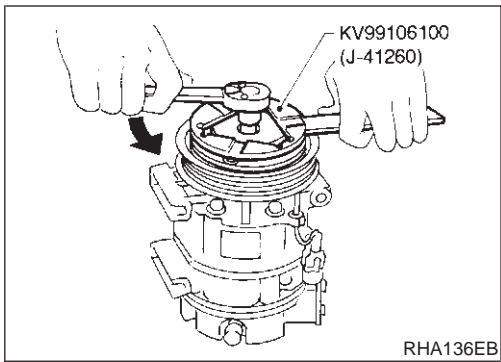

REMOVAL

- When removing center bolt, hold clutch disc with clutch disc wrench.

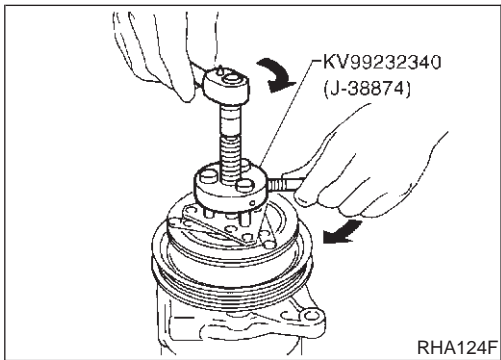
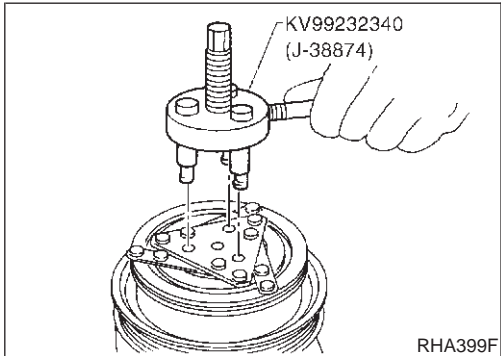

- Remove the clutch disc using the clutch disc puller. Insert the holder's three pins into the holes in the clutch disc. Rotate the holder clockwise to hook it onto the plate. Then, tighten the center bolt to remove the clutch disc. After removing the clutch disc, remove the shims from either the drive shaft or the clutch disc.

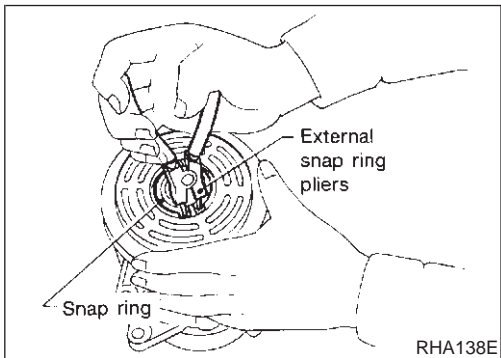

- Remove the snap ring using external snap ring pliers.

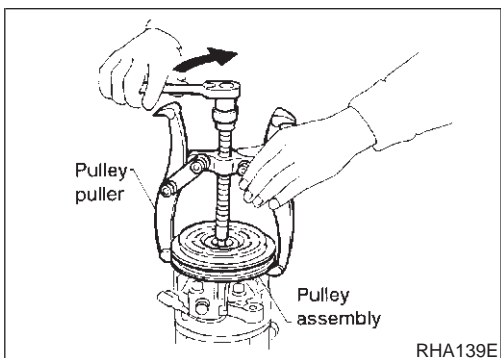

- Pulley removal**
Position the center pulley puller on the end of the drive shaft, and remove the pulley assembly using any commercially available pulley puller.
To prevent the pulley groove from being deformed, the puller claws should be positioned onto the edge of the pulley assembly.

GI

MA

EM

LC

EC

FE

CL

MT

AT

AX

SU

BR

ST

RS

BT

HA

SC

EL

IDX

Compressor Clutch (Cont'd)

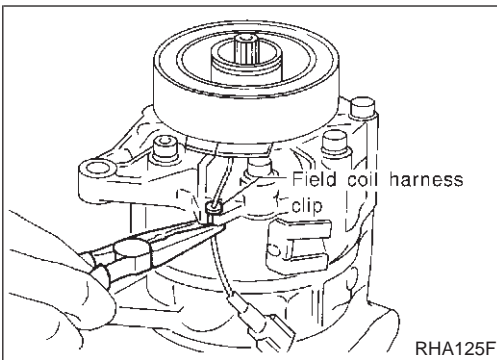

- Remove the field coil harness clip using a pair of pliers.

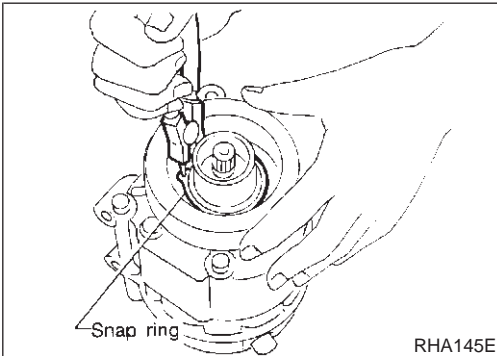

- Remove the snap ring using external snap ring pliers.

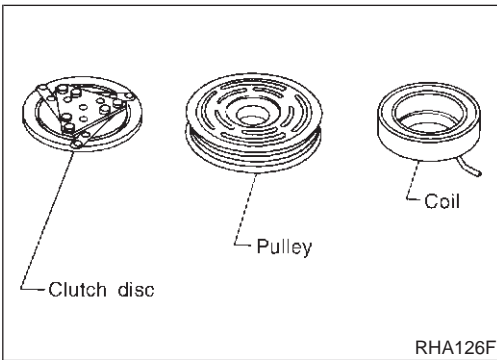

INSPECTION

Clutch Disc

NFHA0233

If the contact surface shows signs of damage due to excessive heat, replace clutch disc and pulley.

NFHA0233S01

Pulley

NFHA0233S02

Check the appearance of the pulley assembly. If the contact surface of pulley shows signs of excessive grooving, replace clutch disc and pulley. The contact surfaces of the pulley assembly should be cleaned with a suitable solvent before reinstallation.

Coil

NFHA0233S03

Check coil for loose connection or cracked insulation.

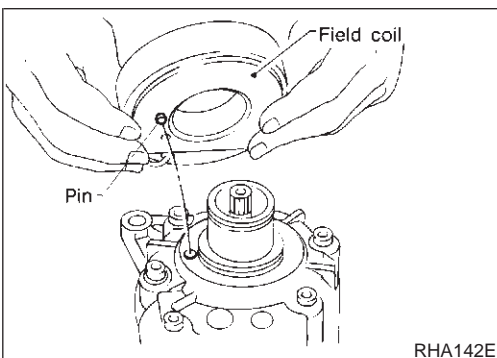

INSTALLATION

NFHA0234

- Install the field coil.
Be sure to align the coil's pin with the hole in the compressor's front head.
- Install the field coil harness clip using a screwdriver.

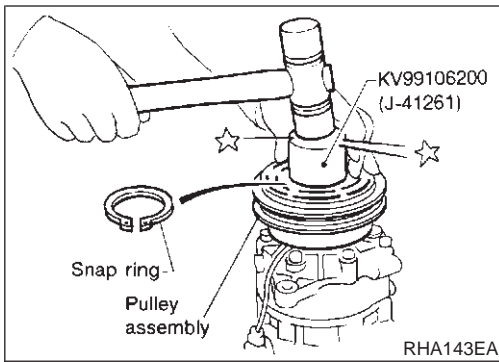

- Install the pulley assembly using the installer and a hand press, and then install the snap ring using snap ring pliers.

GI

MA

EM

LC

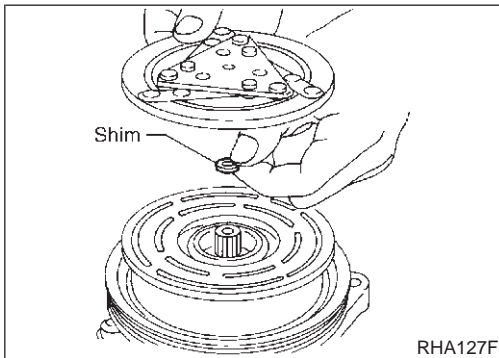

- Install the clutch disc on the drive shaft, together with the original shim(s). Press the clutch disc down by hand.

EC

FE

CL

MT

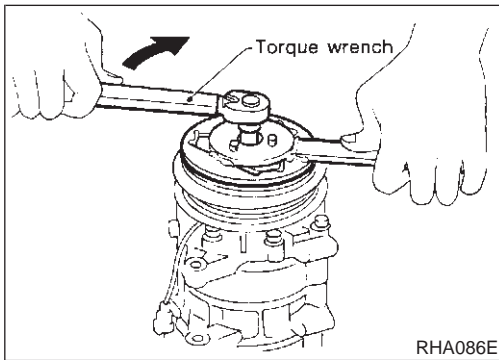

- Using the holder to prevent clutch disc rotation, tighten the bolt to 14 N·m (1.4 kg·m, 10 ft·lb) torque. **After tightening the bolt, check that the pulley rotates smoothly.**

AT

AX

SU

BR

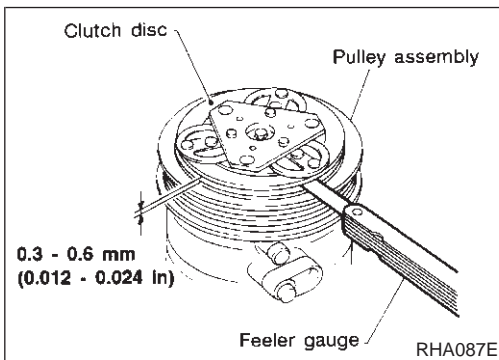

- Check clearance around the entire periphery of clutch disc.

Disc-to-pulley clearance:

0.3 - 0.6 mm (0.012 - 0.024 in)

If the specified clearance is not obtained, replace adjusting spacer and readjust.

ST

RS

BT

HA

Break-in Operation

NFHA0234S01

When replacing compressor clutch assembly, always carry out the break-in operation. This is done by engaging and disengaging the clutch about thirty times. Break-in operation raises the level of transmitted torque.

SC

EL

IDX

Heater Unit (Heater Core) REMOVAL

NFHA0249

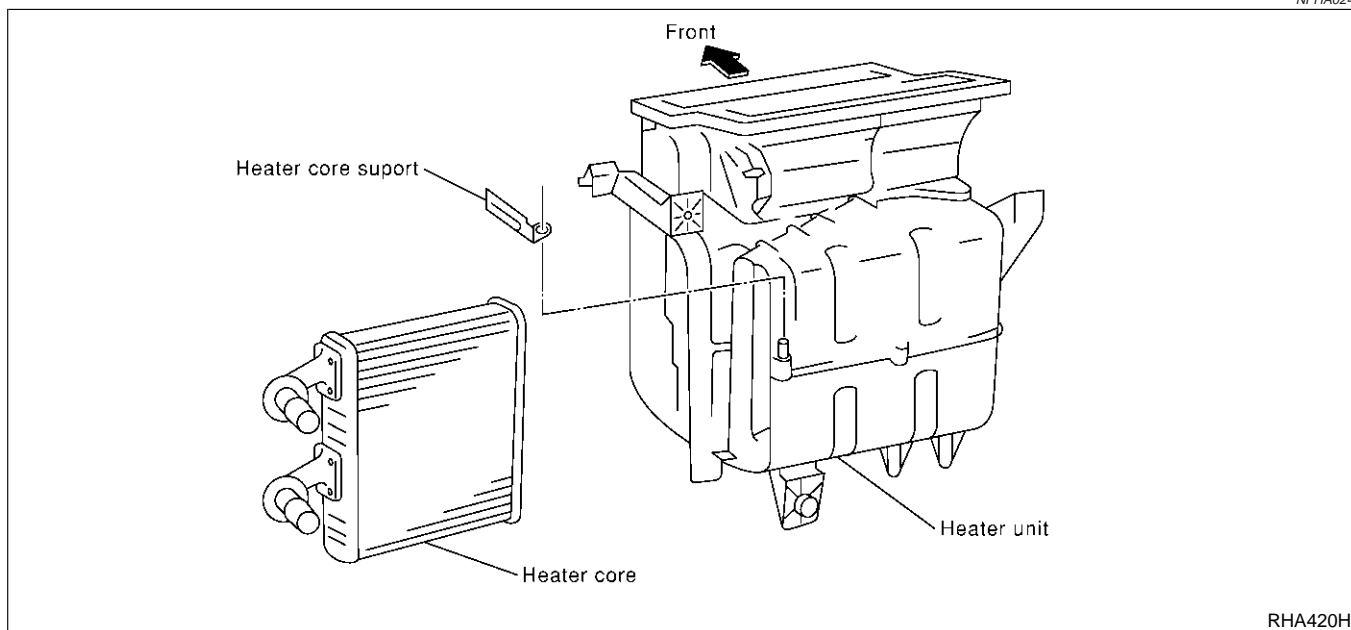

RHA420H

1. Drain the cooling system. Refer to MA-14, "Changing Engine Coolant".
2. Disconnect the two heater hoses from inside the engine compartment.
3. Remove the Blower and cooling unit. Refer to HA-149.
4. Remove the steering member assembly. Refer to BT-29, "Removal and Installation".
5. Remove the heater unit.
6. Remove the heater core.

INSTALLATION

NFHA0250

Installation is basically the reverse order of removal.

When filling radiator with coolant, refer to MA-14, "Changing Engine Coolant".

**Blower and Cooling Unit (A/C Evaporator)
REMOVAL**

NFHA0251

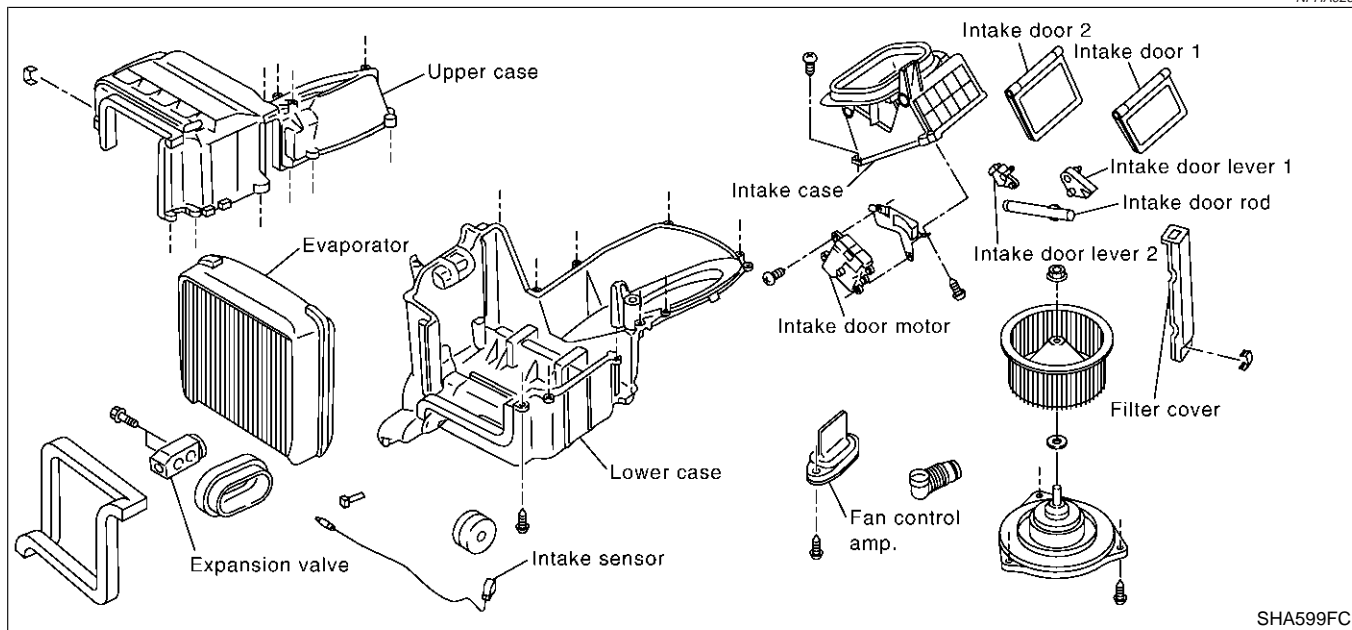

SHA599FC

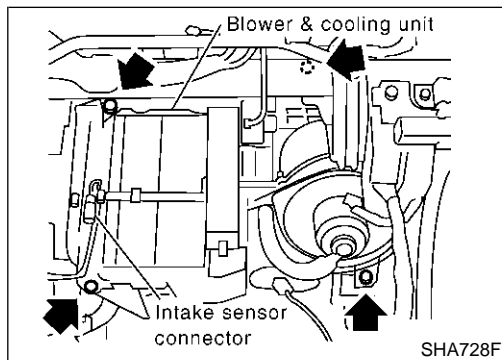

SHA728F

1. Discharge and recover refrigerant from the A/C system. Refer to HA-139.
2. Disconnect the low-pressure and high-pressure lines from the engine compartment. Cap the A/C lines to prevent moisture from entering the A/C system.
3. Remove the glove box and mating trim. Refer to BT-29, "Removal and Installation".
4. Disconnect the intake sensor connector.
5. Disconnect the fan control amp. and blower motor connector.
6. Remove the blower and cooling unit.
7. Separate the blower and cooling unit case, and remove the evaporator.
8. Remove the three bolts and then remove the motor from the blower case.

INSTALLATION

Installation is basically the reverse order of removal.
Recharge the A/C system. Refer to HA-139.

NFHA0252

GI

MA

EM

LC

EC

FE

CL

MT

AT

AX

SU

BR

ST

RS

BT

HA

SC

EL

IDX

CHECKING REFRIGERANT LEAKS

=NFHA0236

Preliminary Check

NFHA0236S01

- Perform a visual inspection of all refrigeration parts, fittings, hoses, and components for signs of A/C lubricant leakage, damage and corrosion. Take note of the areas with A/C lubricant leakage to allow extra time in these areas with electronic leak detector. GI
- If dye is observed, confirm the leak with an electronic refrigerant leak detector. It is possible a prior leak was repaired and not properly cleaned. MA
- When searching for leaks, do not stop when one leak is found but continue to check for additional leaks at all system components and connections. EM
- When searching for leaks, do not stop when one leak is found but continue to check for additional leaks at all system components and connections. LC
- When searching for refrigerant leaks using an electronic leak detector, move the probe along the suspected leak area at 1 to 2 inches per second and no further than 1/4 inch from the component. EC

NOTE:

Moving the electronic leak detector probe slower and closer to the suspected leak area will improve the chances of finding a leak. FE

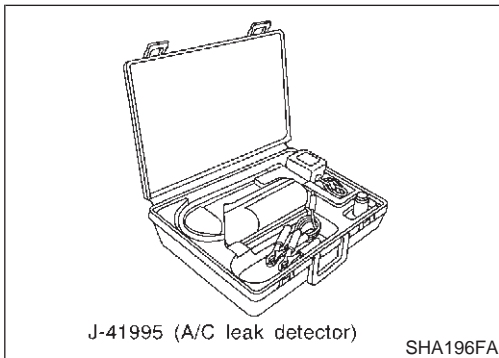

J-41995 (A/C leak detector)

SHA196FA

ELECTRONIC REFRIGERANT LEAK DETECTOR

NFHA0269

Precautions for Handling Leak Detector

NFHA0269S01

When performing a refrigerant leak check, use a J-41995 A/C leak detector or equivalent. Ensure that the instrument is calibrated and set properly per the operating instructions. AT

The leak detector is a delicate device. In order to use the leak detector properly, read the operating instructions and perform any specified maintenance. AX

Other gases in the work area or substances on the A/C components, for example, anti-freeze, windshield washer fluid, solvents and lubricants, may falsely trigger the leak detector. Make sure the surfaces to be checked are clean. Clean with a dry cloth or blow off with shop air. Do not allow the sensor tip of the detector to contact with any substance. This can also cause false readings and may damage the detector. SU

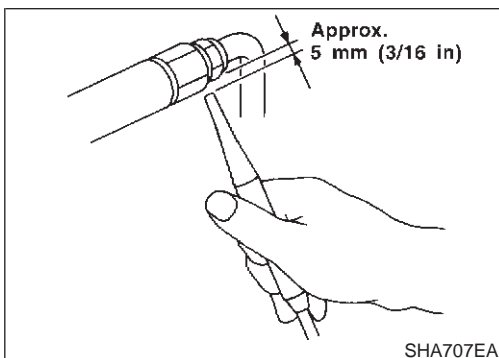

SHA707EA

1. Position probe approximately 5 mm (3/16 in) away from point to be checked. BR

HA

SC

EL

IDX

Refrigerant Lines (Cont'd)

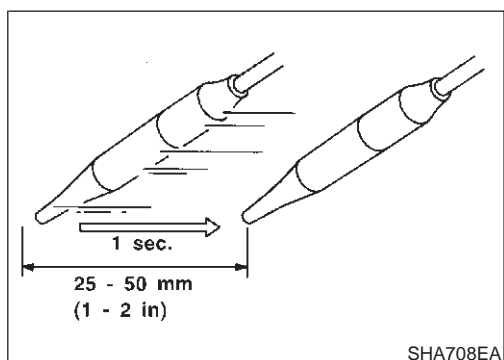
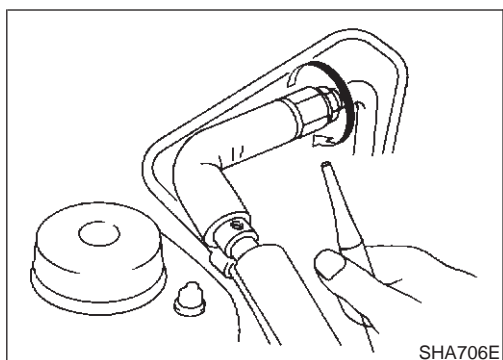

2. When testing, circle each fitting completely with probe.
3. Move probe along component approximately 25 to 50 mm (1 to 2 in)/sec.

Checking Procedure

NFHA0269S02

To prevent inaccurate or false readings, make sure there is no refrigerant vapor, shop chemicals, or cigarette smoke in the vicinity of the vehicle. Perform the leak test in calm area (low air/wind movement) so that the leaking refrigerant is not dispersed.

1. Turn engine off.
2. Connect a suitable A/C manifold gauge set to the A/C service ports.
3. Check if the A/C refrigerant pressure is at least 345 kPa (3.52 kg/cm², 50 psi) above 16°C (61°F). If less than specification, recover/evacuate and recharge the system with the specified amount of refrigerant.

NOTE:

At temperatures below 16°C (61°F), leaks may not be detected since the system may not reach 345 kPa (3.52 kg/cm², 50 psi).

4. Conduct the leak test from the high side (compressor discharge **a** to evaporator inlet **f**) to the low side (evaporator discharge **f** to shaft seal **k**). Refer to HA-150. Perform a leak check for the following areas carefully. Clean the component to be checked and move the leak detector probe completely around the connection/component.

- **Compressor**
Check the fitting of high and low pressure hoses, relief valve and shaft seal.
- **Liquid tank**
Check the tube fitting.
- **Service valves**
Check all around the service valves. Ensure service valve caps are secured on the service valves (to prevent leaks).

NOTE:

After removing A/C manifold gauge set from service valves, wipe any residue from valves to prevent any false readings by leak detector.

- **Cooling unit (Evaporator)**

With engine OFF, turn blower fan on "High" for at least 15 seconds to dissipate any refrigerant trace in the cooling unit. Wait a minimum of 10 minutes accumulation time (refer to the manufacturer's recommended procedure for actual wait time) before inserting the leak detector probe into the drain hose. Keep the probe inserted for at least ten seconds. Use caution not to contaminate the probe tip with water or dirt that may be in the drain hose.

5. If a leak detector detects a leak, verify at least once by blowing compressed air into area of suspected leak, then repeat check as outlined above.
6. Do not stop when one leak is found. Continue to check for additional leaks at all system components. If no leaks are found, perform steps 7 - 10.
7. Start engine.
8. Set the heater A/C control as follows:
 - 1) A/C switch ON.
 - 2) Face mode
 - 3) Recirculation switch ON
 - 4) Max cold temperature
 - 5) Fan speed high
9. Run engine at 1,500 rpm for at least 2 minutes.
10. Turn engine off and perform leak check again following steps 4 through 6 above.

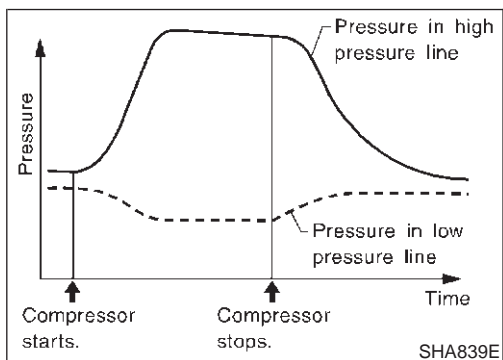

Refrigerant leaks should be checked immediately after stopping the engine. Begin with the leak detector at the compressor. The pressure on the high pressure side will gradually drop after refrigerant circulation stops and pressure on the low pressure side will gradually rise, as shown in the graph. Some leaks are more easily detected when pressure is high.

11. Before connecting ACR4 to vehicle, check ACR4 gauges. No refrigerant pressure should be displayed. If pressure is displayed, recover refrigerant from equipment lines and then check refrigerant purity.
12. Confirm refrigerant purity in supply tank using ACR4 and refrigerant identifier.
13. Confirm refrigerant purity in vehicle A/C system using ACR4 and refrigerant identifier.
14. Discharge A/C system using approved refrigerant recovery equipment. Repair the leaking fitting or component as necessary.

GI
MA
EM
LC
EC
FE
CL
MT
AT
AX
SU
BR
ST
RS
BT
HA

15. Evacuate and recharge A/C system and perform the leak test to confirm no refrigerant leaks.
16. Conduct A/C performance test to ensure system works properly.

Fluorescent Dye Leak Detector

PRECAUTIONS FOR FLUORESCENT DYE LEAK DETECTION

- The fluorescent dye leak detector is not a replacement for an electronic refrigerant leak detector. The fluorescent dye leak detector should be used in conjunction with an electronic refrigerant leak detector (J-41995) to pinpoint refrigerant leaks. NFHA0270
- For your safety and your customer's satisfaction, read and follow all manufacturer's operating instructions and precautions prior to performing the work.
- Refer to "Precautions for Leak Detection Dye", HA-4.

CHECKING SYSTEM FOR LEAKS USING THE FLUORESCENT LEAK DETECTOR

1. Check A/C system for leaks using the UV lamp and goggles (J-42220) in a low sunlight area (area without windows preferable). Illuminate all components, fittings and lines. The dye will appear as a bright green/yellow area at the point of leakage. Fluorescent dye observed at the evaporator drain opening indicates an evaporator core assembly (tubes, core or TXV) leak. NFHA0271
2. If the suspected area is difficult to see, use an adjustable mirror or wipe the area with a clean shop rag or cloth, then check the cloth with the UV lamp for dye residue.
3. Confirm any suspected leaks with an approved electronic refrigerant leak detector.
4. After the leak is repaired, remove any residual dye using dye cleaner (J-43872) to prevent future misdiagnosis.
5. Perform a system performance check and verify the leak repair with an approved electronic refrigerant leak detector.

DYE INJECTION

(This procedure is only necessary when re-charging the system or when the compressor has seized and was replaced.) NFHA0272

Refer to "Precautions for Leak Detection Dye", HA-4.

1. Check A/C system static (at rest) pressure. Pressure must be at least 345 kPa (3.52 kg/cm², 50 psi).
2. Pour one bottle (1/4 ounce / 7.4 cc) of the A/C refrigerant dye into the injector tool (J-41459).
3. Connect the injector tool to the A/C LOW PRESSURE side service fitting.
4. Start engine and switch A/C ON.
5. With the A/C operating (compressor running), inject one bottle (1/4 ounce / 7.4 cc) of fluorescent dye through the low-pressure service valve using dye injector tool J-41459 (refer to the manufacturer's operating instructions).

- With the engine still running, disconnect the injector tool from the service fitting.

CAUTION:

Be careful not to allow dye to spray or drip when disconnecting the injector from the system.

NOTE:

If repairing the A/C system or replacing a component, pour the dye directly into the open system connection and proceed with the service procedures.

- Operate the A/C system for a minimum of 20 minutes to mix the dye with the system oil. Depending on the leak size, operating conditions and location of the leak, it may take from minutes to days for the dye to penetrate a leak and become visible.

GI
MA
EM
LC
EC
FE
CL
MT

Belt

TENSION ADJUSTMENT

- Refer to MA-13, "Checking Drive Belt".

NFHA0237

AT
AX
SU
BR

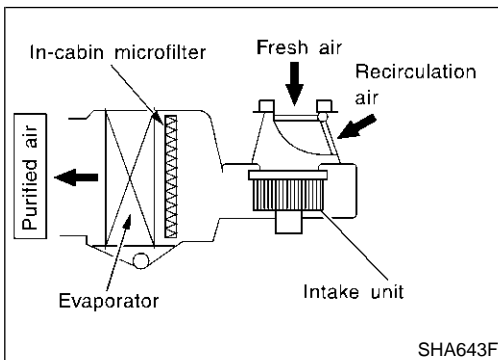

In-cabin Microfilter

FUNCTION

Air inside passenger compartment is kept clean at either recirculation or fresh mode by installing in-cabin microfilter into cooling unit.

NOTE:

For replacement interval of in-cabin microfilter, refer to "PERIODIC MAINTENANCE", MA-6.

Caution label is fixed inside the glove box.

NFHA0286

ST
RS
BT

HA

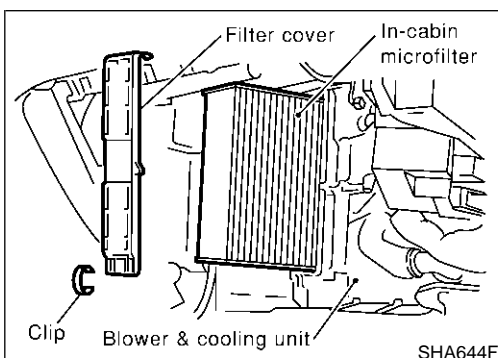

REPLACEMENT PROCEDURE

- Remove glove box.
- Remove instrument lower panel from instrument panel.
- Remove filter cover fixed clip.
- Slide the filter cover to the upper side and then remove it.
- Take out the in-cabin microfilter from cooling unit.
- Replace with new one and reinstall on cooling unit.

NFHA0287

SC
EL
IDX

Auto

Auto

COMPRESSOR

NFHA0241

Model		Calsonic Kansei make V-6
Type		V-6 variable displacement
Displacement cm ³ (cu in)/rev.	Max.	184 (11.228)
	Min.	14.5 (0.885)
Cylinder bore x stroke mm (in)		37 (1.46) x [2.3 - 28.6 (0.091 - 1.126)]
Direction of rotation		Clockwise (viewed from drive end)
Drive belt		Poly V

LUBRICANT

NFHA0242

Model		Calsonic Kansei make V-6
Name		Nissan A/C System Oil Type S
Part number		KLH00-PAGS0
Capacity mℓ (US fl oz, Imp fl oz)	Total in system	180 (6.1, 6.3)
	Compressor (Service part) charging amount	180 (6.1, 6.3)

REFRIGERANT

NFHA0243

Type	HFC-134a (R-134a)
Capacity kg (lb)	0.5 (1.10)

ENGINE IDLING SPEED (WHEN A/C IS ON)

NFHA0244

- Refer to EC-737, "Idle Speed and Ignition Timing".

BELT TENSION

NFHA0245

- Refer to MA-13, "Checking Drive Belts".

Supplemental Restraint System (SRS) "AIR BAG" and "SEAT BELT PRE-TENSIONER"

NFHA0060

The Supplemental Restraint System such as "AIR BAG" and "SEAT BELT PRE-TENSIONER" used along with a seat belt, helps to reduce the risk or severity of injury to the driver and front passenger for certain types of collision. This system includes seat belt switch inputs and dual stage front air bag modules. The SRS system uses the seat belt switches to determine the front air bag deployment, and may only deploy one front air bag, depending on the severity of a collision and whether the front occupants are belted or unbelted. The SRS system composition which is available to NISSAN MODEL A33 is as follows:

- For a frontal collision
The Supplemental Restraint System consists of driver air bag module (located in the center of the steering wheel), front passenger air bag module (located on the instrument panel on passenger side), seat belt pre-tensioners, a diagnosis sensor unit, crash zone sensor, warning lamp, wiring harness and spiral cable.
- For a side collision
The Supplemental Restraint System consists of front side air bag module (located in the outer side of front seat), satellite sensor, diagnosis sensor unit (one of components of air bags for a frontal collision), wiring harness, warning lamp (one of components of air bags for a frontal collision).

Information necessary to service the system safely is included in the **RS section** of this Service Manual.

WARNING:

- To avoid rendering the SRS inoperative, which could increase the risk of personal injury or death in the event of a collision which would result in air bag inflation, all maintenance should be performed by an authorized NISSAN dealer.
- Improper maintenance, including incorrect removal and installation of the SRS, can lead to personal injury caused by unintentional activation of the system. For removal of Spiral Cable and Air Bag Module, see the RS section.
- Do not use electrical test equipment on any circuit related to the SRS unless instructed to in this Service Manual. SRS wiring harnesses can be identified by yellow and/or orange harness connector.

Precautions for Working with HFC-134a (R-134a)

NFHA0061

WARNING:

- CFC-12 (R-12) refrigerant and HFC-134a (R-134a) refrigerant are not compatible. If the refrigerants are mixed and compressor malfunction is likely to occur, refer to "CONTAMINATED REFRIGERANT" below. To determine the purity of HFC-134a (R-134a) in the vehicle and recovery tank, use Refrigerant Recovery/Recycling Recharging equipment (ACR4) (J-39500-NI) and Refrigerant Identifier.
- Use only specified lubricant for the HFC-134a (R-134a) A/C system and HFC-134a (R-134a) components. If lubricant other than that specified is used, compressor failure is likely to occur.
- The specified HFC-134a (R-134a) lubricant rapidly absorbs moisture from the atmosphere. The following handling precautions must be observed:
 - a) When removing refrigerant components from a vehicle, immediately cap (seal) the component to minimize the entry of moisture from the atmosphere.
 - b) When installing refrigerant components to a vehicle, do not remove the caps (unseal) until just before connecting the components. Connect all refrigerant loop components as quickly as possible to minimize the entry of moisture into system.
 - c) Only use the specified lubricant from a sealed container. Immediately reseal containers of lubricant. Without proper sealing, lubricant will become moisture saturated and should not be used.
 - d) Avoid breathing A/C refrigerant and lubricant vapor or mist. Exposure may irritate eyes, nose and throat. Remove HFC-134a (R-134a) from the A/C system, using certified service equipment meeting requirements of SAE J2210 [HFC-134a (R-134a) recycling equipment], or J2209 [HFC-134a (R-134a) recovery equipment]. If accidental system discharge occurs, ventilate work area before resuming service. Additional health and safety information may be obtained from refrigerant and lubricant manufacturers.
 - e) Do not allow lubricant (Nissan A/C System Oil Type S) to come in contact with styrofoam parts. Damage may result.

CONTAMINATED REFRIGERANT

If a refrigerant other than pure HFC-134a (R-134a) is identified in a vehicle, your options are:

NFHA0061S01

GI
MA
EM
LC
EC
FE
CL
MT
AT
AX
SU
BR
ST
RS
BT
HA
SC
EL
IDX

Precautions for Working with HFC-134a (R-134a) (Cont'd)

- Explain to the customer that environmental regulations prohibit the release of contaminated refrigerant into the atmosphere.
- Explain that recovery of the contaminated refrigerant could damage your service equipment and refrigerant supply.
- Suggest the customer return the vehicle to the location of previous service where the contamination may have occurred.
- If you choose to perform the repair, recover the refrigerant using only **dedicated equipment and containers. Do not recover contaminated refrigerant into your existing service equipment.** If your facility does not have dedicated recovery equipment, you may contact a local refrigerant product retailer for available service. This refrigerant must be disposed of in accordance with all federal and local regulations. In addition, replacement of all refrigerant system components on the vehicle is recommended.
- If the vehicle is within the warranty period, the air conditioner warranty is void. Please contact Nissan Customer Affairs for further assistance.

General Refrigerant Precautions

NFHA0062

WARNING:

- **Do not release refrigerant into the air. Use approved recovery/recycling equipment to capture the refrigerant every time an air conditioning system is discharged.**
- **Always wear eye and hand protection (goggles and gloves) when working with any refrigerant or air conditioning system.**
- **Do not store or heat refrigerant containers above 52°C (125°F).**
- **Do not heat a refrigerant container with an open flame; if container warming is required, place the bottom of the container in a warm pail of water.**
- **Do not intentionally drop, puncture, or incinerate refrigerant containers.**
- **Keep refrigerant away from open flames: poisonous gas will be produced if refrigerant burns.**
- **Refrigerant will displace oxygen, therefore be certain to work in well ventilated areas to prevent suffocation.**
- **Do not pressure test or leak test HFC-134a (R-134a) service equipment and/or vehicle air conditioning systems with compressed air during repair. Some mixtures of air and R-134a have been shown to be combustible at elevated pressures. These mixtures, if ignited, may cause injury or property damage. Additional health and safety information may be obtained from refrigerant manufacturers.**

Precautions for Leak Detection Dye

NFHA0273

- The A/C system contains a fluorescent leak detection dye used for locating refrigerant leaks. An ultraviolet (UV) lamp is required to illuminate the dye when inspecting for leaks.
- Always wear fluorescence enhancing UV goggles to protect your eyes and enhance the visibility of the fluorescent dye.
- A compressor shaft seal should not be repaired because of dye seepage. The compressor shaft seal should only be repaired after confirming the leak with an electronic refrigerant leak detector (J-41995).
- Always remove any dye from the leak area after repairs are complete to avoid a misdiagnosis during a future service.
- Do not allow dye to come into contact with painted body panels or interior components. If dye is spilled, clean immediately with the approved dye cleaner. Fluorescent dye left on a surface for an extended period of time cannot be removed.
- Do not spray the fluorescent dye cleaning agent on hot surfaces (engine exhaust manifold, etc.).
- Do not use more than one refrigerant dye bottle (1/4 ounce /7.4 cc) per A/C system.
- Leak detection dyes for HFC-134a (R-134a) and CFC-12 (R-12) A/C systems are different. Do not use HFC-134a (R-134a) leak detection dye in CFC-12 (R-12) A/C system or CFC-12 (R-12) leak detection dye in HFC-134a (R-134a) A/C systems or A/C system damage may result.
- The fluorescent properties of the dye will remain for over three (3) years unless a compressor malfunction occurs.

AIR CONDITIONER NISSAN		
REFRIGERANT	COMPRESSOR LUBRICANT	
TYPE (PART NO.)	HFC134a (R134a)	Nissan UV Luminous Oil Type S [KLHOO-PAGSO]
AMOUNT		
<p>CAUTION PRECAUTION</p> <ul style="list-style-type: none"> REFRIGERANT UNDER HIGH PRESSURE. SYSTEM TO BE SERVICED BY QUALIFIED PERSONNEL. IMPROPER SERVICE METHODS MAY CAUSE PERSONAL INJURY. CONSULT SERVICE MANUAL. THIS AIR CONDITIONER SYSTEM COMPLIES WITH SAE J-639. <p>Nissan Motor Co., Ltd., TOKYO, Japan 27090 6P102</p>		
SHA436FA		

Precaution for Identification Label on Vehicle

NFHA0274

- Vehicles with factory installed fluorescent dye have this identification label on the under side of hood.
- Vehicles with factory installed fluorescent dye have a green label.
- Vehicles without factory installed fluorescent dye have a blue label.

GI
MA
EM
LC

Precautions for Refrigerant Connection

NFHA0063

A new type refrigerant connection has been introduced to all refrigerant lines except the following portion.

- Expansion valve to evaporator

FEATURES OF NEW TYPE REFRIGERANT CONNECTION

- The O-ring has been relocated. It has also been provided with a groove for proper installation. This eliminates the chance of the O-ring being caught in, or damaged by, the mating part. The sealing direction of the O-ring is now set vertically in relation to the contacting surface of the mating part to improve sealing characteristics.
- The reaction force of the O-ring will not occur in the direction that causes the joint to pull out, thereby facilitating piping connections.

EC
FE
CL
MT

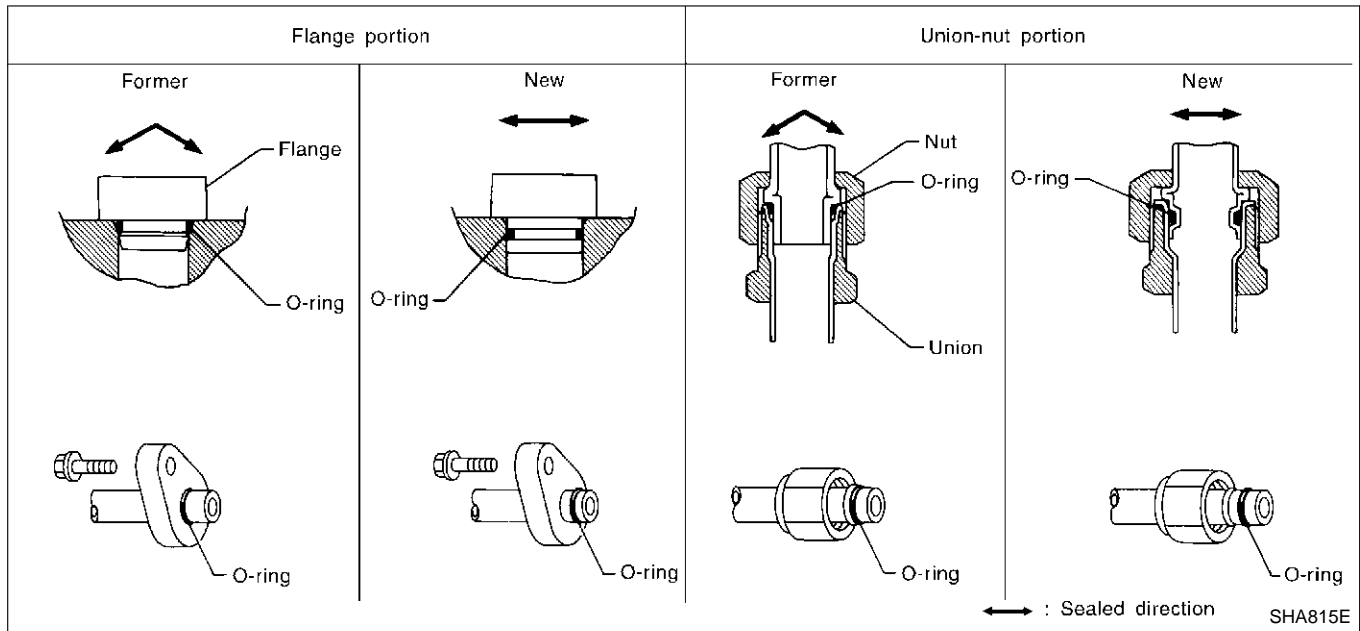

AT
AX
SU
BR
ST
RS
BT

HA

SC

EL

IDX

O-RING AND REFRIGERANT CONNECTION

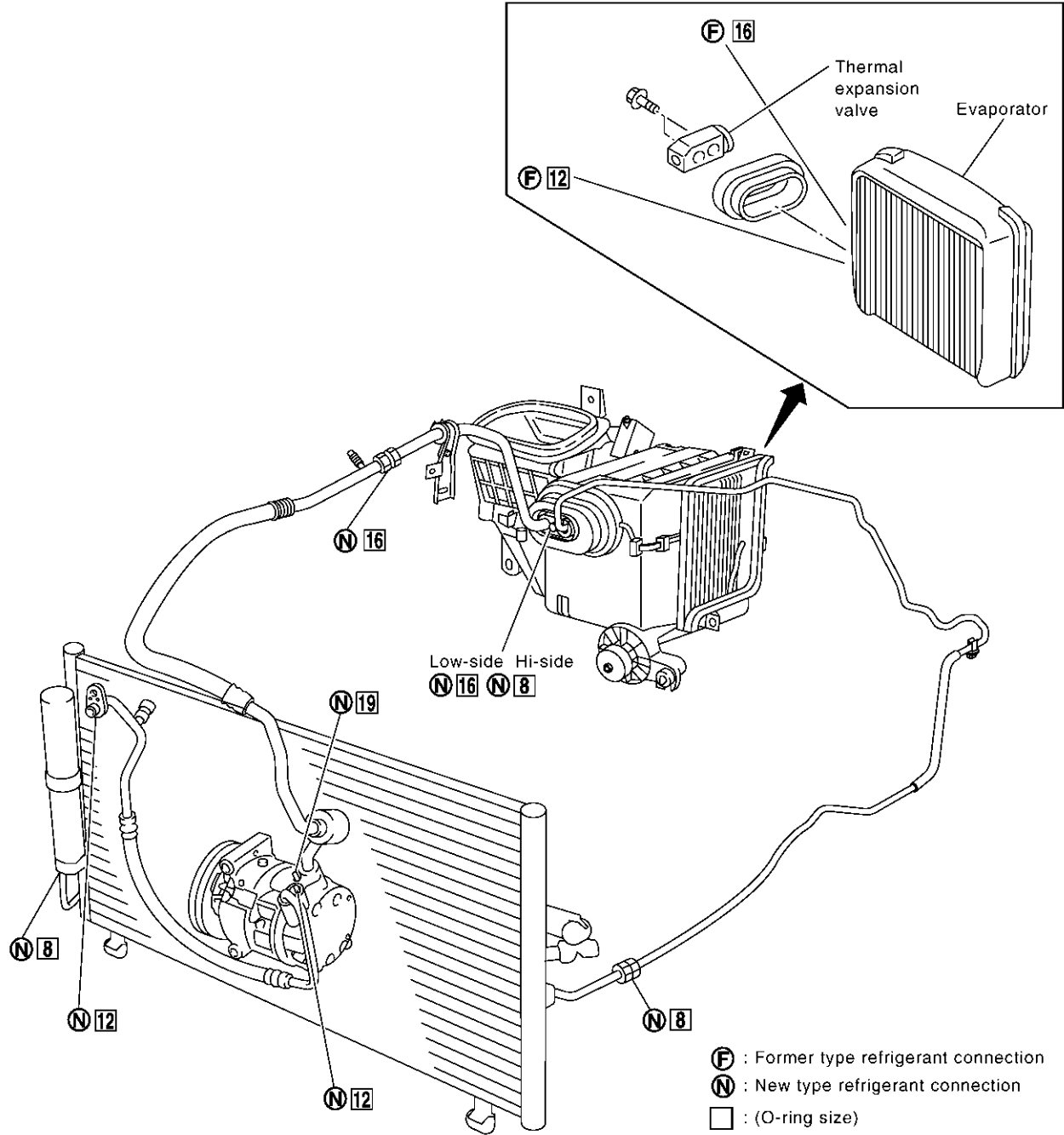

RHA0301

CAUTION:

The new and former refrigerant connections use different O-ring configurations. Do not confuse O-rings since they are not interchangeable. If a wrong O-ring is installed, refrigerant will leak at, or around, the connection.

O-Ring Part Numbers and Specifications

NFHA0063S0201

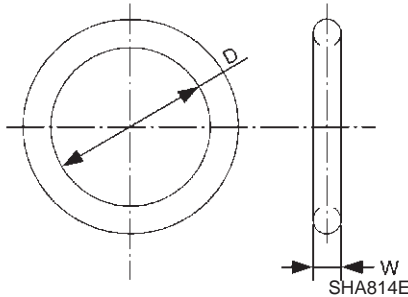

Connection type	O-ring size	Part number	D mm (in)	W mm (in)
New	8	92471 N8210	6.8 (0.268)	1.85 (0.0728)
Former		92470 N8200	6.07 (0.2390)	1.78 (0.0701)
New	12	92472 N8210	10.9 (0.429)	2.43 (0.0957)
Former		92475 71L00	11.0 (0.433)	2.4 (0.094)
New	16	92473 N8210	13.6 (0.535)	2.43 (0.0957)
Former		92475 72L00	14.3 (0.563)	2.3 (0.091)
New	19	92474 N8210	16.5 (0.650)	2.43 (0.0957)
Former		92477 N8200	17.12 (0.6740)	1.78 (0.0701)

WARNING:

Make sure all refrigerant is discharged into the recycling equipment and the pressure in the system is less than atmospheric pressure. Then gradually loosen the discharge side hose fitting and remove it.

CAUTION:

When replacing or cleaning refrigerant cycle components, observe the following.

- When the compressor is removed, store it in the same position as it is when mounted on the car. Failure to do so will cause lubricant to enter the low pressure chamber.
- When connecting tubes, always use a torque wrench and a back-up wrench.
- After disconnecting tubes, immediately plug all openings to prevent entry of dirt and moisture.
- When installing an air conditioner in the vehicle, connect the pipes as the final stage of the operation. Do not remove the seal caps of pipes and other components until just before required for connection.
- Allow components stored in cool areas to warm to working area temperature before removing seal caps. This prevents condensation from forming inside A/C components.
- Thoroughly remove moisture from the refrigeration system before charging the refrigerant.
- Always replace used O-rings.
- When connecting tube, apply lubricant to circle of the O-rings shown in illustration. Be careful not to apply lubricant to threaded portion.
Lubricant name: Nissan A/C System Oil Type S
Part number: KLH00-PAGS0
- O-ring must be closely attached to dented portion of tube.
- When replacing the O-ring, be careful not to damage O-ring and tube.
- Connect tube until you hear it click, then tighten the nut or bolt by hand until snug. Make sure that the O-ring is installed to tube correctly.
- After connecting line, conduct leak test and make sure that there is no leakage from connections. When the gas leaking point is found, disconnect that line and replace the O-ring. Then tighten connections of seal seat to the specified torque.

GI
MA
EM
LG
EC
FE
CL
MT
AT
AX
SU
BR
ST
RS
BT
HA
SC
EL
IDX

Precautions for Refrigerant Connection (Cont'd)

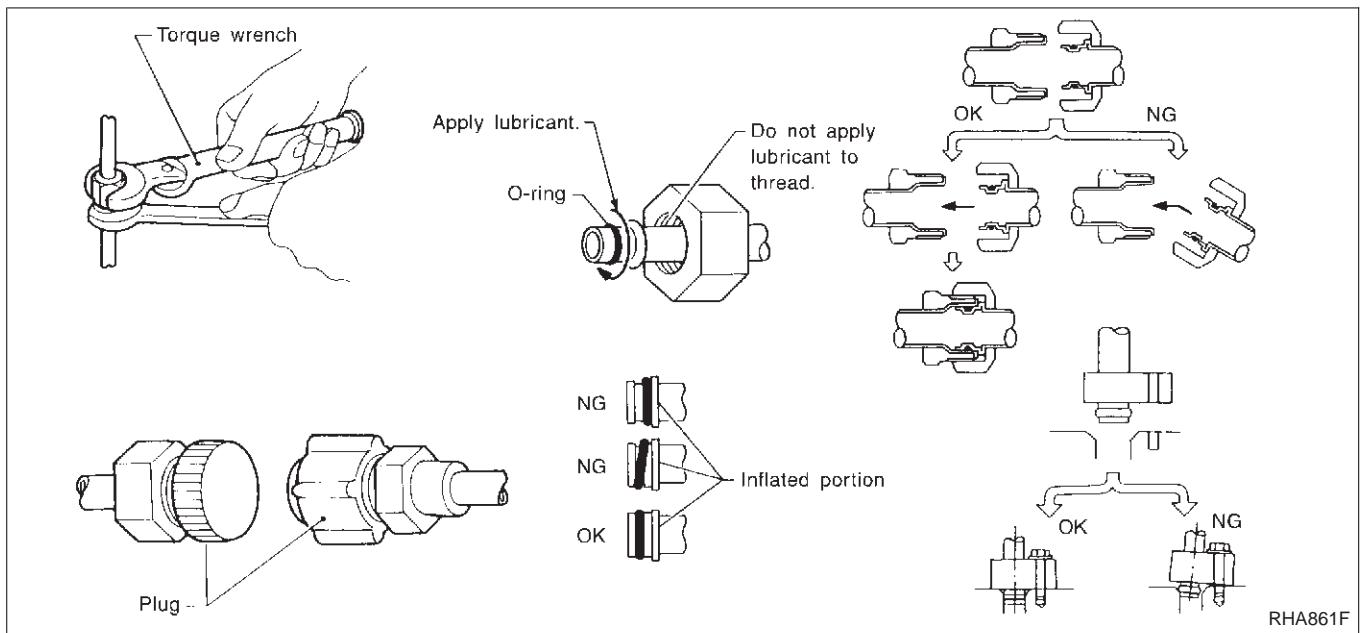

Precautions for Servicing Compressor

NFHA0064

- Plug all openings to prevent moisture and foreign matter from entering.
- When the compressor is removed, store it in the same position as it is when mounted on the car.
- When replacing or repairing compressor, follow “Maintenance of Lubricant Quantity in Compressor” exactly. Refer to HA-227.
- Keep friction surfaces between clutch and pulley clean. If the surface is contaminated, with lubricant, wipe it off by using a clean waste cloth moistened with thinner.
- After compressor service operation, turn the compressor shaft by hand more than five turns in both directions. This will equally distribute lubricant inside the compressor. After the compressor is installed, let the engine idle and operate the compressor for one hour.
- After replacing the compressor magnet clutch, apply voltage to the new one and check for normal operation.

Precautions for Service Equipment
RECOVERY/RECYCLING EQUIPMENT

NFHA0065

NFHA0065S01

Follow the manufacturer’s instructions for machine operation and machine maintenance. Never introduce any refrigerant other than that specified into the machine.

ELECTRONIC LEAK DETECTOR

NFHA0065S02

Follow the manufacture’s instructions for tester operation and tester maintenance.

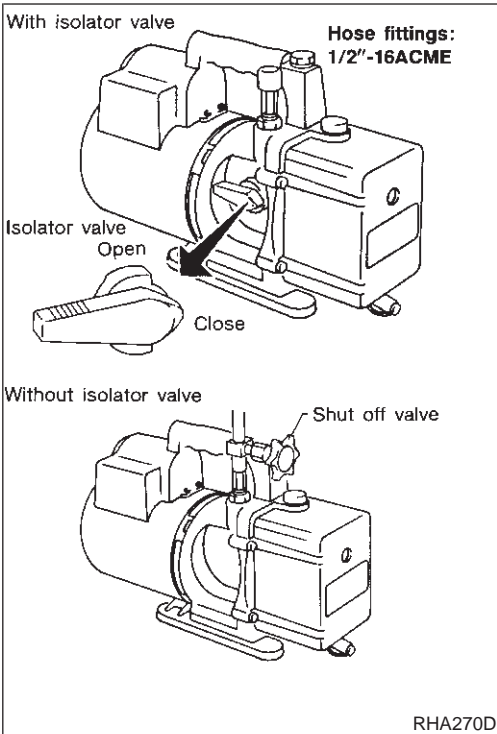

VACUUM PUMP

NFHA0065S03

The lubricant contained inside the vacuum pump is not compatible with the specified lubricant for HFC-134a (R-134a) A/C systems. The vent side of the vacuum pump is exposed to atmospheric pressure. So the vacuum pump lubricant may migrate out of the pump into the service hose. This is possible when the pump is switched off after evacuation (vacuuming) and hose is connected to it.

To prevent this migration, use a manual valve situated near the hose-to-pump connection, as follows.

- Usually vacuum pumps have a manual isolator valve as part of the pump. Close this valve to isolate the service hose from the pump.
- For pumps without an isolator, use a hose equipped with a manual shut-off valve near the pump end. Close the valve to isolate the hose from the pump.
- If the hose has an automatic shut off valve, disconnect the hose from the pump: as long as the hose is connected, the valve is open and lubricating oil may migrate.

Some one-way valves open when vacuum is applied and close under a no vacuum condition. Such valves may restrict the pump's ability to pull a deep vacuum and are not recommended.

MANIFOLD GAUGE SET

NFHA0065S04

Be certain that the gauge face indicates R-134a. Make sure the gauge set has 1/2"-16 ACME threaded connections for service hoses. Confirm the set has been used only with refrigerant HFC-134a (R-134a) along with specified lubricant.

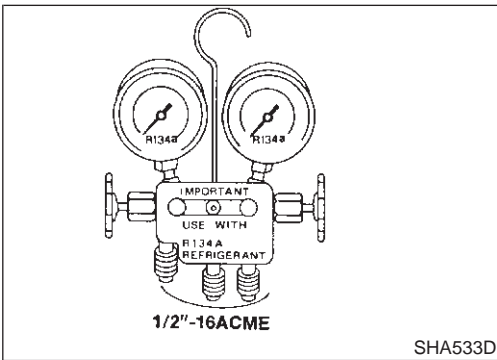

SERVICE HOSES

NFHA0065S05

Be certain that the service hoses display the markings described (colored hose with black stripe). All hoses must include positive shut off devices (either manual or automatic) near the end of the hoses opposite the manifold gauge.

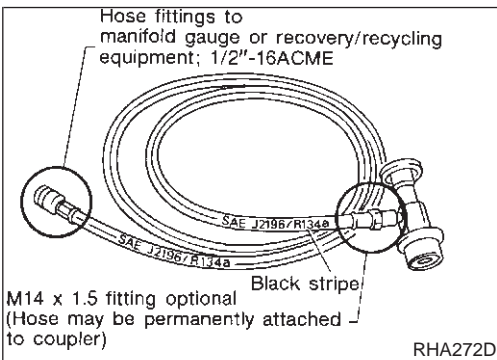

SERVICE COUPLERS

NFHA0065S06

Never attempt to connect HFC-134a (R-134a) service couplers to an CFC-12 (R-12) A/C system. The HFC-134a (R-134a) couplers will not properly connect to the CFC-12 (R-12) system. However, if an improper connection is attempted, discharging and contamination may occur.

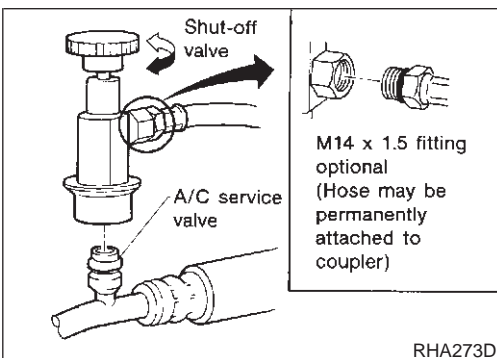

Shut-off valve rotation	A/C service valve
Clockwise	Open
Counterclockwise	Close

GI
MA
EM
LC
EC
FE
CL
MT
AT
AX
SU
BR
ST
RS
BT
HA
SC
EL
IDX

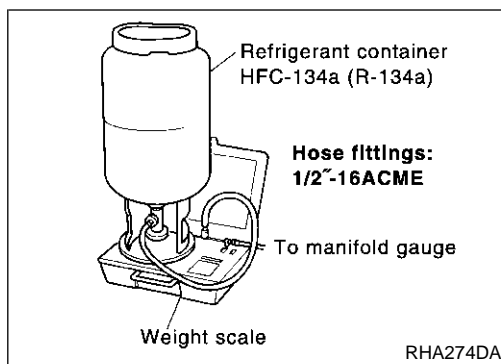

REFRIGERANT WEIGHT SCALE

NFHA0065S07

Verify that no refrigerant other than HFC-134a (R-134a) and specified lubricants have been used with the scale. If the scale controls refrigerant flow electronically, the hose fitting must be 1/2"-16 ACME.

CALIBRATING ACR4 WEIGHT SCALE

NFHA0065S09

Calibrate the scale every three months.

To calibrate the weight scale on the ACR4 (J-39500-NI):

1. Press **Shift/Reset** and **Enter** at the same time.
2. Press **8787**. "A1" will be displayed.
3. Remove all weight from the scale.
4. Press **0**, then press **Enter**. "0.00" will be displayed and change to "A2".
5. Place a known weight (dumbbell or similar weight), between 4.5 and 8.6 kg (10 and 19 lb) on the center of the weight scale.
6. Enter the known weight using four digits. (Example 10 lb = 10.00, 10.5 lb = 10.50)
7. Press **Enter** — the display returns to the vacuum mode.
8. Press **Shift/Reset** and **Enter** at the same time.
9. Press **6** — the known weight on the scale is displayed.
10. Remove the known weight from the scale. "0.00" will be displayed.
11. Press **Shift/Reset** to return the ACR4 to the program mode.

CHARGING CYLINDER

NFHA0065S08

Using a charging cylinder is not recommended. Refrigerant may be vented into air from cylinder's top valve when filling the cylinder with refrigerant. Also, the accuracy of the cylinder is generally less than that of an electronic scale or of quality recycle/recharge equipment.

Wiring Diagrams and Trouble Diagnosis

NFHA0066

When you read wiring diagrams, refer to the following:

- GI-11, "HOW TO READ WIRING DIAGRAMS" in GI section
- EL-12, "Wiring Diagram — POWER —" for power distribution circuit in EL section

When you perform trouble diagnosis, refer to the following:

- GI-35, "HOW TO FOLLOW TEST GROUPS IN TROUBLE DIAGNOSES" in GI section
- GI-24, "HOW TO PERFORM EFFICIENT DIAGNOSIS FOR AN ELECTRICAL INCIDENT" in GI section

Special Service Tools

NFHA0067

The actual shapes of Kent-Moore tools may differ from those of special service tools illustrated here.

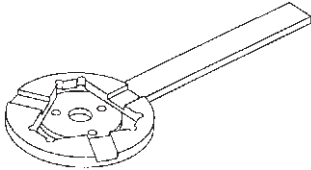
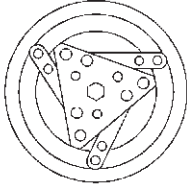
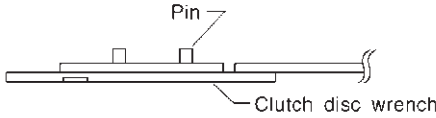
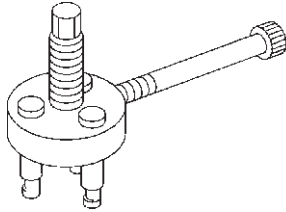
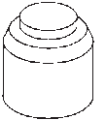
Tool number (Kent-Moore No.) Tool name	Description	
KV99106100 (J-41260) Clutch disc wrench	 <p>NT232</p>  <p>When replacing the magnet clutch in the above compressor, use a clutch disc wrench with the pin side on the clutch disc to remove it.</p>  <p>Pin Clutch disc wrench</p> <p>NT378</p>	GI MA EM LC EC FE CL MT AT AX
KV99232340 (J-38874) or KV992T0001 (—) Clutch disc puller	 <p>NT376</p>	Removing clutch disc SU BR ST
KV99106200 (J-41261) Pulley installer	 <p>NT235</p>	Installing pulley RS BT

HA

SC

EL

IDX

HFC-134a (R-134a) Service Tools and Equipment



=NFHA0068

Never mix HFC-134a (R-134a) refrigerant and/or its specified lubricant with CFC-12 (R-12) refrigerant and/or its lubricant.

Separate and non-interchangeable service equipment must be used for handling each type of refrigerant/lubricant.

Refrigerant container fittings, service hose fittings and service equipment fittings (equipment which handles refrigerant and/or lubricant) are different between CFC-12 (R-12) and HFC-134a (R-134a). This is to avoid mixed use of the refrigerants/lubricant.

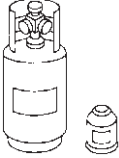

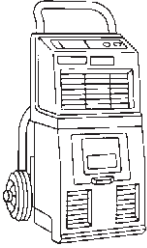
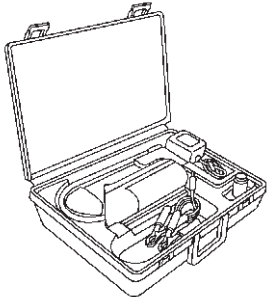
Adapters that convert one size fitting to another must never be used: refrigerant/lubricant contamination will occur and compressor malfunction will result.

Tool number (Kent-Moore No.) Tool name	Description
HFC-134a (R-134a) refrigerant	 <p>Container color: Light blue Container marking: HFC-134a (R-134a) Fitting size: Thread size</p> <ul style="list-style-type: none"> ● large container 1/2"-16 ACME <p>NT196</p>
KLH00-PAGS0 (—) Nissan A/C System Oil Type S	 <p>Type: Poly alkylene glycol oil (PAG), type S Application: HFC-134a (R-134a) swash plate (piston) compressors (Nissan only) Lubricity: 40 mℓ (1.4 US fl oz, 1.4 Imp fl oz)</p> <p>NT197</p>
(J-39500-NI) Recovery/Recycling Recharging equipment (ACR4)	 <p>Function: Refrigerant Recovery and Recycling and Recharging</p> <p>NT195</p>
(J-41995) Electrical leak detector	 <p>Power supply:</p> <ul style="list-style-type: none"> ● DC 12V (Cigarette lighter) <p>AHA281A</p>

PREPARATION

MANUAL

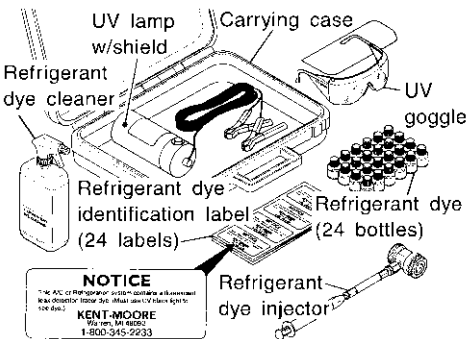
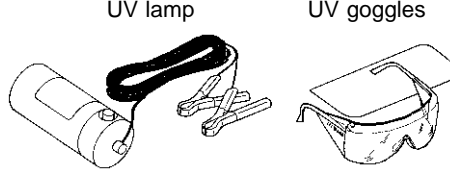
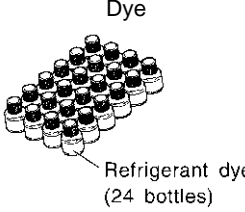
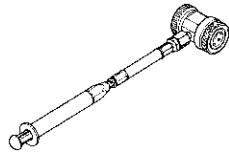

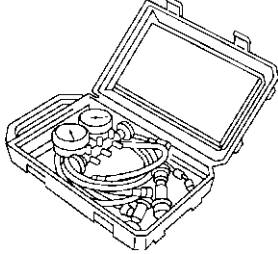
HFC-134a (R-134a) Service Tools and Equipment (Cont'd)

Tool number (Kent-Moore No.) Tool name	Description		
(J-43926) Refrigerant dye leak detection kit Kit includes: (J-42220) UV lamp and UV goggles (J-41459) Refrigerant dye injector (J-41447) qty. 24 HFC-134a (R-134a) refrigerant dye (J-43872) Refrigerant dye cleaner	 <p>UV lamp w/shield Carrying case Refrigerant dye cleaner UV goggles Refrigerant dye identification label (24 labels) Refrigerant dye (24 bottles) Refrigerant dye injector</p> <p>NOTICE The A/C or Refrigerant system contains a flammable gas detector (R134a). Always use UV filter spray (see label). KENT-MOORE Tools, Inc. 2002 1-800-345-2233</p>	Power supply: DC 12V (Battery terminal)	GI MA EM LC EC
(J-42220) Fluorescent dye leak detector	 <p>UV lamp UV goggles</p>	Power supply: DC12V (Battery terminal) For checking refrigerant leak when fluorescent dye is installed in A/C system. Includes: UV lamp and UV goggles	FE CL MT
(J-41447) HFC-134a (R-134a) Fluorescent Leak Detection Dye (Box of 24, 1/4 ounce bottles)	 <p>Dye Refrigerant dye (24 bottles)</p>	Application: For HFC-134a (R-134a) PAG oil Container: 1/4 ounce (7.4 cc) bottle (Includes self-adhesive dye identification labels for affixing to vehicle after charging system with dye.)	AT AX SU
(J-41459) HFC-134a (R-134a) Dye Injector Use with J-41447, 1/4 ounce bottle	 <p>Dye injector</p>	For injecting 1/4 ounce of Fluorescent Leak Detection Dye into A/C system.	BR ST RS
(J-43872) Dye cleaner		For cleaning dye spills.	HA
(J-39183) Manifold gauge set (with hoses and couplers)		Identification: • The gauge face indicates HFC-134a (R-134a). Fitting size: Thread size • 1/2"-16 ACME	SC EL IDX

PREPARATION

MANUAL

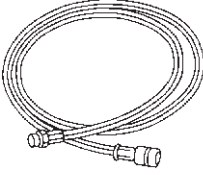
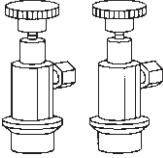
HFC-134a (R-134a) Service Tools and Equipment (Cont'd)

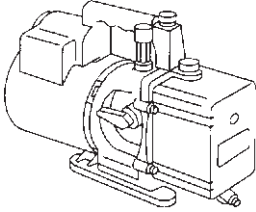
Tool number (Kent-Moore No.) Tool name	Description	
Service hoses <ul style="list-style-type: none"> ● High side hose (J-39501-72) ● Low side hose (J-39502-72) ● Utility hose (J-39476-72) 		Hose color: <ul style="list-style-type: none"> ● Low hose: Blue with black stripe ● High hose: Red with black stripe ● Utility hose: Yellow with black stripe or green with black stripe Hose fitting to gauge: <ul style="list-style-type: none"> ● 1/2"-16 ACME
Service couplers <ul style="list-style-type: none"> ● High side coupler (J-39500-20) ● Low side coupler (J-39500-24) 		Hose fitting to service hose: <ul style="list-style-type: none"> ● M14 x 1.5 fitting is optional or permanently attached.
(J-39650) Refrigerant weight scale		For measuring of refrigerant Fitting size: Thread size <ul style="list-style-type: none"> ● 1/2"-16 ACME
(J-39649) Vacuum pump (Including the isolator valve)		Capacity: <ul style="list-style-type: none"> ● Air displacement: 4 CFM ● Micron rating: 20 microns ● Oil capacity: 482 g (17 oz) Fitting size: Thread size <ul style="list-style-type: none"> ● 1/2"-16 ACME

COMMERCIAL SERVICE TOOL

NFHA0068S01

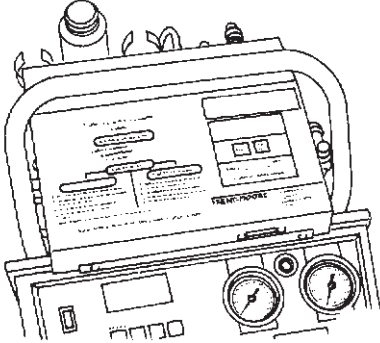
Tool name	Description	
Refrigerant identifier equipment		For checking refrigerant purity and for system contamination

Refrigeration System

REFRIGERATION CYCLE

Refrigerant Flow

The refrigerant flows in the standard pattern, that is, through the compressor, the condenser, the liquid tank, through the evaporator, and back to the compressor. The refrigerant evaporation through the evaporator coil is controlled by an externally equalized expansion valve, located inside the evaporator case.

Freeze Protection

Under normal operating conditions, when the A/C is switched on, the compressor runs continuously, and the evaporator pressure, and therefore, temperature is controlled by the V-6 variable displacement compressor to prevent freeze up.

Refrigerant System Protection

Refrigerant Pressure Sensor

The refrigerant system is protected against excessively high or low pressures by the refrigerant pressure sensor, located on the condenser. If the system pressure rises above, or falls below the specifications, the refrigerant pressure sensor detects the pressure inside the refrigerant line and sends the voltage signal to the ECM. ECM makes the A/C relay go OFF and stops the compressor when pressure on the high pressure side detected by refrigerant pressure sensor is over about 2,746 kPa (28 kg/cm², 398 psi) or below about 177 kPa (1.8 kg/cm², 26 psi).

Pressure Relief Valve

The refrigerant system is also protected by a pressure relief valve, located in the rear head of the compressor. When the pressure of refrigerant in the system increases to an unusual level [more than 3,727 kPa (38 kg/cm², 540 psi)], the release port on the pressure relief valve automatically opens and releases refrigerant into the atmosphere.

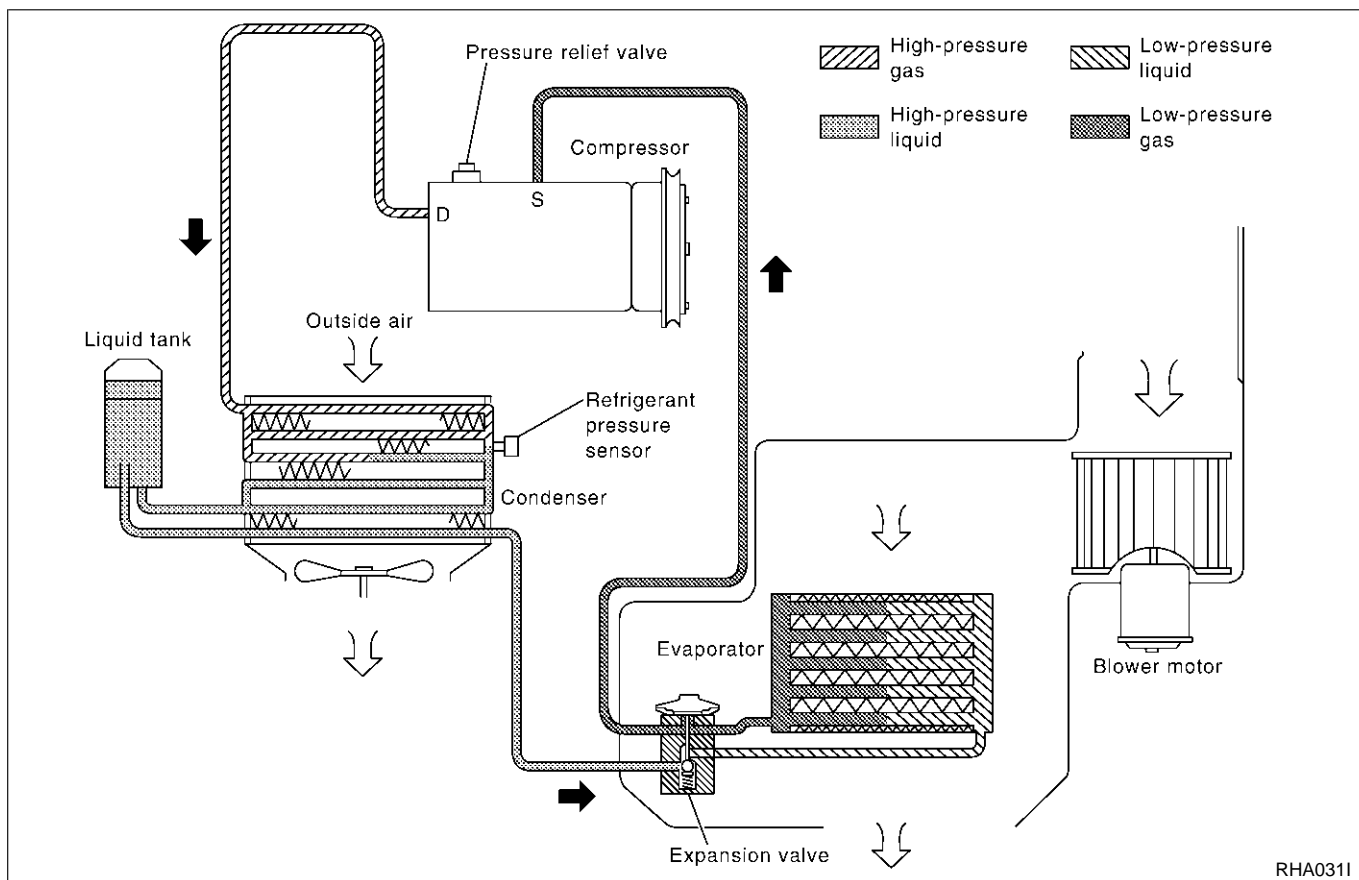

V-6 Variable Displacement Compressor

GENERAL INFORMATION

1. The V-6 variable compressor differs from previous units. The vent temperatures of the V-6 variable compressor do not drop too far below 5°C (41°F) when:
 - evaporator intake air temperature is less than 20°C (68°F)
 - engine is running at speeds less than 1,500 rpm.This is because the V-6 compressor provides a means of “capacity” control.
2. The V-6 variable compressor provides refrigerant control under varying conditions. During cold winters, it may not produce high refrigerant pressure discharge (compared to previous units) when used with air conditioning systems.
3. A “clanking” sound may occasionally be heard during refrigerant charge. The sound indicates that the tilt angle of the swash plate has changed and is not a problem.
4. For air conditioning systems with the V-6 compressor, the clutch remains engaged unless: the system main switch, fan switch or ignition switch is turned OFF. When ambient (outside) temperatures are low or when the amount of refrigerant is insufficient, the clutch is disengaged to protect the compressor.
5. A constant range of suction pressure is maintained when engine speed is greater than a certain value. It normally ranges from 147 to 177 kPa (1.5 to 1.8 kg/cm², 21 to 26 psi) under varying conditions. In previous compressors, however, suction pressure was reduced with increases in engine speed.

=NFHA0070

=NFHA0132

NFHA0132S01

DESCRIPTION

General

The variable compressor is basically a swash plate type that changes piston stroke in response to the required cooling capacity.

The tilt of the swash plate allows the piston's stroke to change so that refrigerant discharge can be continuously changed from 14.5 to 184 cm³ (0.885 to 11.228 cu in).

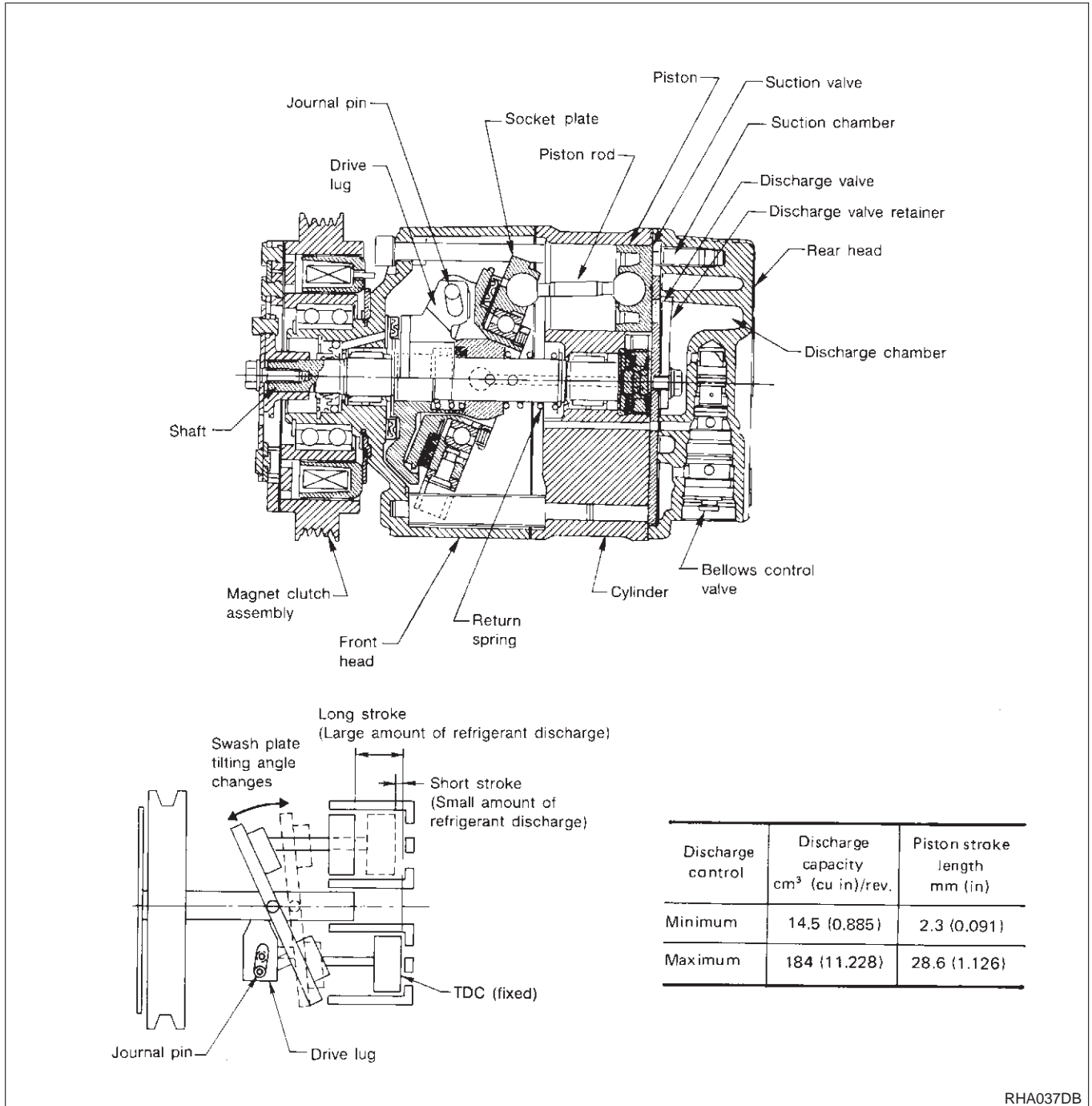

RHA037DB

GI
MA
EM
LC
EC
FE
CL
MT
AT
AX
SU
BR
ST
RS
BT
HA
SC
EL
IDX

Operation

=NFHA0132S02

1. Operation Control Valve

NFHA0132S0201

Operation control valve is located in the suction port (low-pressure) side, and opens or closes in response to changes in refrigerant suction pressure.

Operation of the valve controls the internal pressure of the crankcase.

The angle of the swash plate is controlled between the crankcase's internal pressure and the piston cylinder pressure.

2. Maximum Cooling

NFHA0132S0202

Refrigerant pressure on the low-pressure side increases with an increase in heat loads.

When this occurs, the control valve's bellows compress to open the low-pressure side valve and close the high-pressure side valve.

This causes the following pressure changes:

- the crankcase's internal pressure to equal the pressure on the low-pressure side;
- the cylinder's internal pressure to be greater than the crankcase's internal pressure.

Under this condition, the swash plate is set to the maximum stroke position.

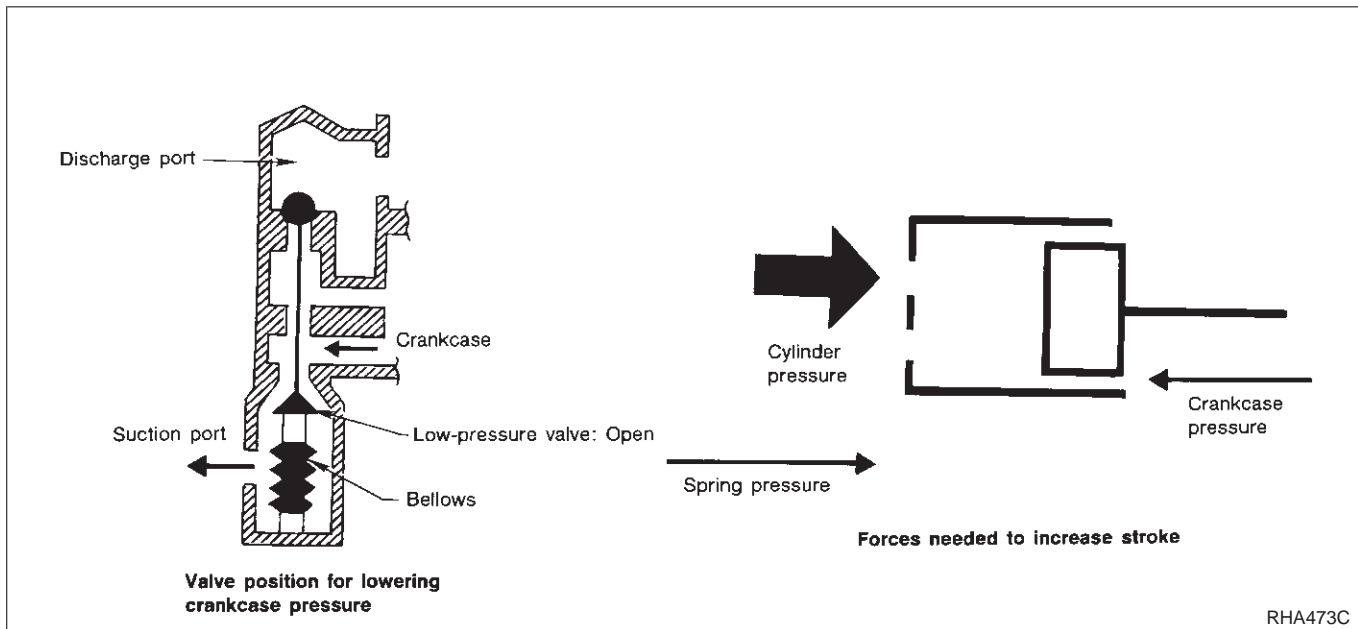

RHA473C

=NFHA0132S0203

3. Capacity Control

- Refrigerant pressure on suction side is low during high speed driving or when ambient or interior temperature is low.
- The bellows expands when refrigerant pressure on the suction pressure side drops below approximately 177 kPa (1.8 kg/cm², 26 psi).

Since suction pressure is low, it makes the suction port close and the discharge port open. Thus, crankcase pressure becomes high as high pressure enters the crankcase.

- The force acts around the journal pin near the swash plate, and is generated by the pressure difference before and behind the piston.

The drive lug and journal pin are located where the piston generates the highest pressure. Piston pressure is between suction pressure P_s and discharge pressure P_d , which is near suction pressure P_s . If crankcase pressure P_c rises due to capacity control, the force around the journal pin makes the swash plate angle decrease and also the piston stroke decrease. In other words, crankcase pressure increase triggers pressure difference between the piston and the crankcase. The pressure difference changes the angle of the swash plate.

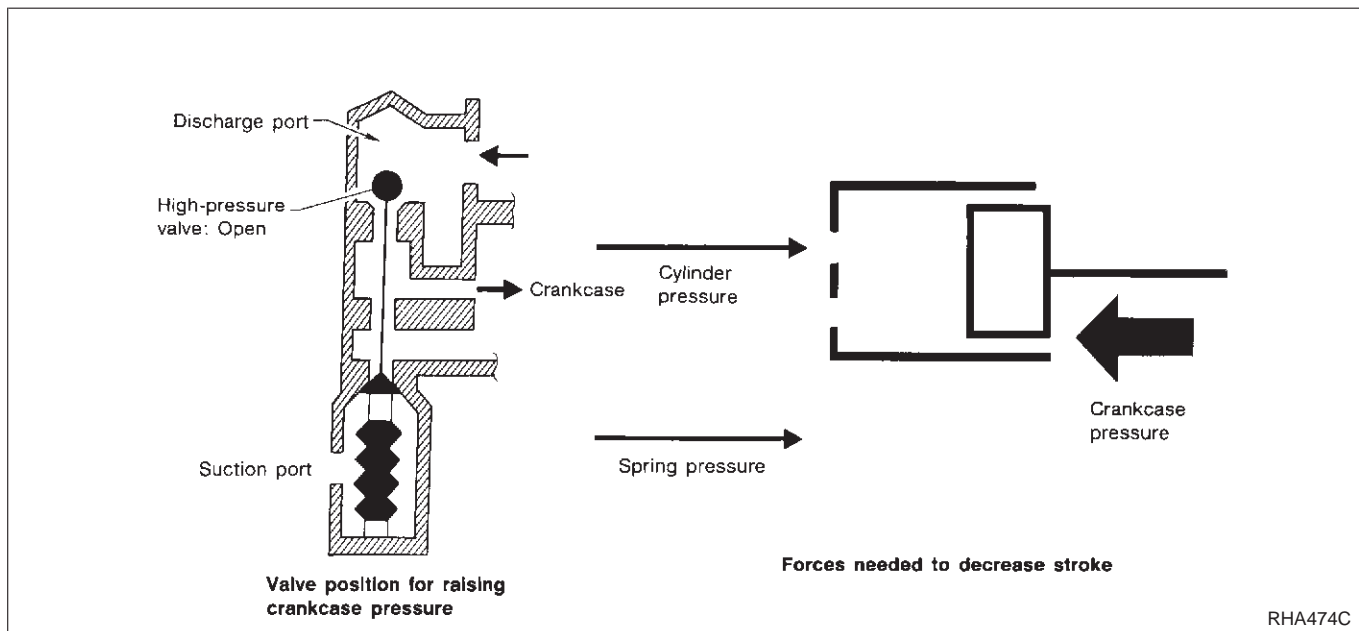

RHA474C

Component Layout

NFHA0071

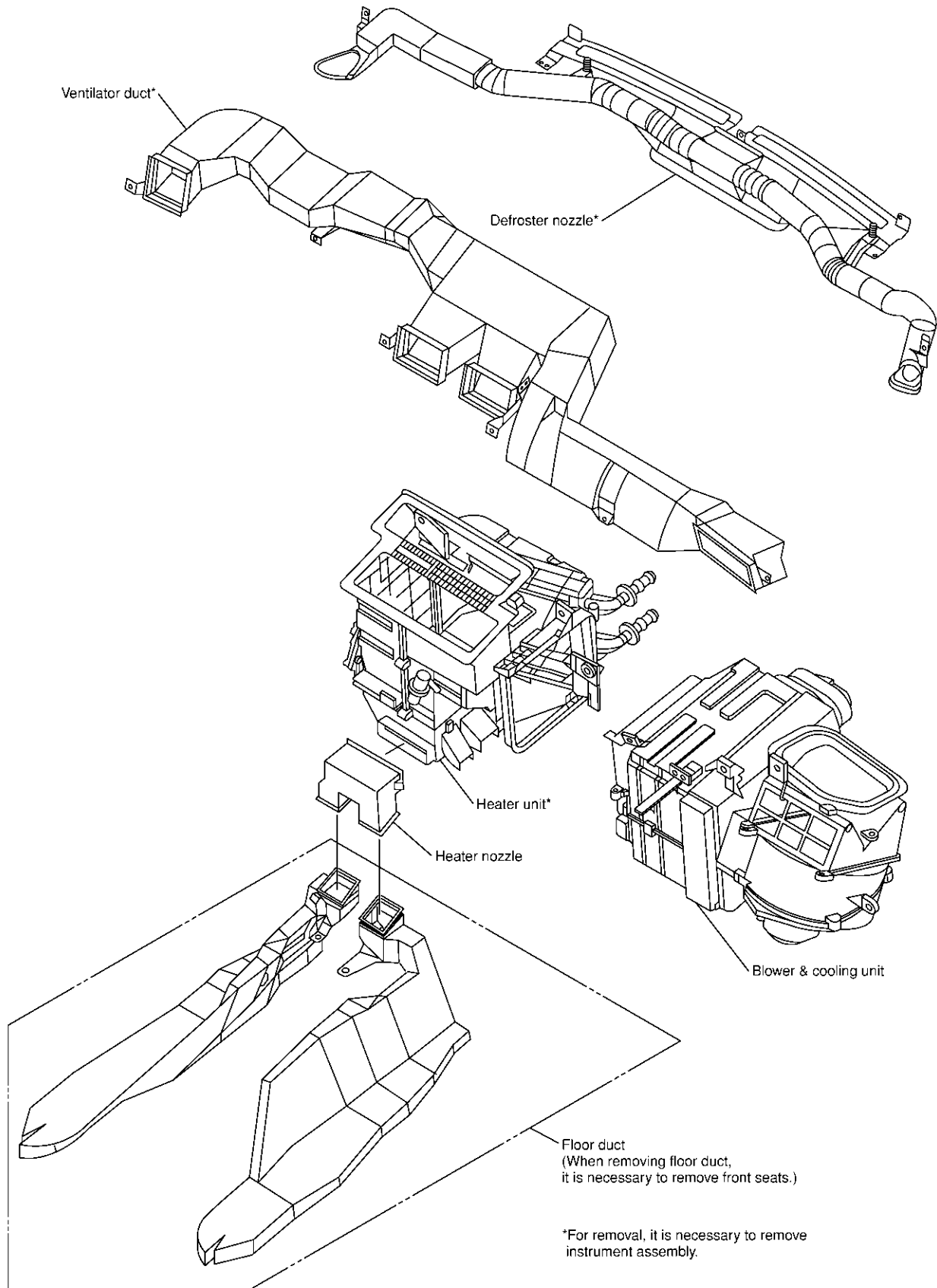

RHA349H

Control Operation

NFHA0072

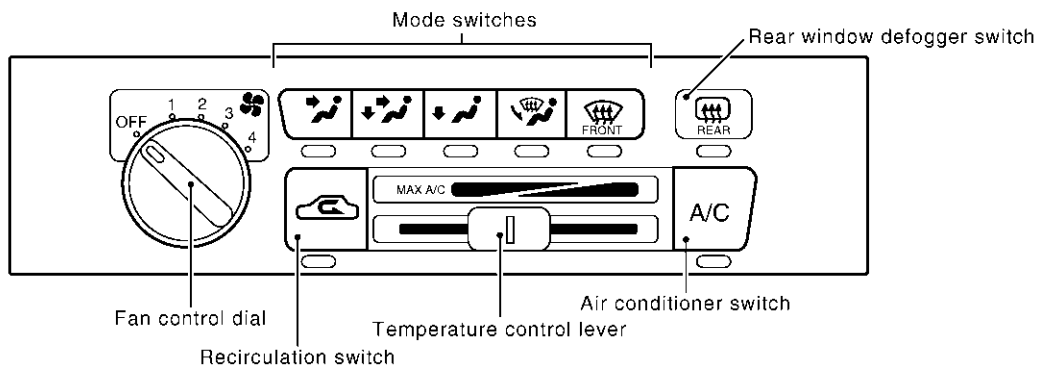

RHA985H

FAN CONTROL DIAL

This dial turns the fan ON and OFF, and controls fan speed.

NFHA0072S01

MODE SWITCHES

This switch allows control of the outlet air flow.

In "DEF", "D/F" or "FOOT" mode, the intake door is set to "FRESH".
The compressor turns on when the Mode switch is moved to "DEF".

NFHA0072S02

TEMPERATURE CONTROL LEVER

This lever allows adjustment of the temperature of the outlet air.

When the temperature control lever is in full cold position with the fan ON, the compressor will turn ON. A/C and REC indicator lamps (In VENT or B/L mode) will also light.

NFHA0072S03

RECIRCULATION (REC) SWITCH

OFF position: Outside air is drawn into the passenger compartment.

ON position: Interior air is recirculated inside the vehicle. The indicator lamp will also light.

Recirculation is canceled when DEF, D/F or FOOT is selected, and resumes when another mode is chosen. If the refrigerant pressure sensor input signal is high, recirculation is canceled, when VENT and B/L mode is selected.

NFHA0072S04

AIR CONDITIONER SWITCH

The air conditioner switch controls the A/C system. When the switch is depressed with the fan ON, the compressor will turn ON. The indicator lamp will also light.

The air conditioner cooling function operates only when the engine is running.

NFHA0072S05

REAR WINDOW DEFOGGER SWITCH

When illumination is ON, rear window is defogging.

NFHA0072S06

MAX. AIR CONDITIONER SWITCH

Intake door turns to recirculation position and the compressor operates automatically, when the temperature control level is in full cold position with the fan ON. The indicator lamps will also light.

NFHA0072S07

Discharge Air Flow

NFHA0073

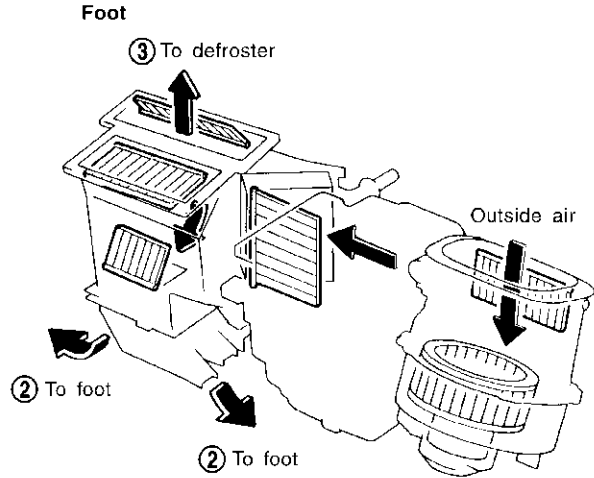
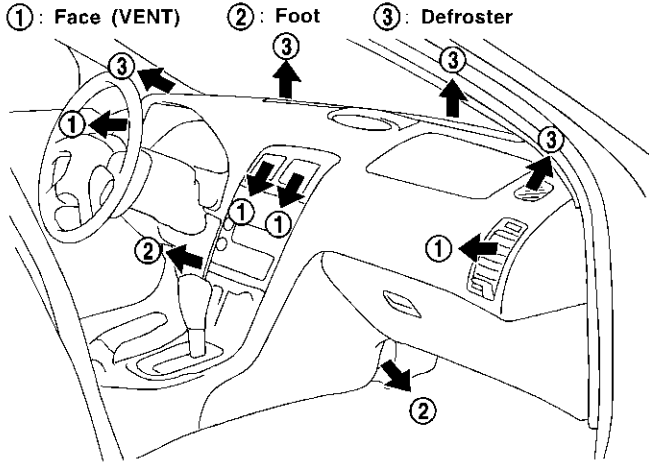

Face
 (🚗 switch "ON")

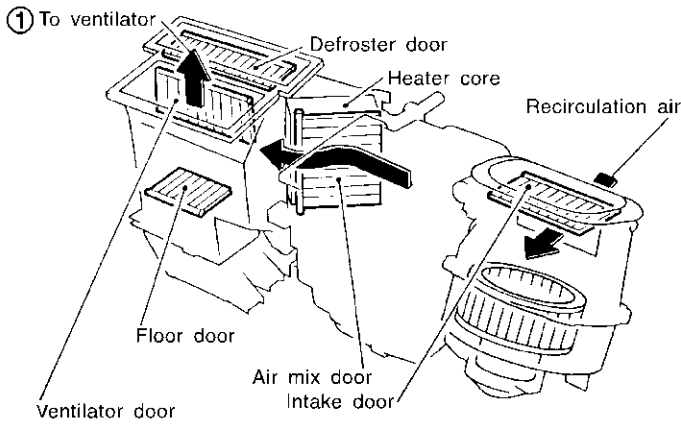

Foot and defroster

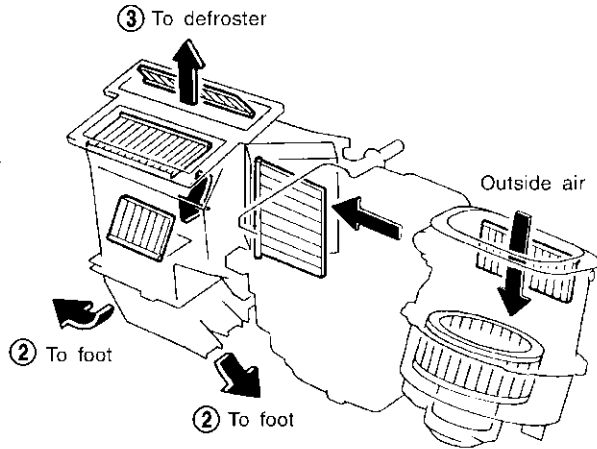

Bi-level
 (🚗 switch "OFF")

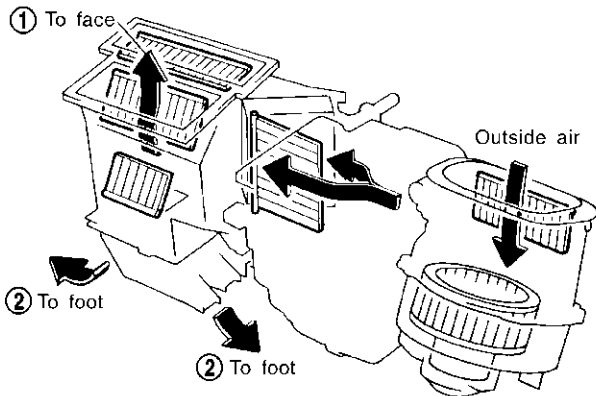

Defroster

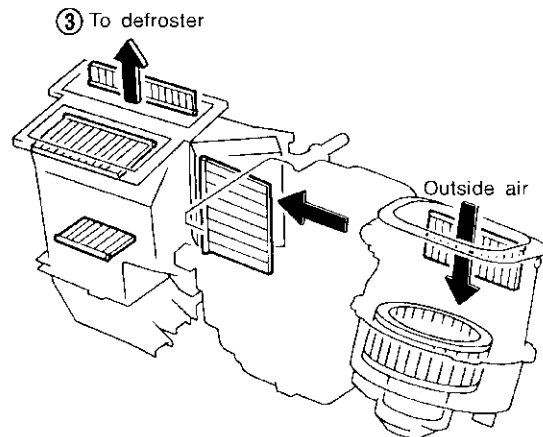

RHA355HB

**System Description
SWITCHES AND THEIR CONTROL FUNCTIONS**

NFHA0074

NFHA0074S01

Knob/Switch	Knob/Switch position							Air outlet	Intake air	Compressor
	A/C									
A/C	○							—	—	ON*1
Mode		○						VENT	—	—
			○					B/L	—	—
				○				FOOT	FRE	—
					○			D/F	FRE	—
						○		DEF	FRE	—
							○	—	REC*2	—

*1: Compressor is operated by ECM.

*2: In DEF, D/F and FOOT modes, REC switch is canceled.

MAX. A/C SWITCH CONTROL FUNCTION

NFHA0074S02

Lever/Switch	Condition: Fan ON				
MAX A/C (Full cold position)	OFF	⇒	ON	⇒	OFF
REC	OFF		ON*		OFF
A/C	OFF		ON		ON

*: When the temperature control lever is in the MAX. A/C position with the fan ON, the intake door automatically turns to the recirculation position.

GI
MA
EM
LC
EC
FE
CL
MT
AT
AX
SU
BR
ST
RS
BT
HA
SC
EL
IDX

Component Location

NFHA0085

NFHA0085S01

ENGINE COMPARTMENT

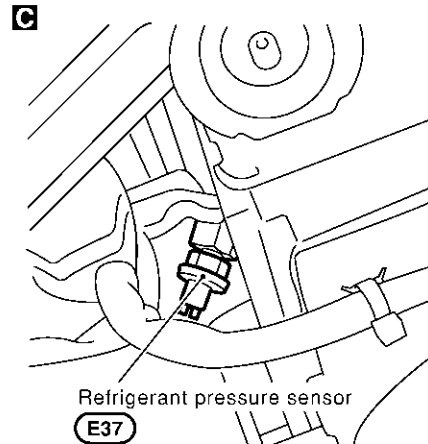
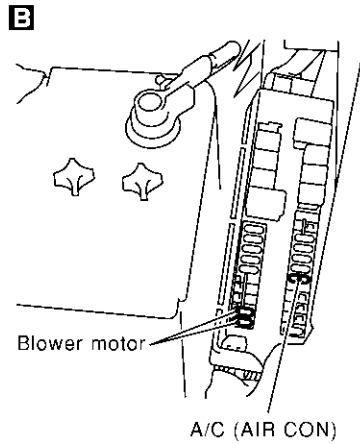
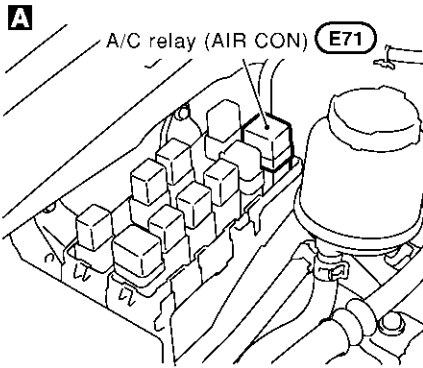

Relay box-1 **A**

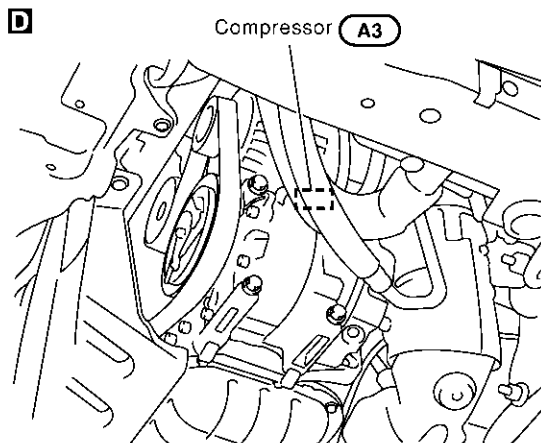
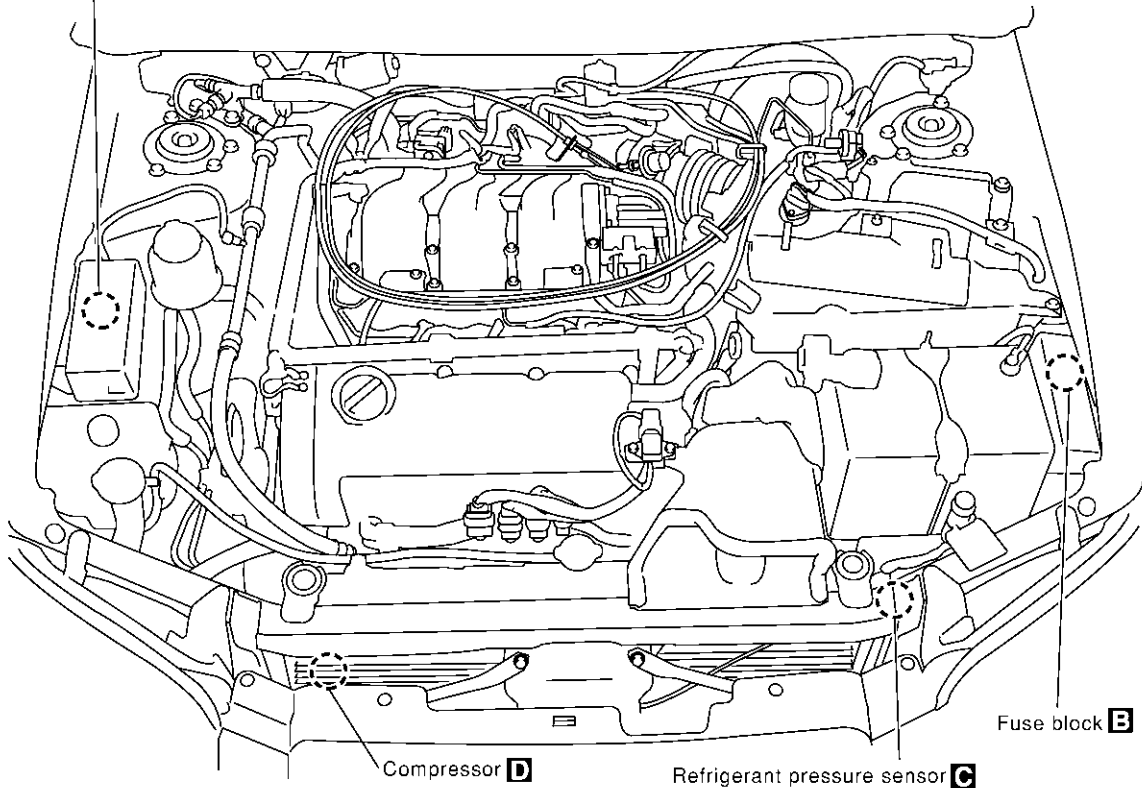

RHA0651

PASSENGER COMPARTMENT

NFHA0085S02

GI
MA
EM
LC
EC
FE
CL
MT
AT
AX
SU
BR
ST
RS
BT
HA
SC
EL
IDX

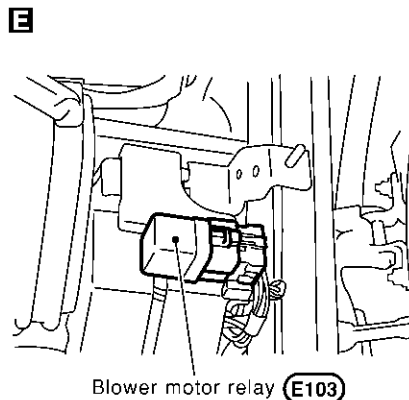
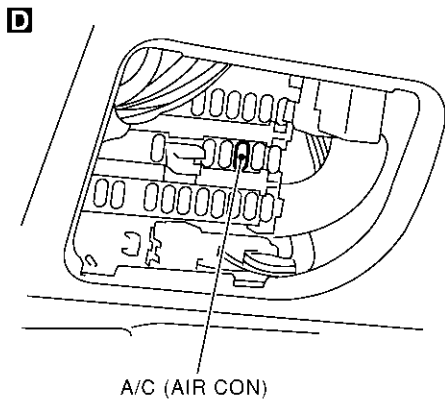
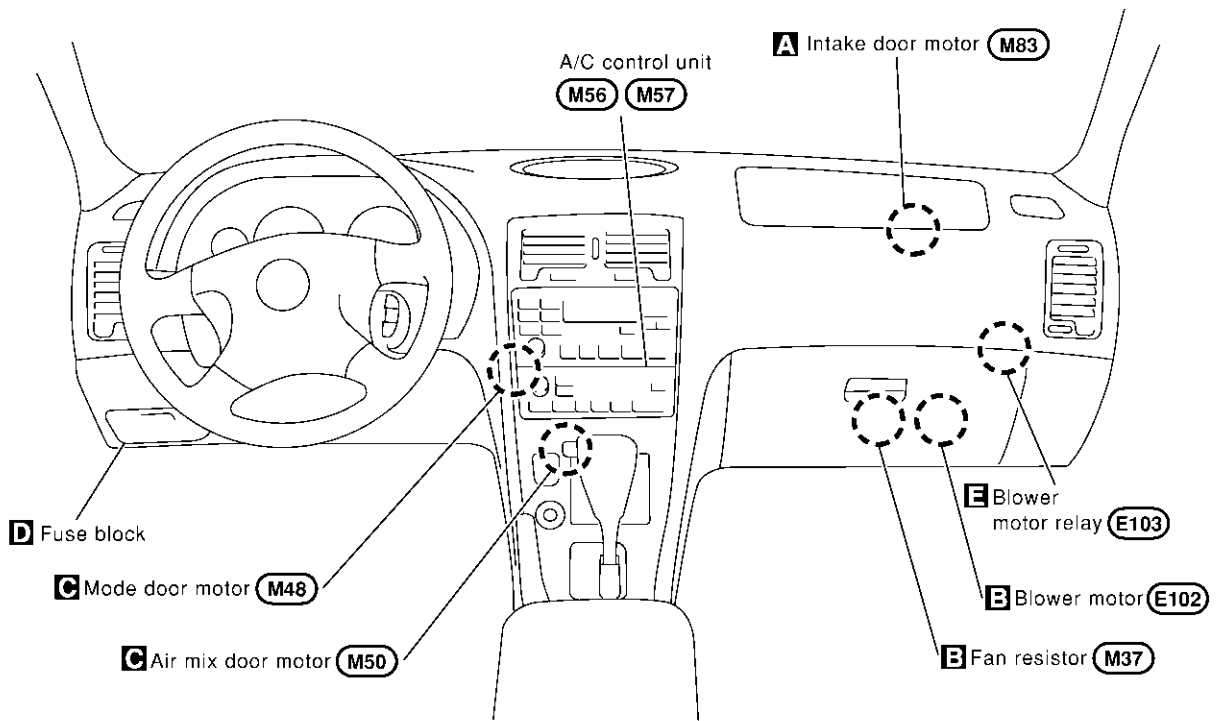
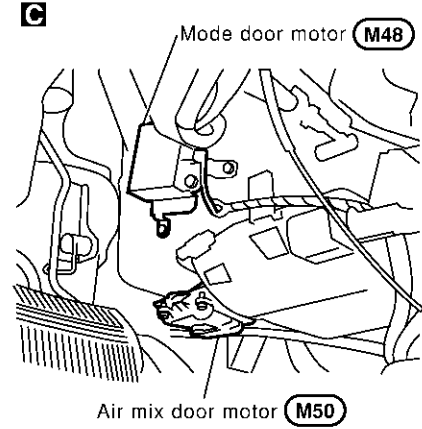
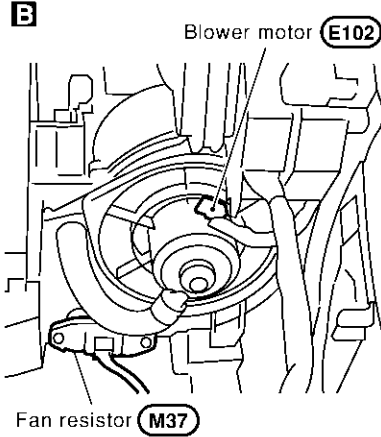
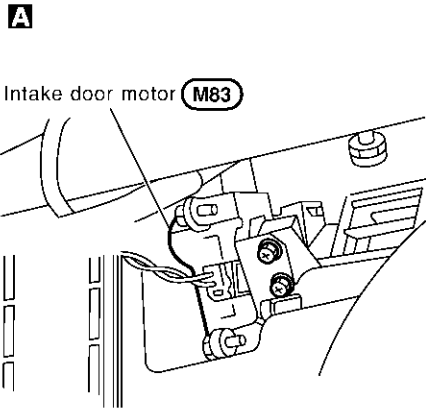

Circuit Diagram — Air Conditioner

NFHA0087

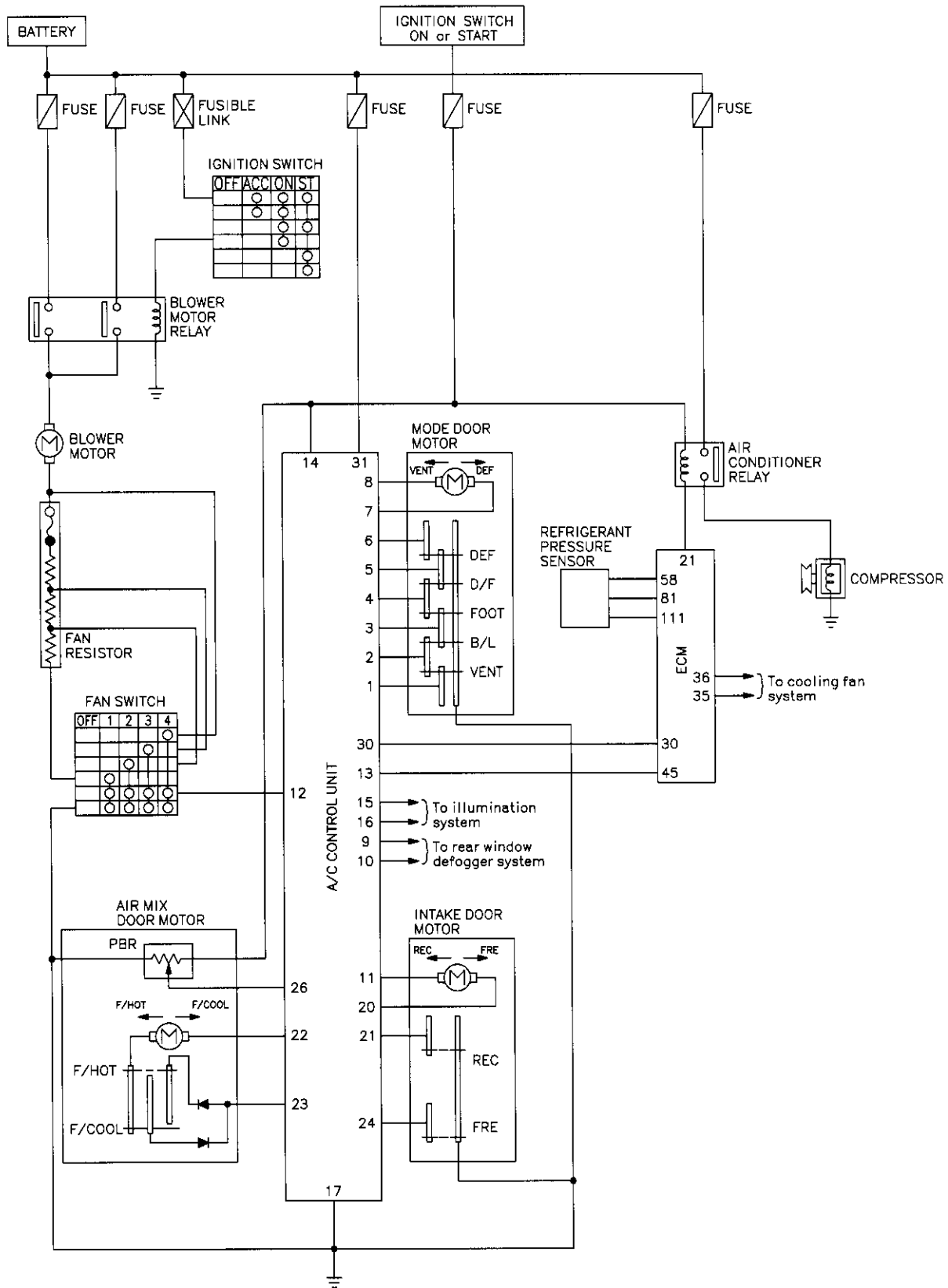

MHA054B

Wiring Diagram — A/C, M —

NFHA0088

HA-A/C,M-01

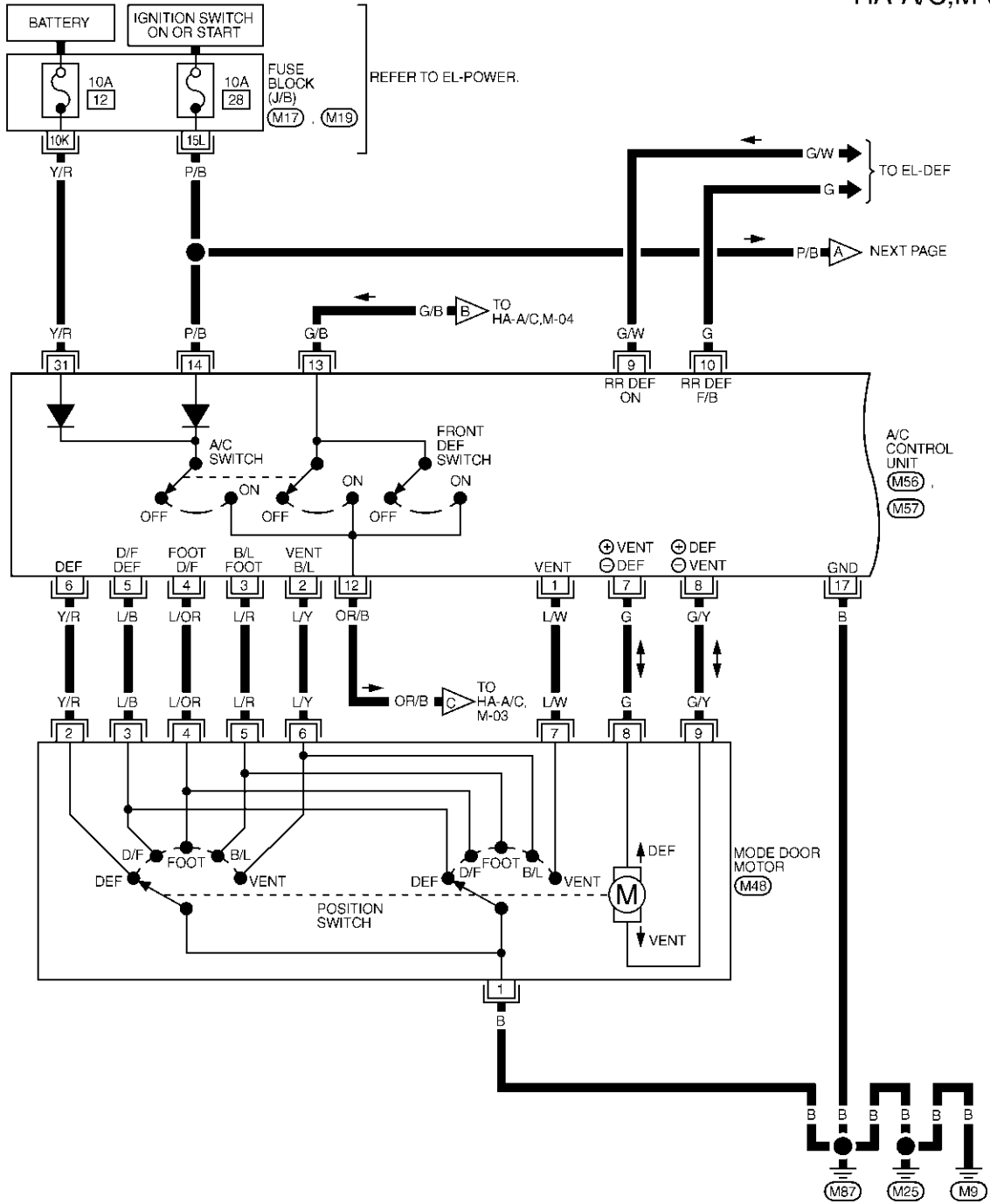

GI
MA
EM
LC
EC
FE
CL
MT
AT
AX
SU
BR
ST
RS
BT
HA

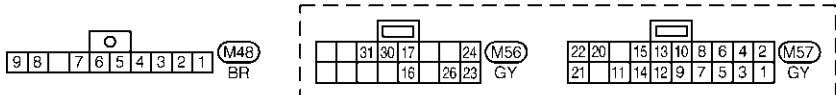

REFER TO THE FOLLOWING.
(M17) . (M19) - FUSE BLOCK - JUNCTION BOX (J/B)

HA-A/C,M-02

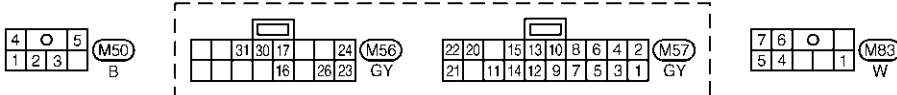
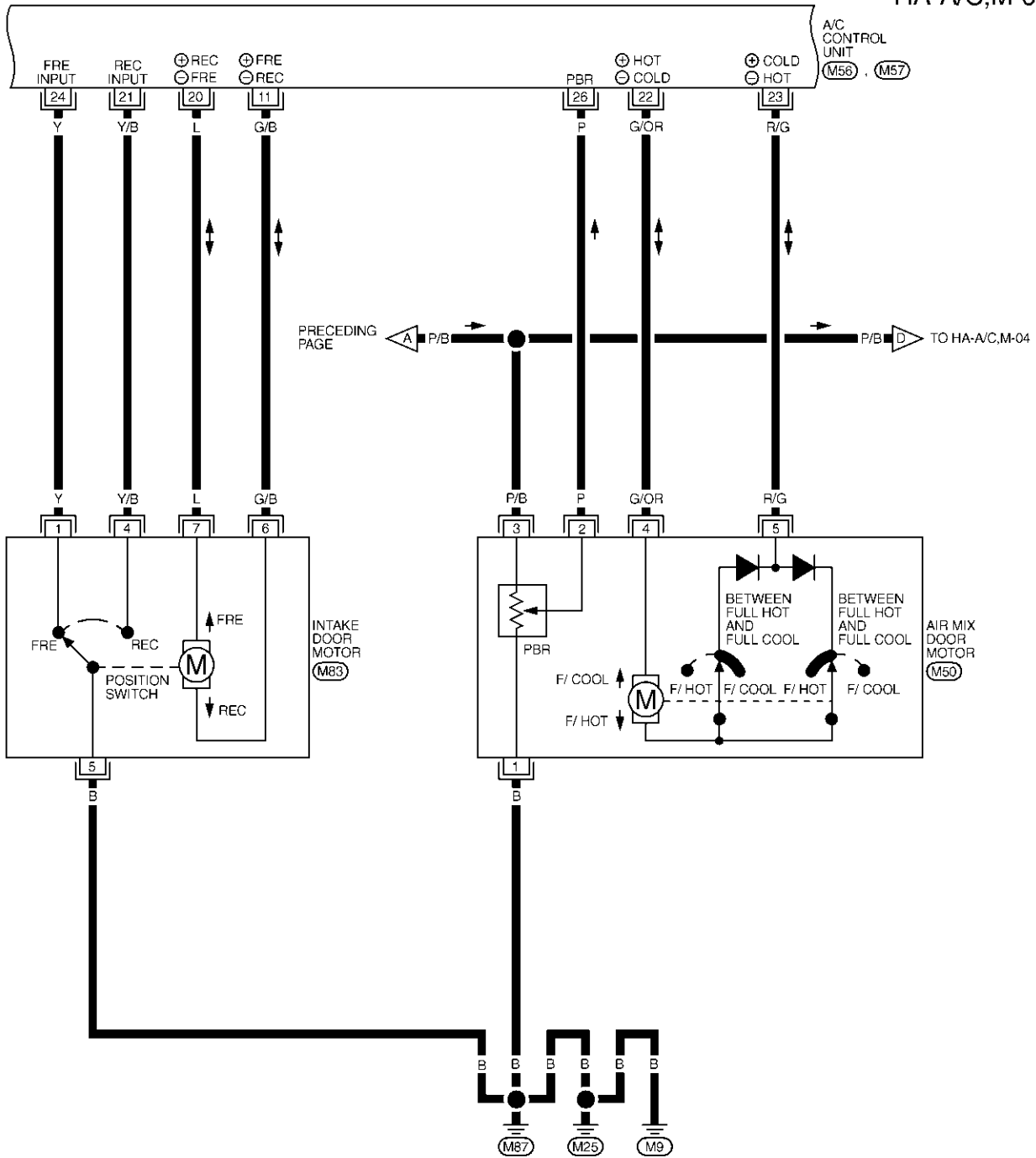

HA-A/C,M-03

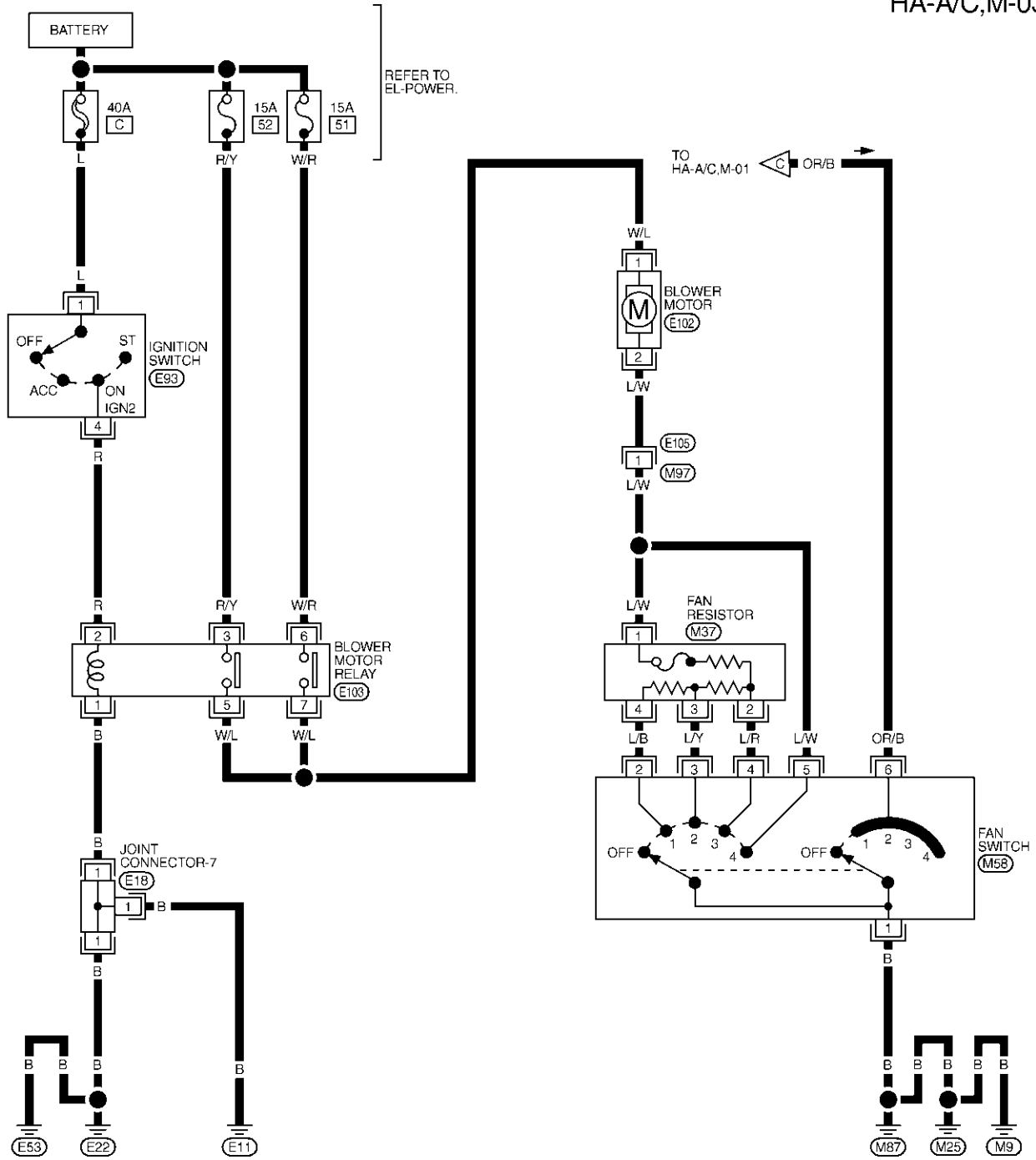

GI
MA
EM
LC
EC
FE
CL
MT
AT
AX
SU
BR
ST
RS
BT

HA

SC
EL
IDX

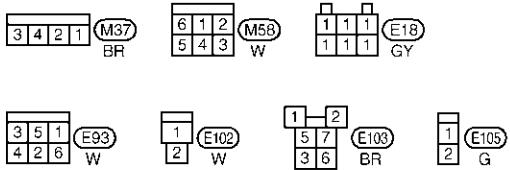

HA-A/C,M-04

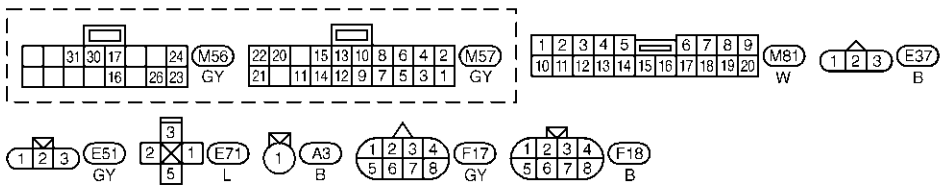
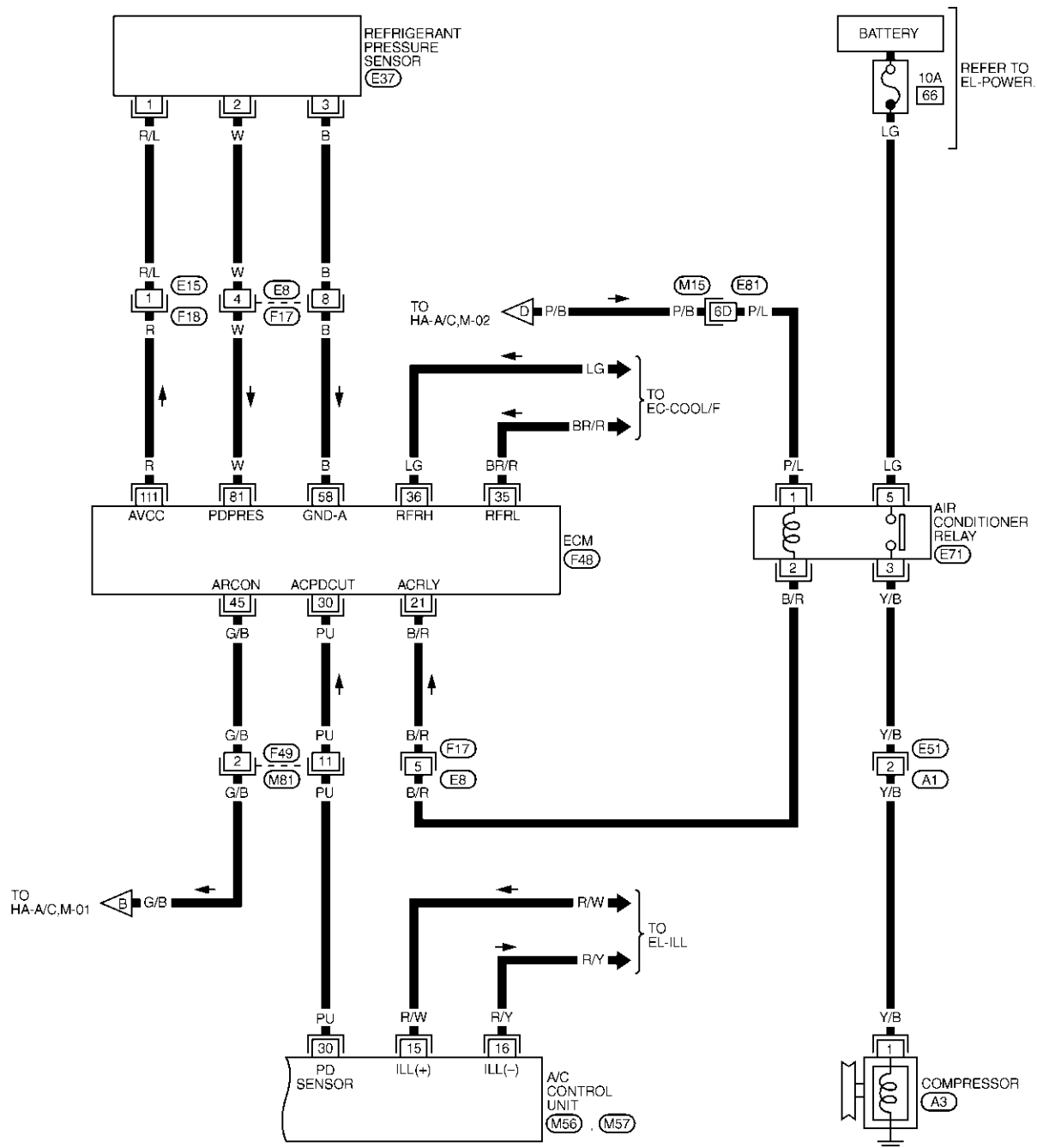

REFER TO THE FOLLOWING:
 (M15) - SUPER
 MULTIPLE JUNCTION (SMJ)
 (F48) - ELECTRICAL UNITS

How to Perform Trouble Diagnoses for Quick and Accurate Repair

NFHA0075

NFHA0075S01

WORK FLOW

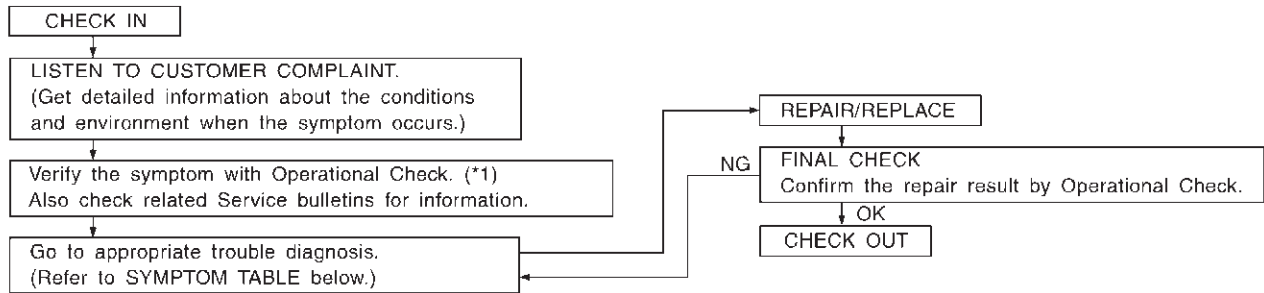

SHA900E

*1: HA-186

SYMPTOM TABLE

NFHA0075S02

Symptom	Reference page	
● A/C system does not come on.	● Go to Trouble Diagnosis Procedure for A/C system.	HA-188
● Intake door does not change in VENT, B/L or FOOT mode.	● Go to Trouble Diagnosis Procedure for Intake Door.	HA-191
● Blower motor does not rotate at all.	● Go to Trouble Diagnosis Procedure for Blower Motor.	HA-195
● Air mix door motor does not operate normally.	● Go to Trouble Diagnosis Procedure for Air mix door motor.	HA-201
● Mode door does not change.	● Go to Trouble Diagnosis Procedure for Mode door.	HA-205
● Magnet clutch does not engage when A/C switch and fan switch are ON.	● Go to Trouble Diagnosis Procedure for Magnet Clutch.	HA-208
● Insufficient cooling.	● Go to Trouble Diagnosis Procedure for Insufficient cooling.	HA-215
● Insufficient heating.	● Go to Trouble Diagnosis Procedure for Insufficient heating.	HA-223
● Noise	● Go to Trouble Diagnosis Procedure for Noise.	HA-224

GI
MA
EM
LC
EC
FE
CL
MT
AT
AX
SU
BR
ST
RS
BT
HA
SC
EL
IDX

Operational Check

=NFHA0076

The purpose of the operational check is to confirm that the system operates as it should. The systems which are checked are the blower, mode (discharge air), intake air, temperature decrease, temperature increase.

CONDITIONS:

Engine running at normal operating temperature.

NFHA0076S01

PROCEDURE:

NFHA0076S02

1. Check Blower

NFHA0076S0201

1. Turn fan control dial to 1-speed.
Blower should operate on 1-speed.
2. Then turn fan control dial to 2-speed.
3. Continue checking blower speed until all four speeds are checked.
4. Leave blower on 4-speed.

If NG, go to trouble diagnosis procedure for blower motor (HA-195).
If OK, continue with next check.

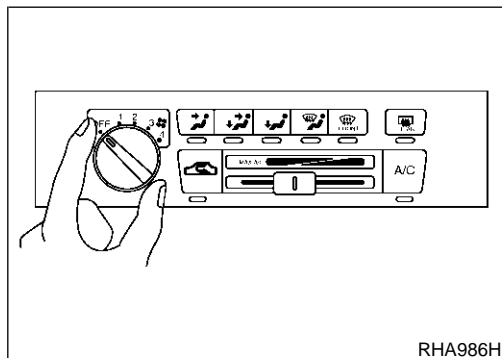

2. Check Discharge Air

NFHA0076S0202

1. Press each mode switch.

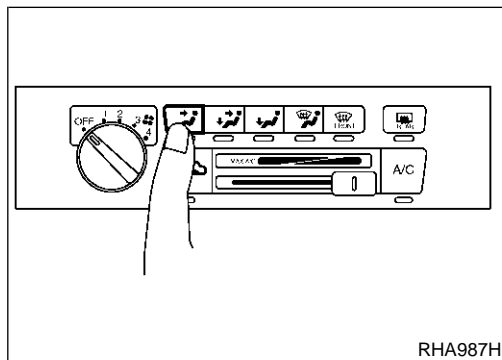

2. Confirm that discharge air comes out according to the air distribution table at left.

Refer to "Discharge Air Flow" in "DESCRIPTION" (HA-176).

NOTE:

Confirm that the compressor clutch is engaged (visual inspection) and intake door position is at FRESH when the DEF (DEF) is pressed.

Confirm that the intake door position is at FRESH when the D/F (D/F) is pressed.

Intake door position is checked in the next step.

If NG, go to trouble diagnosis procedure for mode door motor (HA-205).

If OK, continue with next check.

Discharge air flow

Mode switch	Air outlet/distribution		
	Face	Foot	Defroster
	100%	-	-
	60%	40%	-
	-	80%	20%
	-	60%	40%
	-	-	100%

SHA345F

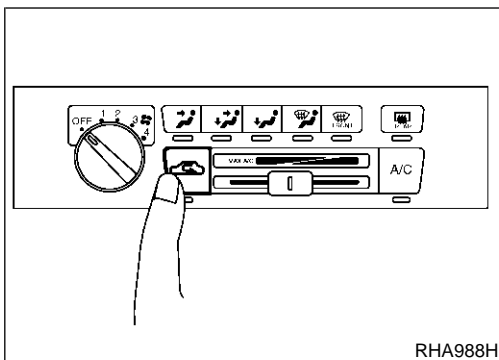

3. Check Recirculation

NFHA0076S0203

1. Press recirculation switch.
Recirculation indicator should light.
2. Listen for intake door position change (you should hear blower sound change slightly).

NOTE:

Confirm that the RECIRCULATION (REC) switch is canceled in the DEF (☼) and D/F (☼) mode.

If NG, go to trouble diagnosis procedure for intake door motor (HA-191).

If OK, continue with next check.

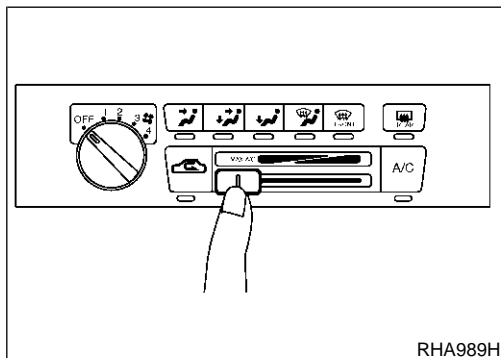

4. Check Temperature Decrease

NFHA0076S0204

1. Turn fan control dial to 1-speed.
2. Slide temperature control lever to full cold.
3. Check for cold air at discharge air outlets.

If NG, go to trouble diagnosis procedure for insufficient cooling (HA-215).

If OK, continue with next check.

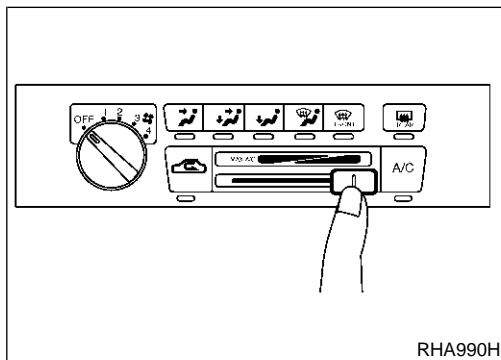

5. Check Temperature Increase

NFHA0076S0205

1. Slide temperature control lever to full hot.
2. Check for hot air at discharge air outlets.

If NG, go to trouble diagnosis procedure for insufficient heating (HA-223).

If OK, continue with next check.

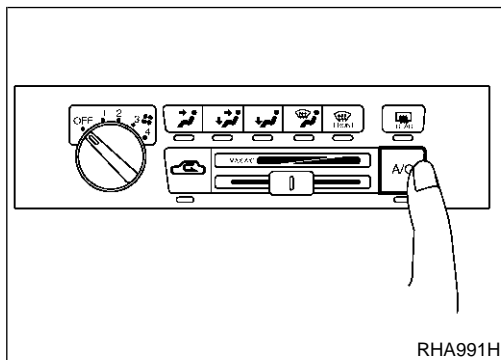

6. Check Air Conditioner Switch

NFHA0076S0206

Turn fan control switch to the desired (1 to 4-speed) position and push the air conditioner switch to turn ON the air conditioner. The indicator light should come on when air conditioner is ON.

If NG, go to trouble diagnosis procedure for A/C system (HA-188).

If OK, continue with next check.

If all operational check are OK (symptom can not be duplicated), go to "Incident Simulation Tests" (GI-25) and perform tests as outlined to simulate driving conditions environment. If symptom appears, refer to "Symptom Table" (HA-185) and perform applicable trouble diagnosis procedures.

GI

MA

EM

LC

EC

FE

CL

MT

AT

AX

SU

BR

ST

RS

BT

HA

SC

EL

IDX

A/C System

TROUBLE DIAGNOSIS PROCEDURE FOR A/C SYSTEM

=NFHA0253

Symptom:

- A/C system does not come on.

INSPECTION FLOW

1. Confirm symptom by performing the following operational check.

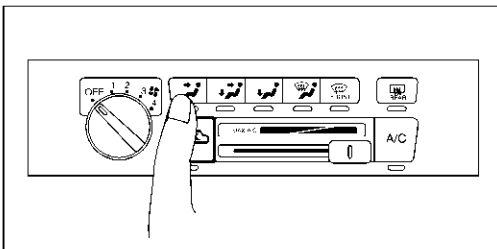

OPERATIONAL CHECK

Confirm that the system operate normally.

If OK (symptom cannot be duplicated), perform complete operational check (*2).
If NG (symptom is confirmed), continue with STEP-2 following.

2. Check for any service bulletins.

OK

3. Check main power supply and ground circuit. (*1)

OK

4. Go to A/C system circuit. (*3)

OK

5. Replace push control unit.

OK

INSPECTION END

*1: HA-189

*2: HA-186

*3: HA-180

MAIN POWER SUPPLY AND GROUND CIRCUIT CHECK

=NFHA0254

Power Supply Circuit Check

NFHA0254S01

Check power supply circuit for air conditioner system.
Refer to EL-12, "Wiring Diagram — POWER —".

GI

MA

EM

LC

DIAGNOSTIC PROCEDURE

NFHA0255

SYMPTOM:

- A/C system does not come on.

EC

1	CHECK POWER SUPPLY CIRCUIT FOR A/C CONTROL UNIT									
<p>Measure voltage between harness connector terminal Nos. 14, 31 and ground.</p>										
RHA993HB										
<table border="1" style="margin: auto; border-collapse: collapse;"> <thead> <tr> <th colspan="2">Votmeter terminal</th> <th rowspan="2">Voltage</th> </tr> <tr> <th>(+)</th> <th>(-)</th> </tr> </thead> <tbody> <tr> <td>14</td> <td rowspan="2">Ground</td> <td rowspan="2">Approx. 12V</td> </tr> <tr> <td>31</td> </tr> </tbody> </table>		Votmeter terminal		Voltage	(+)	(-)	14	Ground	Approx. 12V	31
Votmeter terminal		Voltage								
(+)	(-)									
14	Ground	Approx. 12V								
31										
MTBL1600										
OK or NG										
OK	▶ GO TO 2.									
NG	▶ Check 10A fuses [Nos. 12, 28 located in the fuse block (J/B)].									

FE

CL

MT

AT

AX

SU

BR

ST

RS

BT

HA

SC

EL

IDX

A/C System (Cont'd)

2	CHECK BODY GROUND CIRCUIT FOR A/C CONTROL UNIT									
<p>Check for continuity between harness connector terminal No. 17 and ground.</p> <div style="text-align: center;"> <p>A/C control unit connector (M56)</p> </div>										
		RHA391H								
<table border="1" style="margin: auto; border-collapse: collapse;"> <thead> <tr> <th colspan="2">Ohmmeter terminal</th> <th rowspan="2">Continuity</th> </tr> <tr> <th>(+)</th> <th>(-)</th> </tr> </thead> <tbody> <tr> <td style="text-align: center;">17</td> <td style="text-align: center;">Ground</td> <td style="text-align: center;">Yes</td> </tr> </tbody> </table>		Ohmmeter terminal		Continuity	(+)	(-)	17	Ground	Yes	MTBL1601
Ohmmeter terminal		Continuity								
(+)	(-)									
17	Ground	Yes								
OK or NG										
OK	▶	INSPECTION END								
NG	▶	If NG, repair harness or connector.								

Intake Door

TROUBLE DIAGNOSIS PROCEDURE FOR INTAKE DOOR

=NFHA0135

Symptom:

- Intake door does not change in VENT, B/L or FOOT mode.

Inspection Flow

GI
 MA
 EM
 LC
 EC
 FE
 CL
 MT
 AT
 AX
 SU
 BR
 ST
 RS
 BT
 HA
 SC
 EL
 IDX

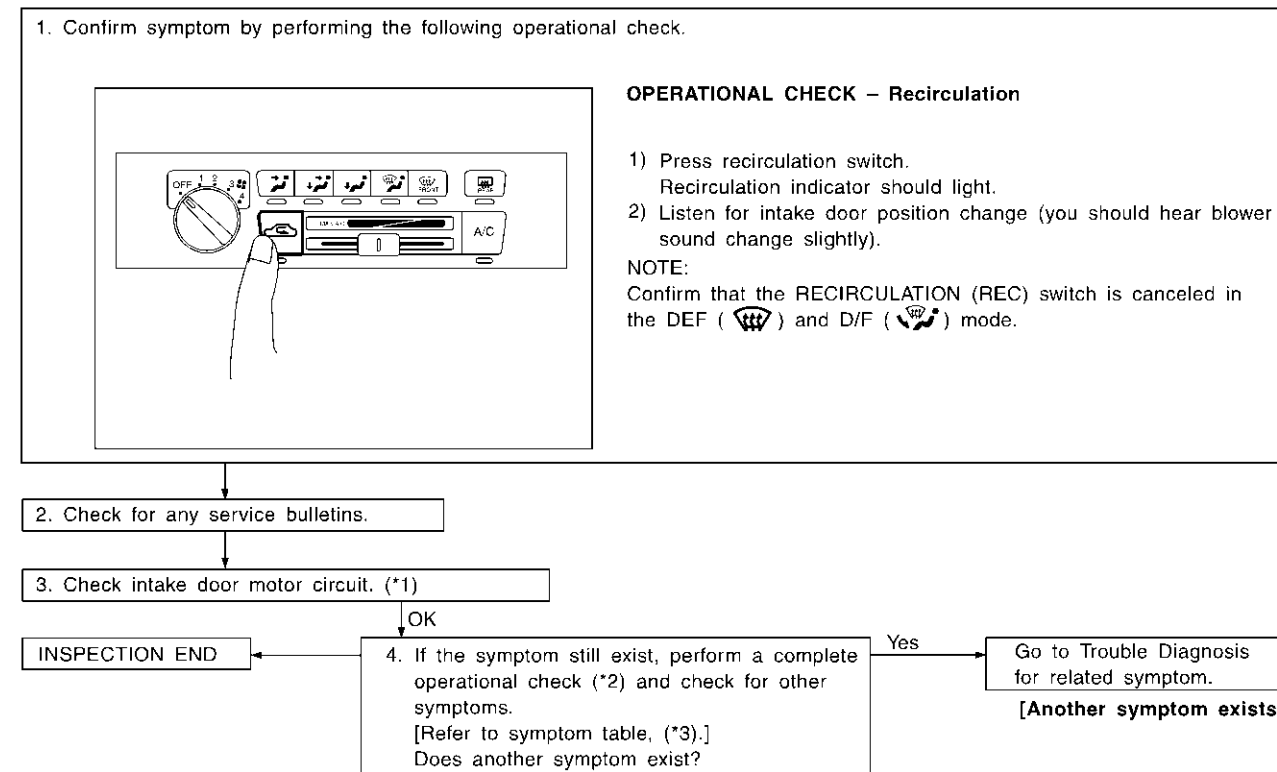

RHA994HA

*1: HA-192

*2: HA-186

*3: HA-185

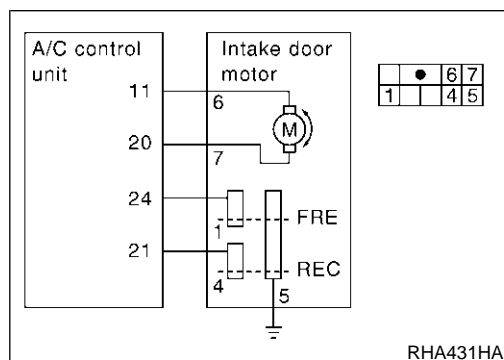

SYSTEM DESCRIPTION

Intake Door Motor

NFHA0136

NFHA0136S01

The intake door motor is installed on the blower and intake unit. Using a link it opens and closes the intake door. When RECIRCULATION switch is at REC (except DEF and D/F modes), the A/C control unit sets the intake door at the "RECIRCULATION" position. RECIRCULATION switch is canceled by MODE switch in DEF and D/F modes.

Intake Door (Cont'd)

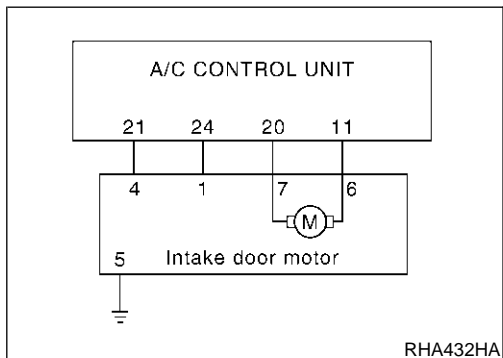
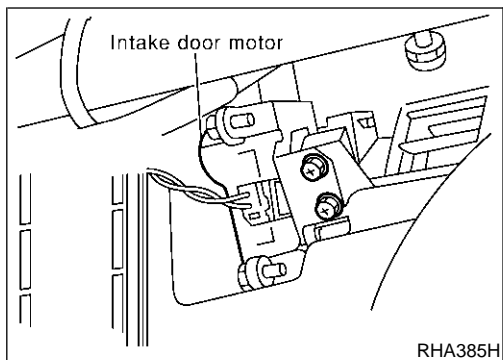

DIAGNOSTIC PROCEDURE

SYMPTOM: Intake door motor does not operate normally.

NFHA0090

1	CHECK BODY GROUND CIRCUIT FOR INTAKE DOOR MOTOR
<p>Check circuit continuity between intake door harness connector terminal No. 5 and ground.</p> <div style="text-align: center;"> </div> <p style="text-align: right;">RHA433H</p>	
<p>Continuity should exist. If OK, check harness for short.</p> <p style="text-align: center;">OK or NG</p>	
OK	▶ GO TO 2.
NG	▶ Repair harness or connector.

2
CHECK FOR AUTO AMP. OUTPUT

Measure voltage across auto amp. harness connector terminals and ground.

A/C control unit connector (M57)

Terminals: 11, 20

Wires: G/B, L

Voltmeter (V)

Switch: ON

Recirculation switch condition	Terminals No.		Condition	Voltage V
	(+)	(-)		
REC	20	Ground	REC	12
	11			0
FRE	11	Ground	FRE	12
	20			0

0V : Approx. 0V
12V: Approx. 12V

SHA324FD

OK or NG

OK	▶	INSPECTION END
NG	▶	GO TO 3.

GI
MA
EM
LC
EC
FE
CL
MT
AT
AX
SU
BR
ST
RS
BT
HA
SC
EL
IDX

3
CHECK CIRCUIT CONTINUITY BETWEEN EACH TERMINAL ON A/C CONTROL UNIT AND ON INTAKE DOOR MOTOR

Intake door motor connector (M83)

A/C control unit connector (M57)

A/C control unit connector (M56)

Intake door motor connector (M83) terminals: 1, 4, 6, 7

A/C control unit connector (M57) terminals: 11, 20, 21

A/C control unit connector (M56) terminal: 24

Wires: Y, G/B, L, Y/B

Continuity Tester (Ω)

Switch: OFF

Terminal No.		Continuity
A/C control unit	Intake door motor	
11	6	Yes
20	7	
21	4	
24	1	

Continuity should exist.
If OK, check harness for short.

RHA435HC

OK or NG

OK	▶	GO TO 4.
NG	▶	Repair harness or connector.

Intake Door (Cont'd)

4 CHECK FOR A/C CONTROL UNIT OUTPUT

Measure voltage across A/C control unit harness connector terminals and ground.

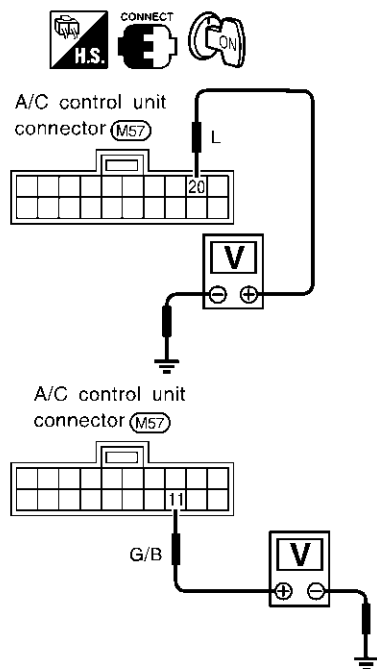

RECIRCULATION SWITCH	Terminals No.		Condition	Voltage V
	(+)	(-)		
REC (ON)	20	Ground	REC	12
	11			0
FRE (OFF)	20		FRE	0
	11			12

0V: Approx. 0V
12V: Approx. 12V

RHA436HB

OK or NG

- | | | |
|----|---|----------------------------|
| OK | ▶ | Replace intake door motor. |
| NG | ▶ | Replace A/C control unit. |

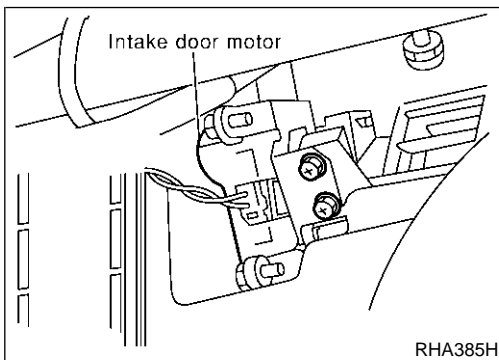

RHA385H

CONTROL LINKAGE ADJUSTMENT

Intake Door Motor

NFHA0093

NFHA0093S04

1. Install intake door motor on blower and intake unit. Ensure that the intake door motor lever is fitted into the slit portion of intake door link.
2. Connect the intake door motor harness connector.
3. Turn ignition switch to ON.
4. Check that intake door operates properly when RECIRCULATION switch is turned ON and OFF.

Blower Motor

TROUBLE DIAGNOSIS PROCEDURE FOR BLOWER MOTOR

=NFHA0138

Symptom:

- Blower motor does not rotate at all.

Inspection Flow

GI
MA
EM
LC
EC
FE
CL
MT
AT
AX
SU
BR
ST
RS
BT
HA
SC
EL
IDX

1. Confirm symptom by performing the following operational check.

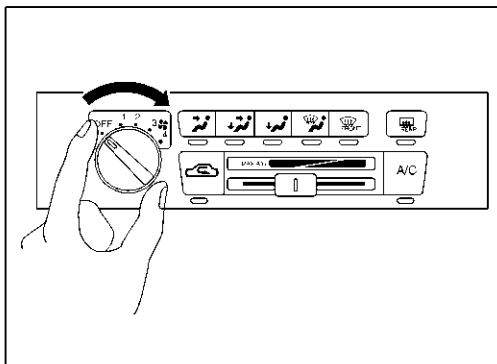

OPERATIONAL CHECK – Blower motor

- 1) Turn fan control dial to 1-speed.
Blower should operate on 1-speed.
- 2) Then turn fan control dial to 2-speed.
- 3) Continue checking blower speed until all four speeds are checked.
- 4) Leave blower on 4-speed.

**If OK (symptom cannot be duplicated), perform complete operational check (*2).
If NG (symptom is confirmed), continue with STEP-2 following.**

2. Check for any service bulletins.

3. Check blower motor circuit. (*1)

OK

INSPECTION END

4. If the symptom still exist, perform a complete operational check (*2) and check for other symptoms.
[Refer to symptom table, (*3).]
Does another symptom exist?

Yes

Go to Trouble Diagnosis for related symptom.
[Another symptom exists.]

SHA781F

*1: HA-197

*2: HA-186

*3: HA-185

Blower Motor (Cont'd)

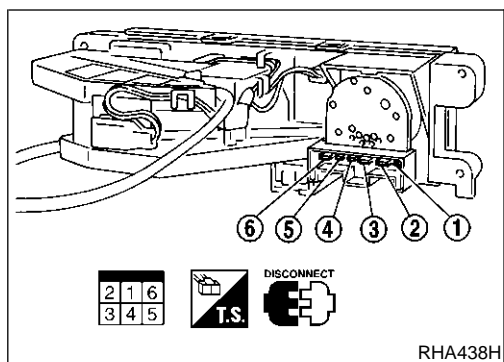

RHA438H

ELECTRICAL COMPONENTS INSPECTION

=NFHA0139

Fan Switch

NFHA0139S01

Check continuity between terminals at each switch position.

SWITCH POSITION	Continuity between terminals
OFF	
1	2 — 1 — 6
2	3 — 1 — 6
3	4 — 1 — 6
4	5 — 1 — 6

Blower Motor

NFHA0139S02

Confirm smooth rotation of the blower motor.

- Ensure that there are no foreign particles inside the intake unit.

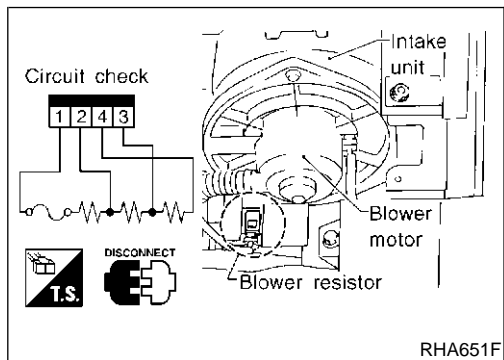

RHA651F

Blower Resistor

NFHA0139S03

Check resistance between terminals.

Terminal No.		Resistance
(+)	(-)	
3	1	Approx. 0.9 - 1.1Ω
4		Approx. 2.75 - 2.95Ω
2		Approx. 0.3 - 0.5Ω

DIAGNOSTIC PROCEDURE

=NFHA0089

SYMPTOM:

- **Blower motor does not rotate.**

Test group No.	INCIDENT
1	Fan fails to rotate.
2	Fan does not rotate at 1-speed.
3	Fan does not rotate at 2-speed.
4	Fan does not rotate at 3-speed.
5	Fan does not rotate at 4-speed.

1	DIAGNOSTIC PROCEDURE	
Check if blower motor rotates properly at each fan speed. Conduct checks as per table at above.		
1	▶	GO TO 2.
2, 3, 4	▶	GO TO 8.
5	▶	GO TO 10.

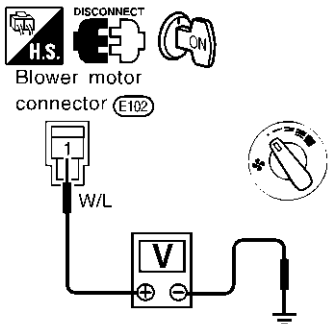
2	CHECK POWER SUPPLY FOR BLOWER MOTOR	
<p>1. Disconnect blower motor harness connector. 2. Do approx. 12 volts exist between blower motor harness connector terminal No. 1 and ground?</p> <div style="text-align: center;">  <p style="text-align: center;">Blower motor connector (E102)</p> <p style="text-align: center;">Yes or No</p> </div> <p style="text-align: right;">RHA343FC</p>		
Yes	▶	GO TO 3.
No	▶	Check 15A fuses [Nos. 51 and No. 52, located in the fuse block (J/B)]. Refer to EL-12, "Wiring Diagram — POWER —". Check blower relay.

Blower Motor (Cont'd)

3	CHECK CIRCUIT CONTINUITY FOR BLOWER MOTOR	
<p>1. Turn fan control switch to any position except OFF. 2. Check circuit continuity between blower motor harness connector terminal No. 2 and ground.</p> <div style="text-align: center;"> <p style="text-align: center;">Blower motor connector (E102)</p> </div> <p style="color: blue; font-weight: bold;">Continuity should exist.</p> <p style="text-align: center;">OK or NG</p>		
OK	▶	GO TO 4.
NG	▶	Reconnect blower motor harness connector. GO TO 5.

RHA344FC

4	CHECK BLOWER MOTOR	
<p>(Refer to Electrical Components Inspection.) (HA-196)</p> <p style="text-align: center;">OK or NG</p>		
OK	▶	INSPECTION END
NG	▶	Replace blower motor.

5	CHECK BLOWER MOTOR CIRCUIT BETWEEN BLOWER MOTOR AND RESISTOR	
<p>Do approx. 12 volts exist between resistor harness connector terminal No. 1 and ground?</p> <div style="text-align: center;"> <p style="text-align: center;">Resistor connector (M37)</p> </div> <p style="text-align: center;">Yes or No</p>		
Yes	▶	Disconnect fan switch harness connector. GO TO 7.
No	▶	Disconnect blower motor and resistor harness connectors. GO TO 6.

RHA575FB

6	CHECK CIRCUIT CONTINUITY BETWEEN BLOWER MOTOR AND RESISTOR	
Check circuit continuity between blower motor harness connector terminal No. 2 and resistor harness connector terminal No. 1.		
RHA576FB		
<p>Continuity should exist. If OK, check harness for short.</p> <p style="text-align: center;">OK or NG</p>		
OK	▶	INSPECTION END
NG	▶	Repair harness or connector.

GI
MA
EM
LC
EC
FE
CL

7	CHECK GROUND CIRCUIT FOR FAN SWITCH	
Check circuit continuity between fan switch harness connector terminal No. 1 and ground.		
RHA440H		
OK or NG		
OK	▶	GO TO 8.
NG	▶	Repair harness or connector.

MT
AT
AX
SU
BR
ST
RS

8	CHECK RESISTOR AFTER DISCONNECTING IT	
(Refer to Electrical Components Inspection.) (HA-196)		
OK or NG		
OK	▶	GO TO 9.
NG	▶	Replace resistor.

BT
HA
SC

9	CHECK RESISTOR HARNESS CONNECTOR	
Reconnect resistor harness connector.		
OK or NG		
1	▶	GO TO 12.
2, 3, 4	▶	GO TO 10.

EL
IDX

Blower Motor (Cont'd)

10	CHECK FAN SWITCH CIRCUIT																		
Do approx. 12 volts exist between each fan switch harness connector terminal and ground?																			
		<table border="1" style="width: 100%; border-collapse: collapse; text-align: center;"> <thead> <tr> <th rowspan="2">Test group No.</th> <th colspan="2">Terminals No.</th> <th rowspan="2">Voltage</th> </tr> <tr> <th>(+)</th> <th>(-)</th> </tr> </thead> <tbody> <tr> <td>2</td> <td>5</td> <td rowspan="4">Ground</td> <td rowspan="4">Approx. 12V</td> </tr> <tr> <td>3</td> <td>4</td> </tr> <tr> <td>4</td> <td>3</td> </tr> <tr> <td>5</td> <td>2</td> </tr> </tbody> </table>		Test group No.	Terminals No.		Voltage	(+)	(-)	2	5	Ground	Approx. 12V	3	4	4	3	5	2
Test group No.	Terminals No.		Voltage																
	(+)	(-)																	
2	5	Ground	Approx. 12V																
3	4																		
4	3																		
5	2																		
SHA325FA																			
Yes or No																			
Yes		▶ GO TO 12.																	
No		▶ GO TO 11.																	

11	CHECK CIRCUIT CONTINUITY BETWEEN FAN SWITCH HARNESS CONNECTOR TERMINAL AND RESISTOR HARNESS CONNECTOR TERMINAL																	
		<table border="1" style="width: 100%; border-collapse: collapse; text-align: center;"> <thead> <tr> <th rowspan="2">Fan switch</th> <th colspan="2">Terminal No.</th> <th rowspan="2">Continuity</th> </tr> <tr> <th>Fan switch</th> <th>Resistor</th> </tr> </thead> <tbody> <tr> <td>2</td> <td>4</td> <td rowspan="4">Yes</td> </tr> <tr> <td>3</td> <td>3</td> </tr> <tr> <td>4</td> <td>2</td> </tr> <tr> <td>5</td> <td>1</td> </tr> </tbody> </table>		Fan switch	Terminal No.		Continuity	Fan switch	Resistor	2	4	Yes	3	3	4	2	5	1
Fan switch	Terminal No.		Continuity															
	Fan switch	Resistor																
2	4	Yes																
3	3																	
4	2																	
5	1																	
SHA326F																		
OK or NG																		
OK		▶ Check harness for short.																
NG		▶ Repair harness or connector.																

12	CHECK FAN SWITCH AFTER DISCONNECTING IT		
(Refer to Electrical Components Inspection.) (HA-196)			
OK or NG			
OK		▶ INSPECTION END	
NG		▶ Replace fan switch.	

Air Mix Door

TROUBLE DIAGNOSIS PROCEDURE FOR AIR MIX DOOR MOTOR

=NFHA0256

SYMPTOM:

- Air mix door motor does not operate normally.

INSPECTION FLOW

GI

MA

EM

LC

EC

FE

CL

MT

AT

AX

SU

BR

ST

RS

BT

HA

SC

SHA783F

EL

IDX

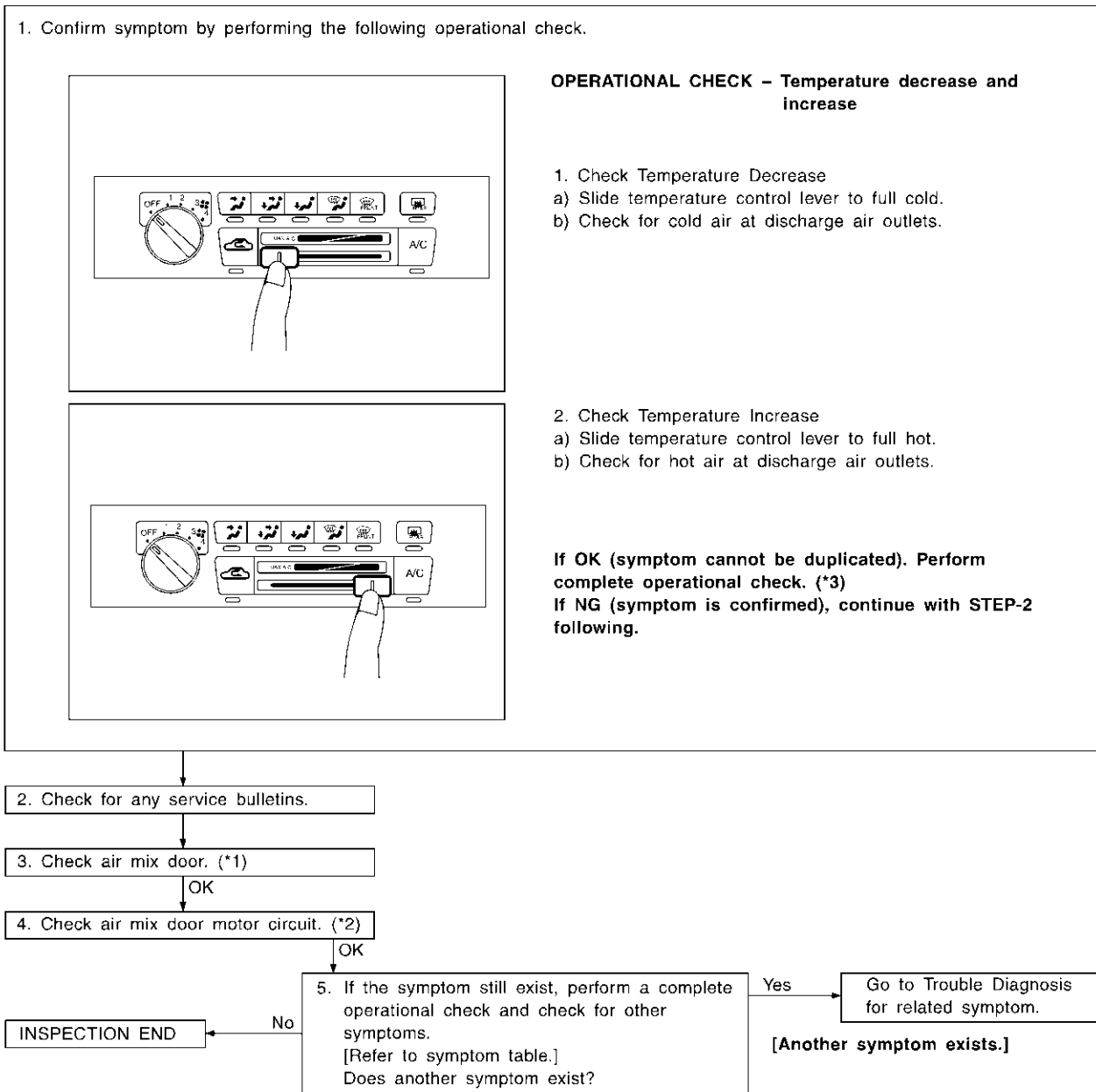

*1: HA-204

*2: HA-203

*3: HA-186

Air Mix Door (Cont'd)

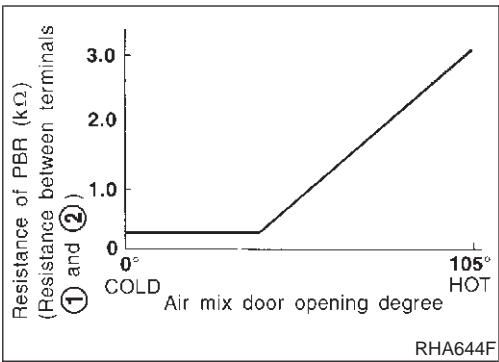

CONTROL SYSTEM INPUT COMPONENT

PBR

NFHA0258

NFHA0258S01

Measure resistance corresponding to the air mix door opening degree between terminals 1 and 2 at vehicle harness side.

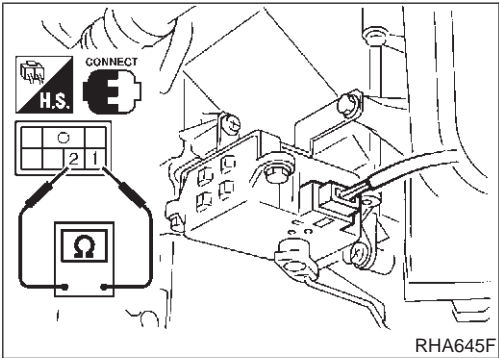

DIAGNOSTIC PROCEDURE

SYMPTOM:

- Air mix door motor does not operate normally.

1	CHECK POWER SUPPLY FOR A/C CONTROL UNIT.	
Refer to "MAIN POWER SUPPLY AND GROUND CIRCUIT CHECK", HA-189.		
OK or NG		
OK	▶	GO TO 2.
NG	▶	Check A/C control unit power circuit. <ul style="list-style-type: none"> ● Check 10A fuses [Nos. 12 and 28, located in the fuse block (J/B)] ● If fuses are OK, check for open circuit in wiring harness. Repair or replace as necessary. ● If fuses are NG, replace and check wiring harness for short circuit. Repair or replace as necessary.

2	CHECK PBR	
Refer to HA-202.		
OK or NG		
OK	▶	GO TO 3.
NG	▶	Replace air mix door motor.

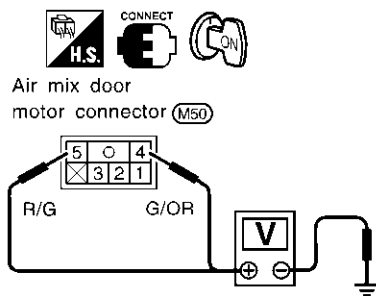
3	CHECK FOR OUTPUT OF AUTO AMP.													
Do approx. 10.5 volts exist between air mix door motor harness connector terminal Nos. 4, 5 and ground?														
														
<table border="1" style="margin: auto;"> <thead> <tr> <th rowspan="2">Air mix door operation</th> <th colspan="2">Terminal No.</th> <th rowspan="2">Voltage</th> </tr> <tr> <th>(+)</th> <th>(-)</th> </tr> </thead> <tbody> <tr> <td>Cold → Hot</td> <td>4</td> <td rowspan="2">Ground</td> <td rowspan="2">Approx. 10.5V</td> </tr> <tr> <td>Hot → Cold</td> <td>5</td> </tr> </tbody> </table>			Air mix door operation	Terminal No.		Voltage	(+)	(-)	Cold → Hot	4	Ground	Approx. 10.5V	Hot → Cold	5
Air mix door operation	Terminal No.			Voltage										
	(+)	(-)												
Cold → Hot	4	Ground	Approx. 10.5V											
Hot → Cold	5													
Yes or No														
Yes	▶	GO TO 4.												
No	▶	Replace A/C control unit.												

SHA327FA

GI

MA

EM

LC

EC

FE

CL

MT

AT

AX

SU

BR

ST

RS

BT

HA

SC

EL

IDX

4	CHECK CIRCUIT CONTINUITY BETWEEN AIR MIX DOOR MOTOR AND A/C CONTROL UNIT
<p>Check circuit continuity between air mix door motor harness connector terminal Nos. (4), 5 and A/C control unit harness connector terminal Nos. (22), 23.</p> <div style="text-align: center;"> </div> <p style="text-align: right;">RHA380H</p>	
<p>Continuity should exist. If OK, check harness for short.</p> <p style="text-align: center;">OK or NG</p>	
OK	▶ Replace air mix door motor.
NG	▶ Repair harness or connector.

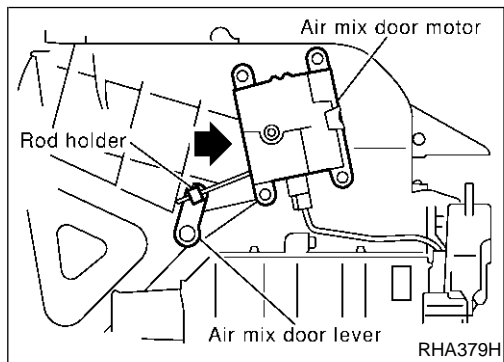

CONTROL LINKAGE ADJUSTMENT

NFHA0257

Air Mix Door

NFHA0257S01

1. Install air mix door motor on heater unit and connect it to main harness.
Make sure lever of air mix door is fitted into the slit of the air mix door link.
2. Turn ignition switch to ON.
3. Slide temperature control lever to full cold.
4. Check that air mix door operates properly when temperature control lever is slid to full hot and full cold.

Mode Door

TROUBLE DIAGNOSIS PROCEDURE FOR MODE DOOR

=NFHA0142

Symptom:

- Air outlet does not change.

Inspection Flow

1. Confirm symptom by performing the following operational check.

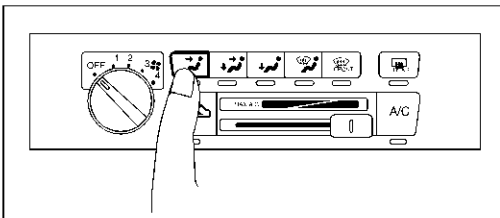

OPERATIONAL CHECK – Discharge air.

1) Push mode switch.

2) Confirm that discharge air comes out according to the air distribution table at left. Refer to “Discharge Air Flow” in “DESCRIPTION” (*4).

Discharge air flow

Mode switch	Mode door/distribution		
	Face	Foot	Defroster
	100%	–	–
	60%	40%	–
	–	80%	20%
	–	60%	40%
	–	–	100%

If OK (symptom cannot be duplicated), perform complete operational check. (*2)

If NG (symptom is confirmed), continue with STEP-2 following.

NOTE:

Confirm that the compressor clutch is engaged (visual inspection) and intake door position is at FRESH when the DEF mode is selected. Confirm that the intake door position is at FRESH when the D/F mode is selected.

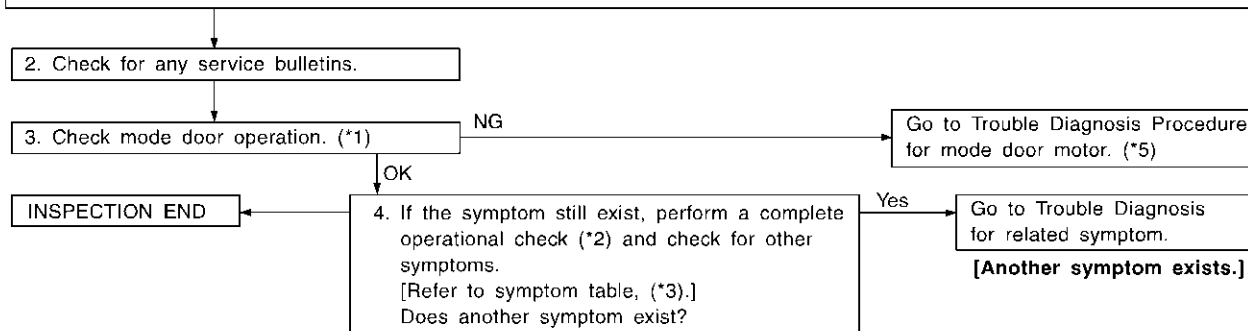

*1: HA-207
*2: HA-186

*3: HA-185
*4: HA-176

*5: HA-206

SHA784F

GI
MA
EM
LC
EC
FE
CL
MT
AT
AX
SU
BR
ST
RS
BT
HA
SC
EL
IDX

Mode Door (Cont'd)

=NFHA0260

DIAGNOSTIC PROCEDURE

SYMPTOM:

- Mode door motor does not operate normally.

1	CHECK POWER SUPPLY FOR A/C CONTROL UNIT	
Refer to "MAIN POWER SUPPLY AND GROUND CIRCUIT CHECK", HA-189.		
OK or NG		
OK	▶	GO TO 2.
NG	▶	Check A/C control unit power circuit. <ul style="list-style-type: none"> ● Check 10A fuses [Nos. 12 and 28, located in the fuse block (J/B)] ● If fuses are OK, check for open circuit in wiring harness. Repair or replace as necessary. ● If fuses are NG, replace and check wiring harness for short circuit. Repair or replace as necessary.

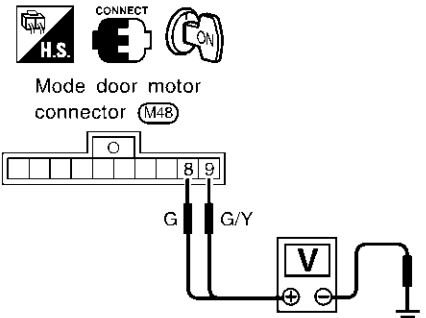
2	CHECK FOR OUTPUT OF A/C CONTROL UNIT													
Do approx. 10.5 volts exist between mode door motor harness connector terminal Nos. 8, 9 and ground?														
														
<table border="1" style="margin: auto;"> <thead> <tr> <th rowspan="2">Mode door operation</th> <th colspan="2">Terminal No.</th> <th rowspan="2">Voltage</th> </tr> <tr> <th>(+)</th> <th>(-)</th> </tr> </thead> <tbody> <tr> <td>VENT → DEF</td> <td style="text-align: center;">9</td> <td rowspan="2" style="text-align: center;">Ground</td> <td rowspan="2" style="text-align: center;">Approx. 10.5V</td> </tr> <tr> <td>DEF → VENT</td> <td style="text-align: center;">8</td> </tr> </tbody> </table>			Mode door operation	Terminal No.		Voltage	(+)	(-)	VENT → DEF	9	Ground	Approx. 10.5V	DEF → VENT	8
Mode door operation	Terminal No.			Voltage										
	(+)	(-)												
VENT → DEF	9	Ground	Approx. 10.5V											
DEF → VENT	8													
SHA328FA														
Yes or No														
Yes	▶	GO TO 3.												
No	▶	Replace A/C control unit.												

3 CHECK CIRCUIT CONTINUITY BETWEEN MODE DOOR MOTOR AND A/C CONTROL UNIT

Disconnect A/C control unit and mode door motor.
Check circuit continuity of each harness connector terminals between A/C control unit and mode door motor.

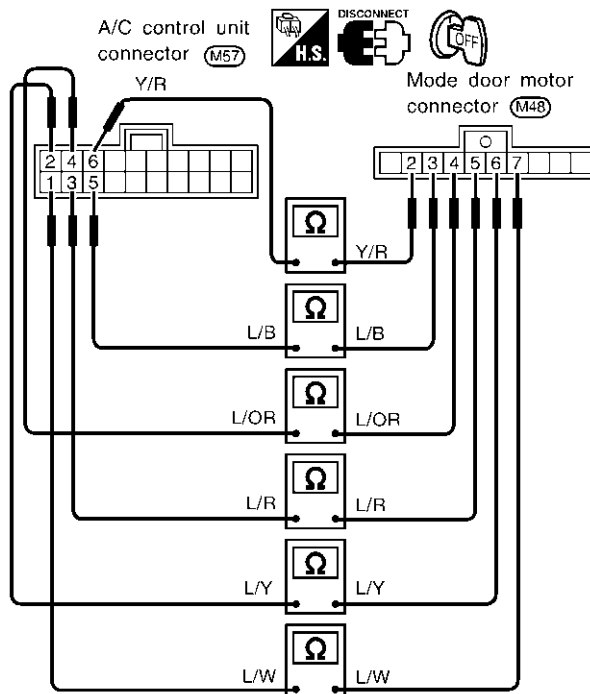

RHA395H

Continuity should exist.

If OK, check harness for short.

OK or NG

OK	▶	Replace mode door motor.
NG	▶	Repair harness or connector.

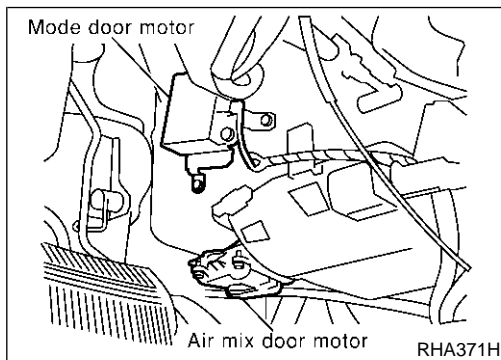

CONTROL LINKAGE ADJUSTMENT

NFHA0151

Mode Door

NFHA0151S01

1. Install mode door motor on heater unit and connect it to main harness.
Make sure lever of mode door motor is fitted into the slit of mode door link.
2. Turn ignition switch to ON.
3. Turn VENT switch ON.
4. Turn DEF switch ON. Check that slide link operates at the full-open position.
Also turn DEF switch ON to check that slide link operates at the fully-open position.

Magnet Clutch

TROUBLE DIAGNOSIS PROCEDURE FOR MAGNET CLUTCH

=NFHA0119

Symptom:

- Magnet clutch does not operate when A/C switch and fan switch are ON.

Inspection Flow

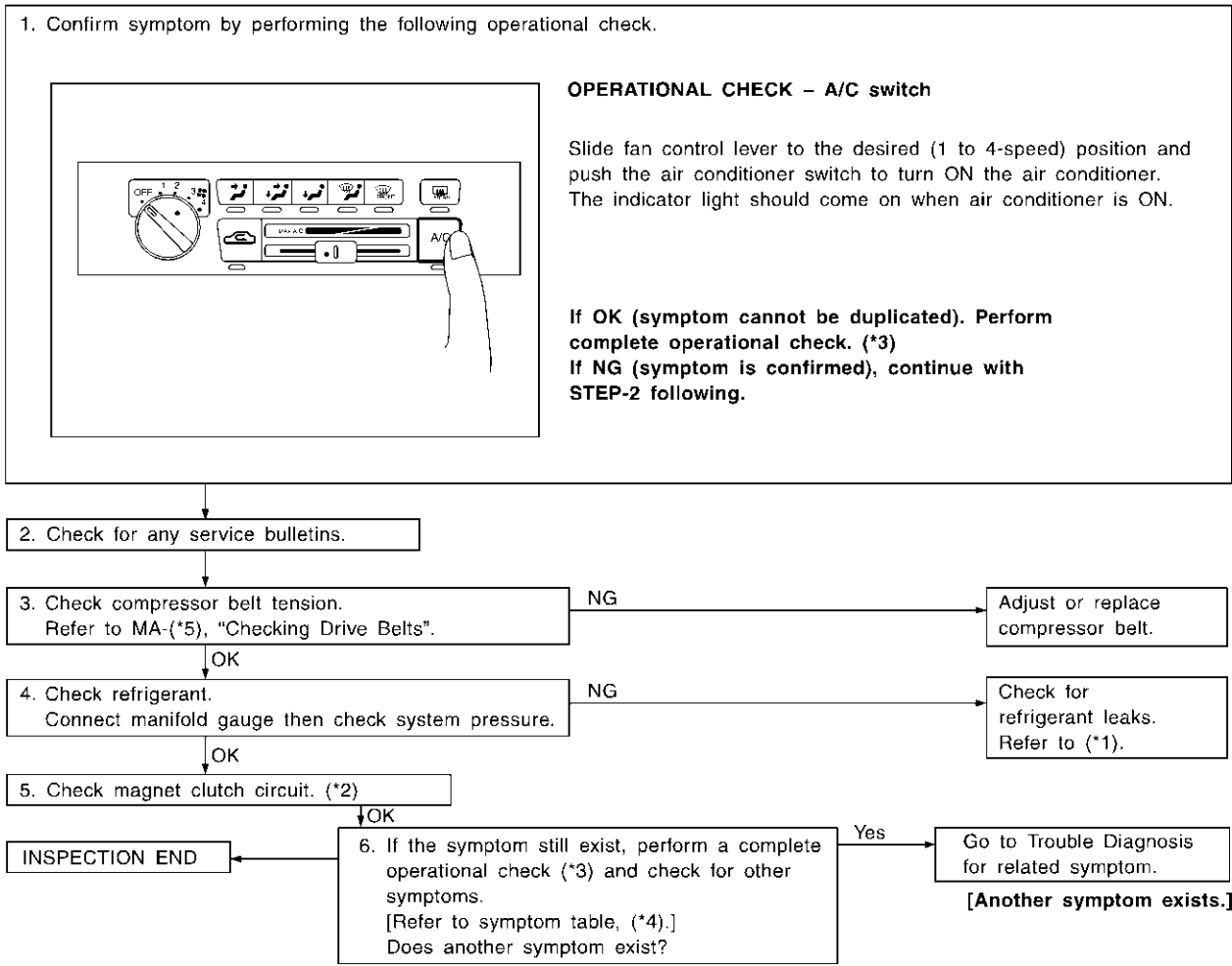

SHA785F

*1: HA-238

*3: HA-186

*5: MA-13

*2: HA-209

*4: HA-185

DIAGNOSTIC PROCEDURE

=NFHA0091

SYMPTOM:

- Magnet clutch does not engage when A/C switch and fan switch are ON.

1	CHECK POWER SUPPLY FOR COMPRESSOR		
		Disconnect compressor harness connector. Do approx. 12 volts exist between compressor harness connector terminal No. 1 and ground?	
		<p style="text-align: center;">Compressor connector (A3)</p>	RHA747FI
		Yes or No	
Yes	▶	GO TO 2.	
No	▶	Disconnect A/C relay. GO TO 3.	

2	CHECK MAGNET CLUTCH COIL		
		OK or NG	
NG	▶	Replace magnet clutch. Refer to HA-231.	

3	CHECK CIRCUIT CONTINUITY BETWEEN A/C RELAY AND COMPRESSOR		
		Check circuit continuity between A/C relay harness connector terminal No. 3 and compressor harness connector terminal No. 1	
		<p style="text-align: center;">Compressor connector (A3) A/C relay connector (E71)</p>	RHA400HA
		OK or NG	
		Continuity should exist.	
		If OK, check harness for short.	
OK	▶	GO TO 4.	
NG	▶	Repair harness or connector.	

Magnet Clutch (Cont'd)

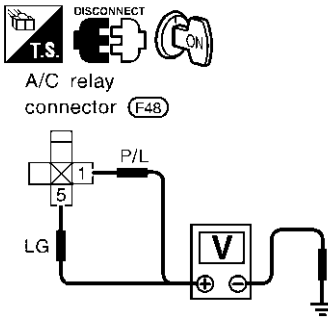
4	CHECK POWER SUPPLY FOR A/C RELAY	
<p>Disconnect A/C relay. Do approx. 12 volts exist between A/C relay harness connector terminal Nos. 1, 5 and ground?</p>		
		
RHA439H		
Yes or No		
Yes	▶	GO TO 5.
No	▶	<p>Check power supply circuit and 10A fuses (Nos. 28, 66 located in the fuse and fusible link box). Refer to EL-12, "Wiring Diagram — POWER —". If OK, check for open circuit in wiring harness. Repair or replace as necessary. If NG, replace fuse and check wiring harness for short circuit. Repair or replace as necessary.</p>

5	CHECK A/C RELAY AFTER DISCONNECTING IT	
Refer to HA-214.		
OK or NG		
OK	▶	Reconnect A/C relay. GO TO 6.
NG	▶	Replace A/C relay.

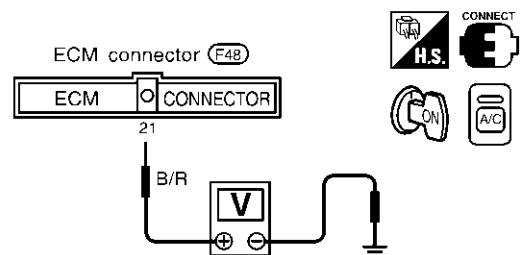
6	CHECK COIL SIDE CIRCUIT OF A/C RELAY	
Do approx. 0 volts exist between ECM harness connector terminal No. 21 and ground?		
		
RHA0811		
Yes or No		
Yes	▶	GO TO 8.
No	▶	Disconnect A/C relay. Disconnect ECM harness connector. GO TO 7.

7	CHECK CIRCUIT CONTINUITY BETWEEN A/C RELAY AND ECM	
<p>Check circuit continuity between A/C relay harness connector terminal No. 2 and ECM harness connector terminal No. 21.</p> <div style="text-align: center;"> <p>A/C relay connector (E71) ECM connector (F48)</p> </div> <p style="text-align: right;">RHA0821</p> <p>Continuity should exist. Check harness for short.</p> <p style="text-align: center;">OK or NG</p>		
OK	▶	Check ECM. Refer to EC-140, "ECM Terminals and Reference Value".
NG	▶	Repair harness or connector. INSPECTION END.

8	CHECK REFRIGERANT PRESSURE SENSOR INPUT SIGNAL	
<p>Do approx. 4.6 volts between ECM harness connector terminal No. 30 and ground?</p> <div style="text-align: center;"> <p>ECM connector (F48)</p> </div> <p style="text-align: right;">RHA0831</p> <p style="text-align: center;">Yes or No</p>		
Yes	▶	GO TO 9.
No	▶	Check ECM. Refer to EC-140, "ECM Terminals and Reference Value". Repair harness or connector.

9	CHECK REFRIGERANT PRESSURE SENSOR	
<p>Refer to HA-214.</p> <p style="text-align: center;">OK or NG</p>		
OK	▶	Disconnect A/C switch harness connector. GO TO 10.
NG	▶	Replace refrigerant pressure sensor.

GI
MA
EM
LC
EC
FE
CL
MT
AT
AX
SU
BR
ST
RS
BT
HA
SC
EL
IDX

10	CHECK VOLTAGE FOR ECM	
<p>Do approx. 0 volts exist between ECM harness connector terminal No. 45 and ground?</p> <div style="text-align: center;"> </div> <p style="text-align: right;">SHA312F</p>		
Yes or No		
Yes	▶	GO TO 11.
No	▶	Check ECM. Refer to EC-140, "ECM Terminals and Reference Value". Repair harness or connector.

11	CHECK CIRCUIT CONTINUITY BETWEEN A/C CONTROL UNIT AND FAN SWITCH	
<p>Check circuit continuity between A/C control unit harness connector terminal No. 12 and fan switch harness terminal No. 6.</p> <div style="text-align: center;"> </div> <p style="text-align: right;">RHA450H</p>		
Continuity should exist. If OK, check harness for short.		
OK or NG		
OK	▶	GO TO 12.
NG	▶	Repair harness or connector.

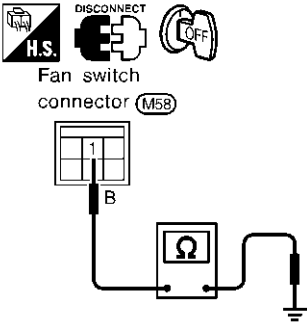
12	CHECK BODY GROUND CIRCUIT FOR FAN SWITCH	
Does continuity exist between fan switch harness terminal No. 1 and ground?		
 <p style="text-align: center;">Fan switch connector (M58)</p>		
RHA451H		
Yes or No		
Yes	▶	GO TO 13.
No	▶	Repair harness or connector.

13	CHECK FAN SWITCH	
Refer to HA-196.		
OK or NG		
OK	▶	Replace A/C control unit.
NG	▶	Replace fan switch.

GI
 MA
 EM
 LC
 EC
 FE
 CL
 MT
 AT
 AX
 SU
 BR
 ST
 RS
 BT
 HA
 SC
 EL
 IDX

Magnet Clutch (Cont'd)

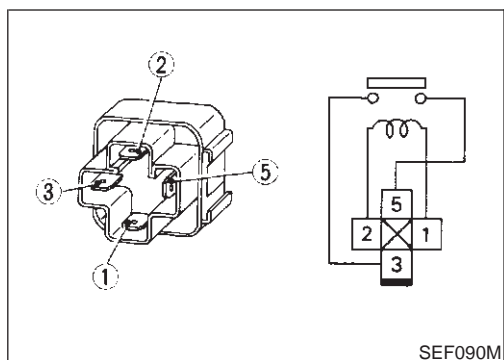

ELECTRICAL COMPONENTS INSPECTION

=NFHA0092

A/C Relay

NFHA0092S07

Check continuity between terminal Nos. 3 and 5.

Conditions	Continuity
12V direct current supply between terminal Nos. 1 and 2	Yes
No current supply	No

If NG, replace relay.

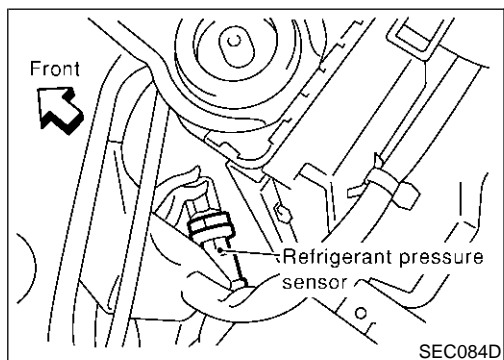

Refrigerant Pressure Sensor

NFHA0092S08

The refrigerant pressure sensor is located on the condenser. Refer to EC-718, "Diagnostic Procedure".

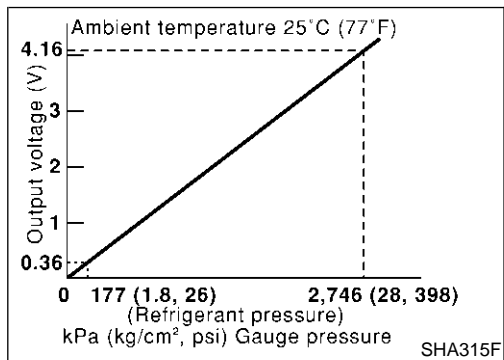
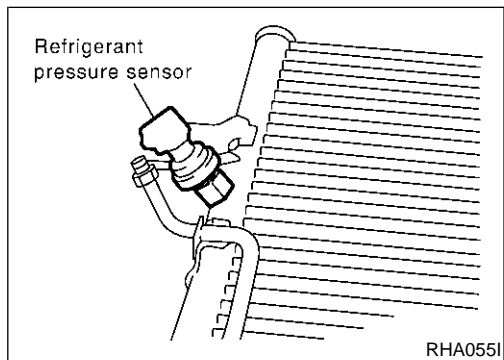

Make sure that higher A/C refrigerant pressure results in higher refrigerant-pressure sensor output voltage.

Insufficient Cooling

TROUBLE DIAGNOSIS PROCEDURE FOR INSUFFICIENT COOLING

=NFHA0150

Symptom:

- Insufficient Cooling.

Inspection Flow

GI

MA

EM

LC

EC

FE

CL

MT

AT

AX

SU

BR

ST

RS

BT

HA

SC

EL

IDX

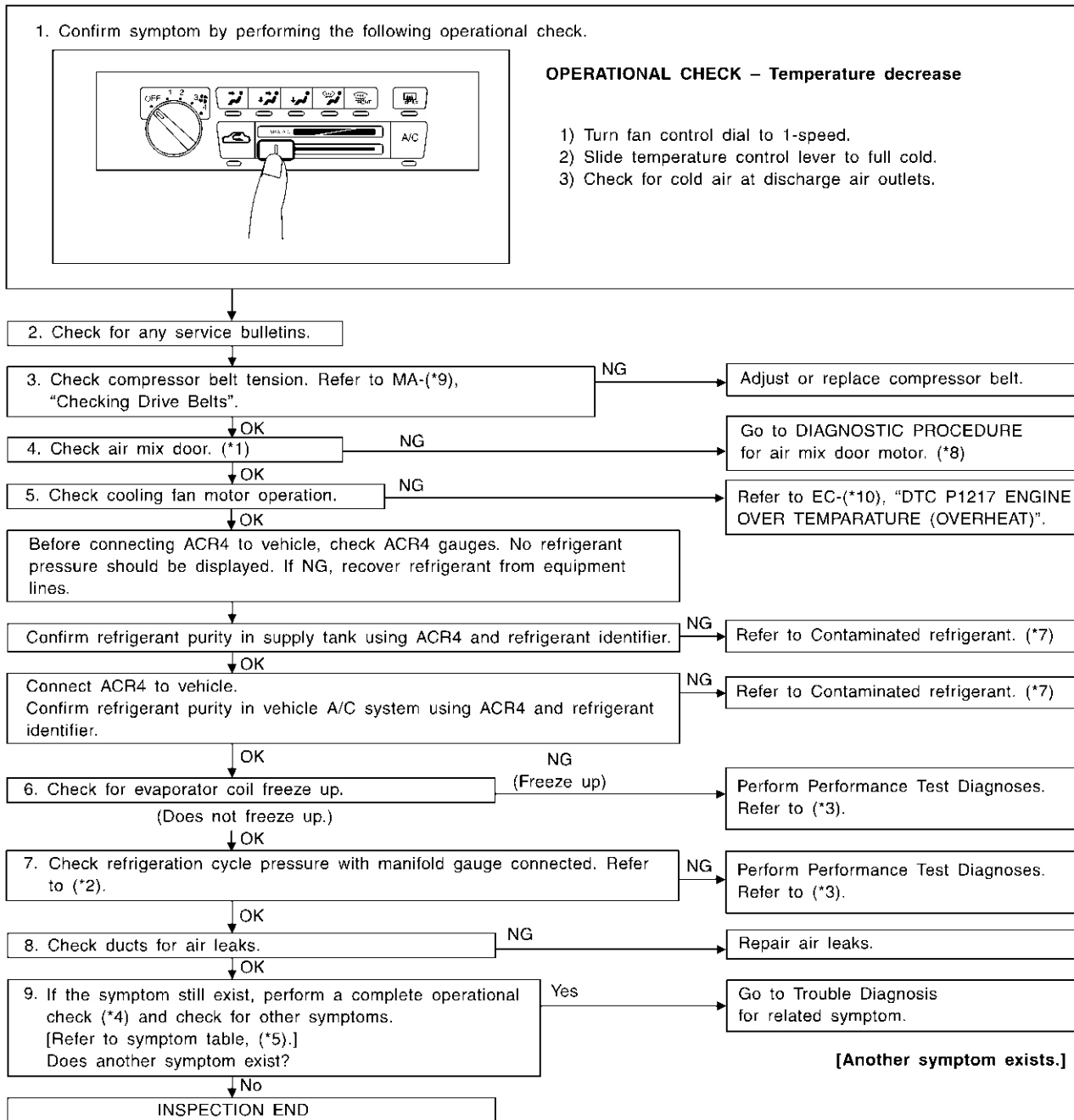

*1: HA-201
 *2: HA-218
 *3: HA-216
 *4: HA-186

*5: HA-185
 *6: HA-231
 *7: HA-157

*8: HA-201
 *9: MA-13
 *10: EC-515

SHA642FA

PERFORMANCE TEST DIAGNOSES

NFHA0082

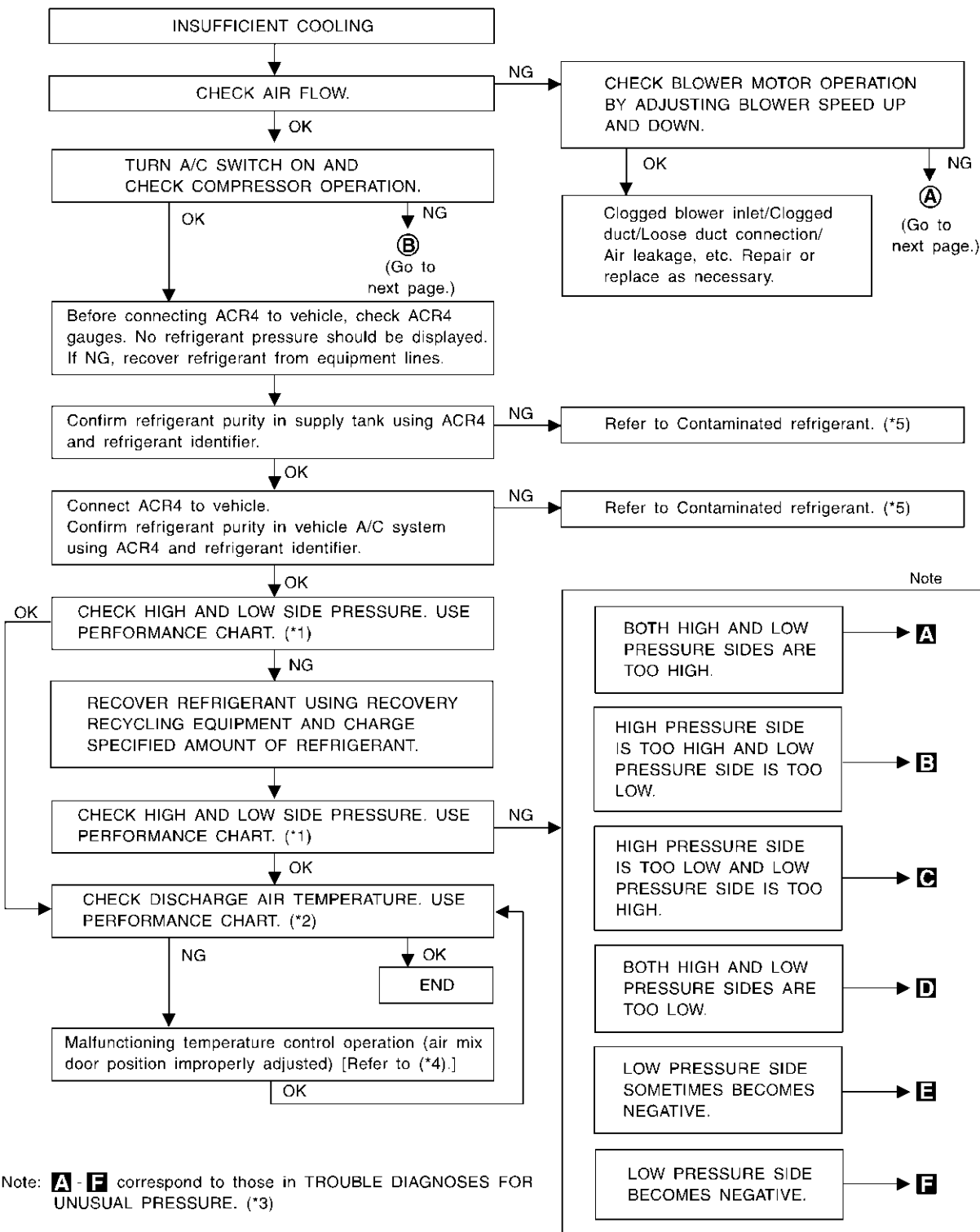

SHA333FA

*1: HA-218
*2: HA-218

*3: HA-219
*4: HA-201

*5: HA-157

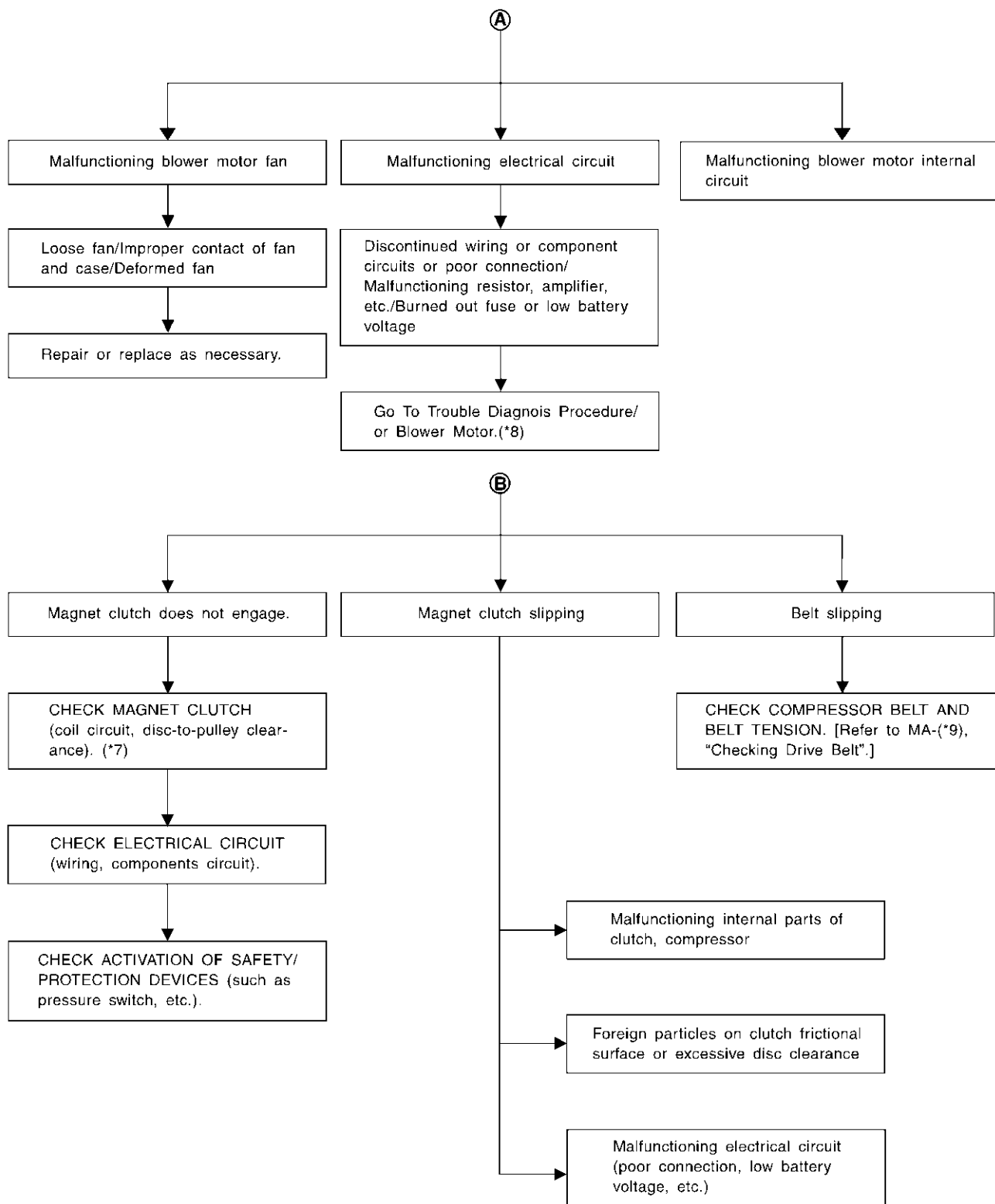

GI

MA

EM

LC

EC

FE

CL

MT

AT

AX

SU

BR

ST

RS

BT

HA

SC

EL

IDX

SHA334F

*7: HA-233

*8: HA-195

*9: MA-13

Insufficient Cooling (Cont'd)

PERFORMANCE TEST

=NFHA0083

Test Condition

NFHA0083S01

Testing must be performed as follows:

Vehicle location	Indoors or in the shade (in a well-ventilated place)
Doors	Closed
Door windows	Open
Hood	Open
TEMP.	Max. COLD
Discharge Air	Face Vent
REC switch	 (Recirculation) set
FAN speed	High speed
Engine speed	Idle speed

Operate the air conditioning system for 10 minutes before taking measurements.

Test Reading

NFHA0083S02

Recirculating-to-discharge Air Temperature Table

NFHA0083S0201

Inside air (Recirculating air) at blower assembly inlet		Discharge air temperature at center ventilator °C (°F)
Relative humidity %	Air temperature °C (°F)	
50 - 60	15 (59)	3.5 - 5.4 (38 - 42)
	20 (68)	6.6 - 8.9 (44 - 48)
	25 (77)	9.5 - 12.6 (49 - 55)
	30 (86)	13.4 - 16.5 (56 - 62)
	35 (95)	17.6 - 21.3 (64 - 70)
60 - 70	15 (59)	5.4 - 7.1 (42 - 45)
	20 (68)	8.9 - 11.0 (48 - 52)
	25 (77)	12.6 - 15.4 (55 - 60)
	30 (86)	16.5 - 20.0 (62 - 68)
	35 (95)	21.3 - 24.8 (70 - 77)

Ambient Air Temperature-to-operating Pressure Table

NFHA0083S0202

Ambient air		High-pressure (Discharge side) kPa (kg/cm ² , psi)	Low-pressure (Suction side) kPa (kg/cm ² , psi)
Relative humidity %	Air temperature °C (°F)		
50 - 70	15 (59)	539 - 657 (5.5 - 6.7, 78 - 95)	167 - 206 (1.7 - 2.1, 24 - 30)
	20 (68)	677 - 824 (6.9 - 8.4, 98 - 119)	177 - 216 (1.8 - 2.2, 26 - 31)
	25 (77)	843 - 1,030 (8.6 - 10.5, 122 - 149)	177 - 226 (1.8 - 2.3, 26 - 33)
	30 (86)	1,030 - 1,275 (10.5 - 13.0, 149 - 185)	216 - 255 (2.2 - 2.6, 31 - 37)
	35 (95)	1,245 - 1,520 (12.7 - 15.5, 181 - 220)	265 - 324 (2.7 - 3.3, 38 - 47)

TROUBLE DIAGNOSES FOR UNUSUAL PRESSURE

NFHA0084

Whenever system's high and/or low side pressure is unusual, diagnose using a manifold gauge. The marker above the gauge scale in the following tables indicates the standard (normal) pressure range. Since the standard (normal) pressure, however, differs from vehicle to vehicle, refer to HA-218 ("Ambient air temperature-to-operating pressure table").

Both High and Low-pressure Sides are Too High.

NFHA0084S01

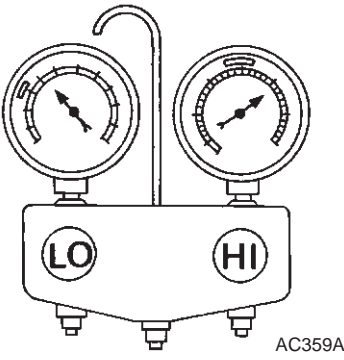
Gauge indication	Refrigerant cycle	Probable cause	Corrective action
Both high and low-pressure sides are too high. A	<ul style="list-style-type: none"> Pressure is reduced soon after water is splashed on condenser. 	Excessive refrigerant charge in refrigeration cycle	Reduce refrigerant until specified pressure is obtained.
	Air suction by cooling fan is insufficient.	Insufficient condenser cooling performance ↓ 1. Condenser fins are clogged. 2. Improper fan rotation of cooling fan	<ul style="list-style-type: none"> Clean condenser. Check and repair cooling fan as necessary.
	<ul style="list-style-type: none"> Low-pressure pipe is not cold. When compressor is stopped high-pressure value quickly drops by approximately 196 kPa (2 kg/cm², 28 psi). It then decreases gradually thereafter. 	Poor heat exchange in condenser (After compressor operation stops, high pressure decreases too slowly.) ↓ Air in refrigeration cycle	Evacuate repeatedly and recharge system.
	Engine tends to overheat.	Engine cooling systems malfunction.	Check and repair each engine cooling system.
	<ul style="list-style-type: none"> An area of the low-pressure pipe is colder than areas near the evaporator outlet. Plates are sometimes covered with frost. 	<ul style="list-style-type: none"> Excessive liquid refrigerant on low-pressure side Excessive refrigerant discharge flow Expansion valve is open a little compared with the specification. ↓ 1. Improper expansion valve installation 2. Improper expansion valve adjustment	Replace expansion valve.

GI

MA

EM

LC

EC

FE

CL

MT

AT

AX

SU

BR

ST

RS

BT

HA

SC

EL

IDX

Insufficient Cooling (Cont'd)

High-pressure Side is Too High and Low-pressure Side is Too Low.

NFHA0084S02

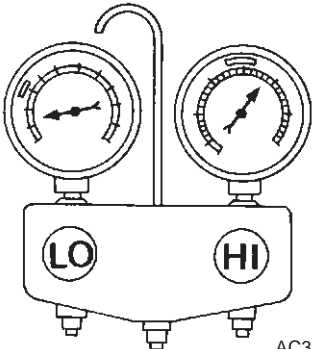
Gauge indication	Refrigerant cycle	Probable cause	Corrective action
<p>High-pressure side is too high and low-pressure side is too low.</p> <p>B</p>  <p>AC360A</p>	<p>Upper side of condenser and high-pressure side are hot, however, liquid tank is not so hot.</p>	<p>High-pressure tube or parts located between compressor and condenser are clogged or crushed.</p>	<ul style="list-style-type: none"> ● Check and repair or replace malfunctioning parts. ● Check lubricant for contamination.

High-pressure Side is Too Low and Low-pressure Side is Too High.

NFHA0084S03

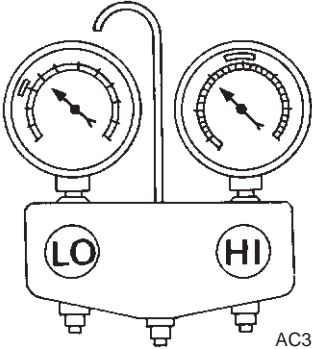
Gauge indication	Refrigerant cycle	Probable cause	Corrective action
<p>High-pressure side is too low and low-pressure side is too high.</p> <p>C</p>  <p>AC356A</p>	<p>High and low-pressure sides become equal soon after compressor operation stops.</p>	<p>Compressor pressure operation is improper.</p> <p>↓</p> <p>Damaged inside compressor packings.</p>	<p>Replace compressor.</p>
	<p>No temperature difference between high and low-pressure sides</p>	<p>Compressor pressure operation is improper.</p> <p>↓</p> <p>Damaged inside compressor packings.</p>	<p>Replace compressor.</p>

Both High- and Low-pressure Sides are Too Low.

NFHA0084S04

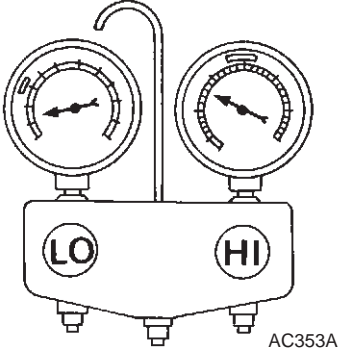
Gauge indication	Refrigerant cycle	Probable cause	Corrective action
<p>Both high- and low-pressure sides are too low.</p> <p>D</p>  <p style="text-align: right; margin-right: 20px;">AC353A</p>	<ul style="list-style-type: none"> • There is a big temperature difference between receiver drier outlet and inlet. Outlet temperature is extremely low. • Liquid tank inlet and expansion valve are frosted. 	<p>Compressor discharge capacity does not change. (Compressor stroke is set at maximum.)</p>	<ul style="list-style-type: none"> • Replace liquid tank. • Check lubricant for contamination.
	<ul style="list-style-type: none"> • Temperature of expansion valve inlet is extremely low as compared with areas near liquid tank. • Expansion valve inlet may be frosted. • Temperature difference occurs somewhere in high-pressure side 	<p>High-pressure pipe located between receiver drier and expansion valve is clogged.</p>	<ul style="list-style-type: none"> • Check and repair malfunctioning parts. • Check lubricant for contamination.
	<ul style="list-style-type: none"> • Expansion valve and liquid tank are warm or only cool when touched. 	<p>Low refrigerant charge</p> <p style="text-align: center;">↓</p> <p>Leaking fittings or components</p>	<p>Check refrigerant for leaks. Refer to "Checking Refrigerant Leaks", HA-238.</p>
	<p>There is a big temperature difference between expansion valve inlet and outlet while the valve itself is frosted.</p>	<p>Expansion valve closes a little compared with the specification.</p> <p style="text-align: center;">↓</p> <ol style="list-style-type: none"> 1. Improper expansion valve adjustment 2. Malfunctioning expansion valve 3. Outlet and inlet may be clogged. 	<ul style="list-style-type: none"> • Remove foreign particles by using compressed air. • Check lubricant for contamination.
	<p>An area of the low-pressure pipe is colder than areas near the evaporator outlet.</p>	<p>Low-pressure pipe is clogged or crushed.</p>	<ul style="list-style-type: none"> • Check and repair malfunctioning parts. • Check lubricant for contamination.
	<p>Air flow volume is not enough or is too low.</p>	<p>Evaporator is frozen.</p> <p style="text-align: center;">↓</p> <p>Compressor discharge capacity does not change. (Compressor stroke is set at maximum length.)</p>	<p>Replace compressor.</p>

GI

MA

EM

LC

EC

FE

CL

MT

AT

AX

SU

BR

ST

RS

BT

HA

SC

EL

IDX

Low-pressure Side Sometimes Becomes Negative.

NFHA0084S05

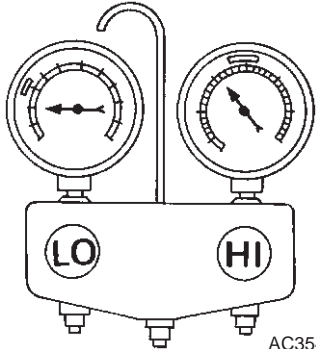
Gauge indication	Refrigerant cycle	Probable cause	Corrective action
<p>Low-pressure side sometimes becomes negative.</p> <p>E</p>  <p>AC354A</p>	<ul style="list-style-type: none"> • Air conditioning system does not function and does not cyclically cool the compartment air. • The system constantly functions for a certain period of time after compressor is stopped and restarted. 	<p>Refrigerant does not discharge cyclically.</p> <p>↓</p> <p>Moisture is frozen at expansion valve outlet and inlet.</p> <p>↓</p> <p>Water is mixed with refrigerant.</p>	<ul style="list-style-type: none"> • Drain water from refrigerant or replace refrigerant. • Replace liquid tank.

Low-pressure Side Becomes Negative.

NFHA0084S06

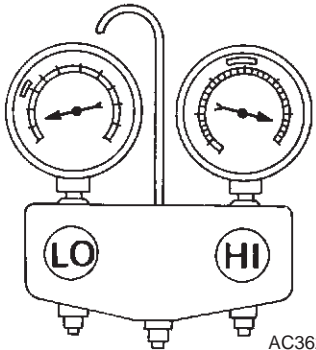
Gauge indication	Refrigerant cycle	Probable cause	Corrective action
<p>Low-pressure side becomes negative.</p> <p>F</p>  <p>AC362A</p>	<p>Liquid tank or front/rear side of expansion valve's pipe is frosted or dewed.</p>	<p>High-pressure side is closed and refrigerant does not flow.</p> <p>↓</p> <p>Expansion valve or liquid tank is frosted.</p>	<p>Leave the system at rest until no frost is present. Start it again to check whether or not the problem is caused by water or foreign particles.</p> <ul style="list-style-type: none"> • If water is the cause, initially cooling is okay. Then the water freezes causing a blockage. Drain water from refrigerant or replace refrigerant. • If due to foreign particles, remove expansion valve and remove particles with dry and compressed air (not shop air). • If either of the above methods cannot correct the problem, replace expansion valve. • Replace liquid tank. • Check lubricant for contamination.

Insufficient Heating

TROUBLE DIAGNOSIS PROCEDURE FOR INSUFFICIENT HEATING

=NFHA0140

Symptom:

- Insufficient Heating.

Inspection Flow

GI

MA

EM

LC

EC

FE

CL

MT

AT

AX

SU

BR

ST

RS

BT

HA

SC

EL

IDX

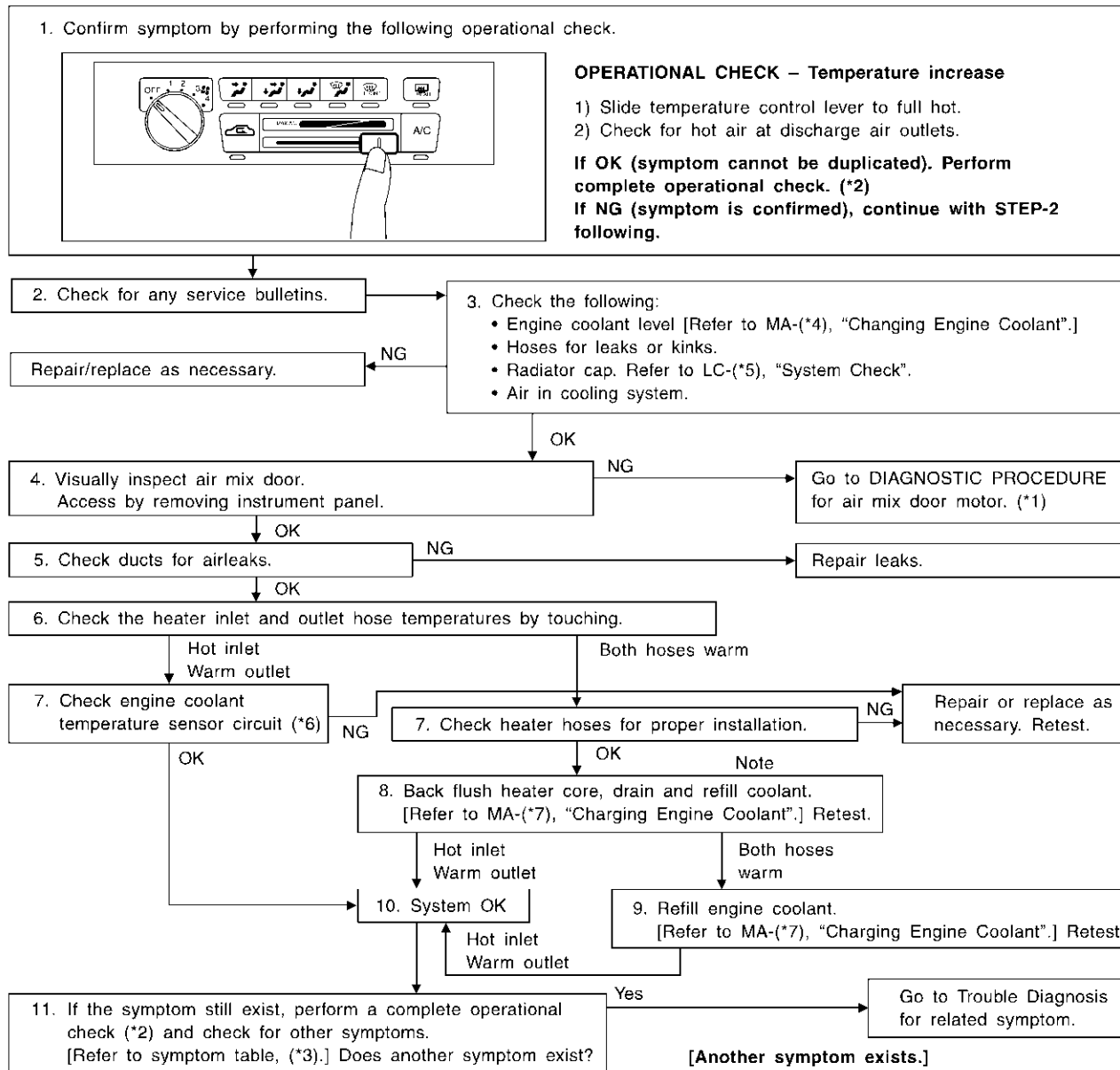

SHA782F

*1: HA-201
*2: HA-186
*3: HA-185

*4: MA-14
*5: LC-13

*6: EC-224
*7: MA-14

Noise
TROUBLE DIAGNOSIS PROCEDURE FOR NOISE

=NFHA0080

Symptom:

- Noise

Inspection Flow

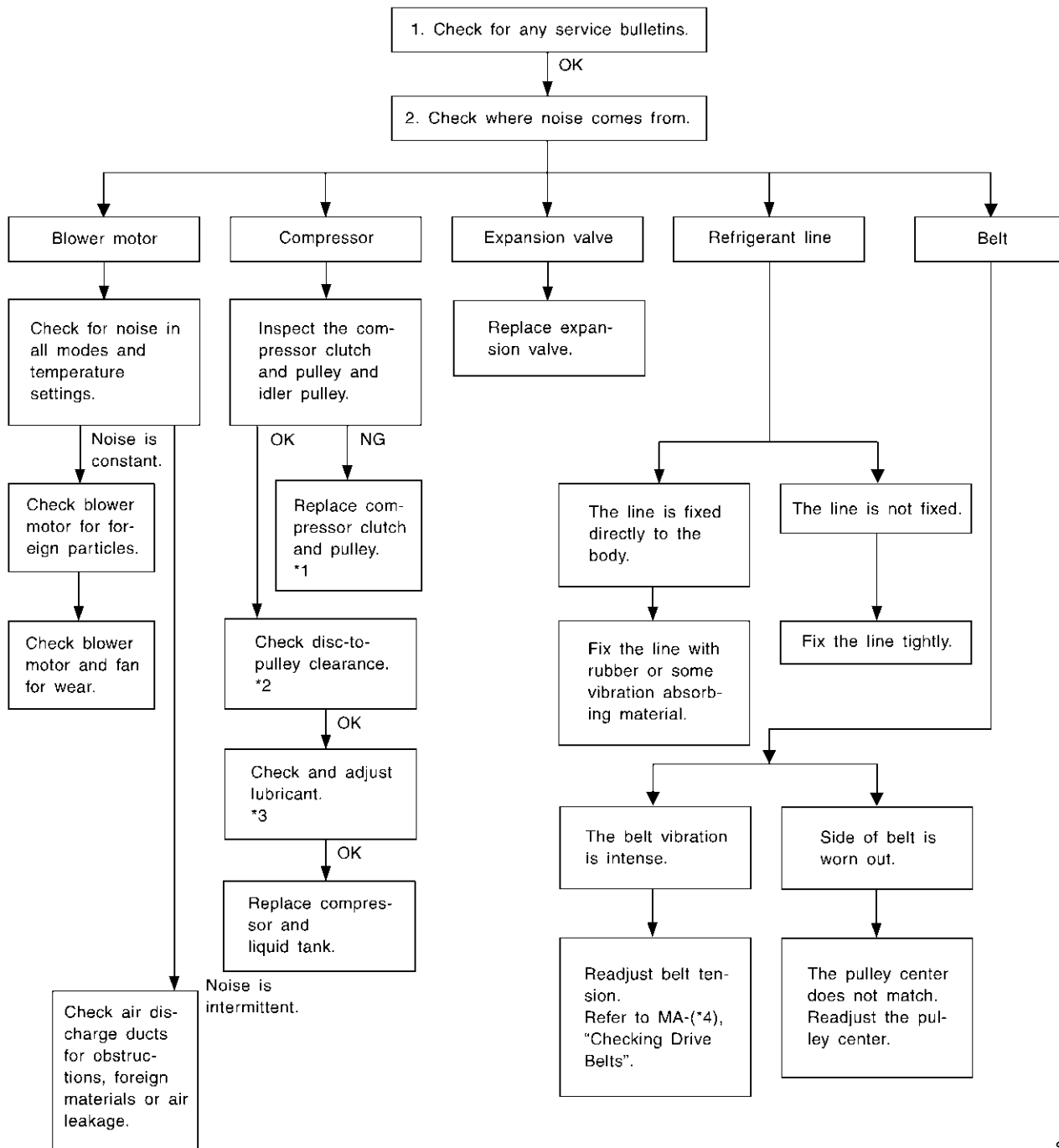

SHA336F

*1: HA-233

*3: HA-227

*4: MA-13

*2: HA-233

HFC-134a (R-134a) Service Procedure

NFHA0094

NFHA0094S01

NFHA0094S0101

SETTING OF SERVICE TOOLS AND EQUIPMENT

Discharging Refrigerant

WARNING:

Avoid breathing A/C refrigerant and lubricant vapor or mist. Exposure may irritate eyes, nose and throat. Remove HFC-134a (R-134a) from A/C system using certified service equipment meeting requirements of SAE J2210 (R-134a recycling equipment) or J2209 (R-134a recovery equipment). If accidental system discharge occurs, ventilate work area before resuming service. Additional health and safety information may be obtained from refrigerant and lubricant manufacturers.

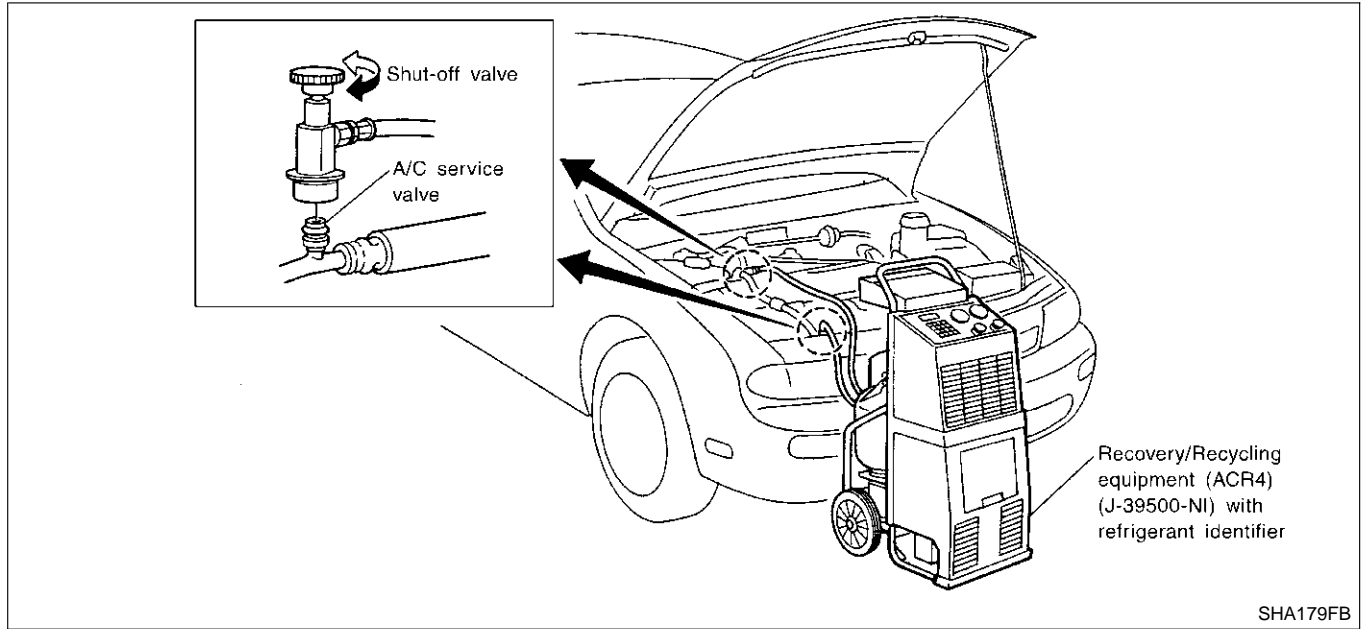

Evacuating System and Charging Refrigerant

NFHA0094S0102

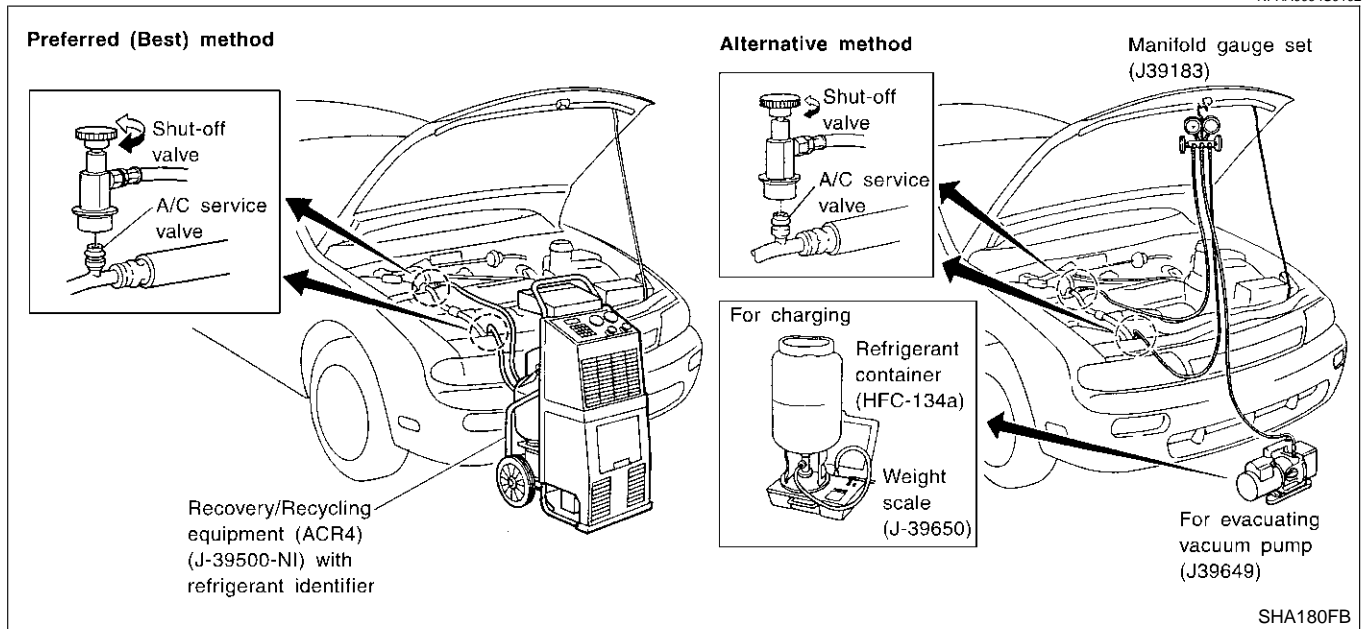

Recovered lubricant. Refer to "CHECKING AND ADJUSTING", *1.

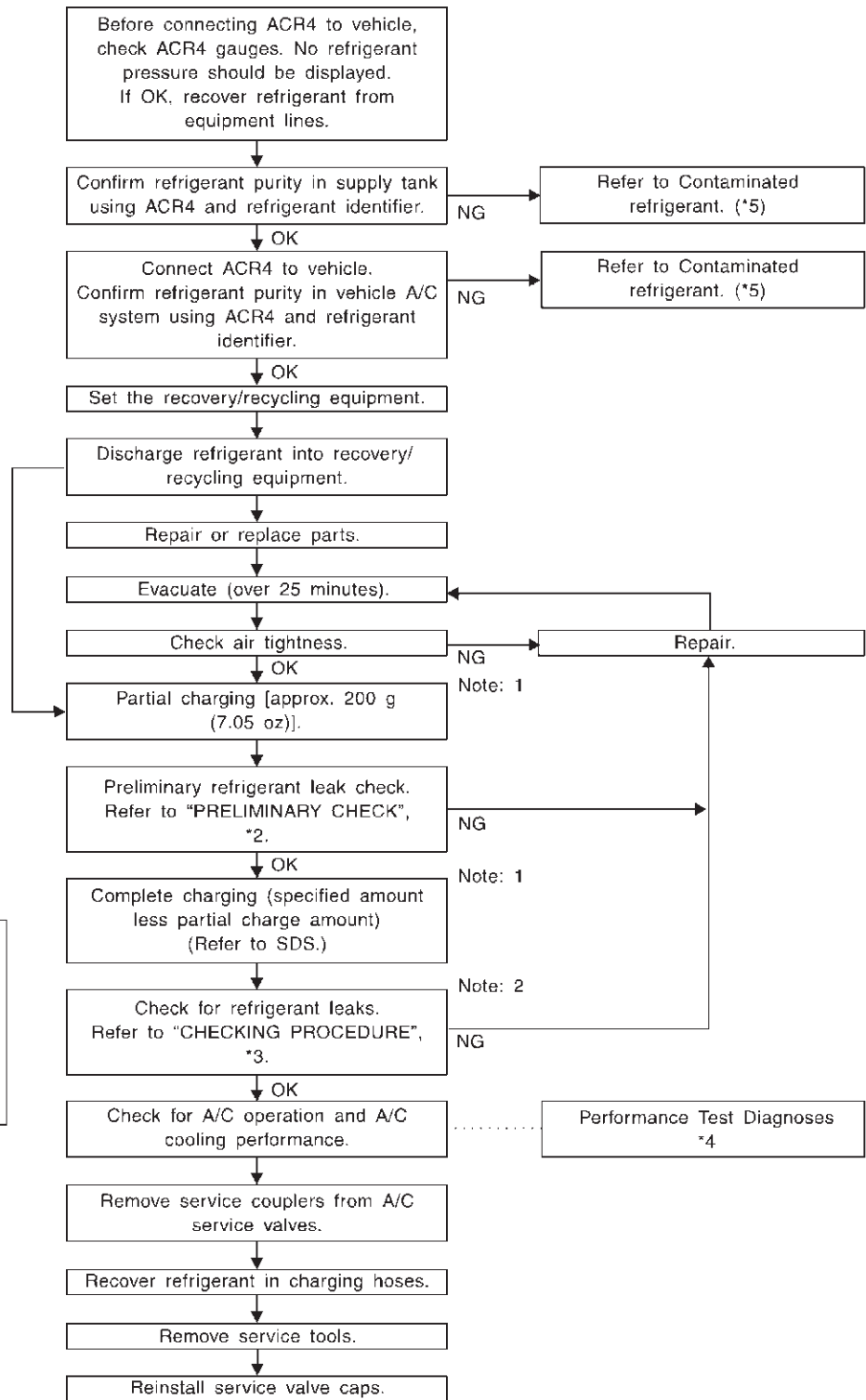

Note: 1 Before charging refrigerant, ensure engine is off.
 Note: 2 Before checking for leaks, start engine to activate air conditioning system then turn engine off. Service valve caps must be installed to prevent leakage.

*1: HA-227
 *2: HA-238

*3: HA-239
 *4: HA-216

*5: HA-157

Maintenance of Lubricant Quantity in Compressor

NFHA0095

The lubricant in the compressor circulates through the system with the refrigerant. Add lubricant to compressor when replacing any component or after a large gas leakage occurred. It is important to maintain the specified amount. If lubricant quantity is not maintained properly, the following malfunctions may result:

- Lack of lubricant: May lead to a seized compressor
- Excessive lubricant: Inadequate cooling (thermal exchange interference)

LUBRICANT

NFHA0095S01

Name: Nissan A/C System Oil Type S
Part number: KLH00-PAGS0

CHECKING AND ADJUSTING

NFHA0095S02

Adjust the lubricant quantity according to the test group shown below.

1	LUBRICANT RETURN OPERATION	
Can lubricant return operation be performed?		
<ul style="list-style-type: none"> ● A/C system works properly. ● There is no evidence of a large amount of lubricant leakage. 		
Yes or No		
Yes	▶	GO TO 2.
No	▶	GO TO 3.

2	PERFORM LUBRICANT RETURN OPERATION, PROCEEDING AS FOLLOWS	
<p>1. Start engine, and set the following conditions:</p> <p>Test condition Engine speed: Idling to 1,200 rpm A/C switch: ON Blower speed: Max. position Temp. control: Optional [Set so that intake air temperature is 25 to 30°C (77 to 86°F).]</p> <p>2. Next item is for V-6 compressor. Connect the manifold gauge, and check that the high pressure side pressure is 588 kPa (6 kg/cm², 85 psi) or higher. If less than the reference level, attach a cover to the front face of the condenser to raise the pressure.</p> <p>3. Perform lubricant return operation for about 10 minutes.</p> <p>4. Stop engine.</p> <p>CAUTION: If excessive lubricant leakage is noted, do not perform the lubricant return operation.</p>		
	▶	GO TO 3.

3	CHECK COMPRESSOR	
Should the compressor be replaced?		
Yes or No		
Yes	▶	GO TO HA-229.
No	▶	GO TO 4.

GI
MA
EM
LC
EC
FE
CL
MT
AT
AX
SU
BR
ST
RS
BT
HA
SC
EL
IDX

Maintenance of Lubricant Quantity in Compressor (Cont'd)

4	CHECK ANY PART
Is there any part to be replaced? (Evaporator, condenser, liquid tank or in case there is evidence of a large amount of lubricant leakage.)	
Yes or No	
Yes	▶ GO TO HA-229.
No	▶ Carry out the A/C performance test.

Lubricant Adjusting Procedure for Components Replacement Except Compressor

=NFHA0095S0201

After replacing any of the following major components, add the correct amount of lubricant to the system.
Amount of lubricant to be added

Part replaced	Lubricant to be added to system	Remarks
	Amount of lubricant mℓ (US fl oz, Imp fl oz)	
Evaporator	75 (2.5, 2.6)	—
Condenser	75 (2.5, 2.6)	—
Liquid tank	5 (0.2, 0.2)	Add if compressor is not replaced. *1
In case of refrigerant leak	30 (1.0, 1.1)	Large leak
	—	Small leak *2

*1: If compressor is replaced, addition of lubricant is included in the table.

*2: If refrigerant leak is small, no addition of lubricant is needed.

Lubricant Adjustment Procedure for Compressor Replacement

NFHA0095S0202

- Before connecting ACR4 to vehicle, check ACR4 gauges. No refrigerant pressure should be displayed. If OK, recover refrigerant from equipment lines.
- Confirm refrigerant purity in supply tank using ACR4 and refrigerant identifier. If NG, refer to "CONTAMINATED REFRIGERANT", HA-157.
- Connect ACR4 to vehicle. Confirm refrigerant purity in vehicle A/C system using ACR4 and refrigerant identifier. If NG, refer to "CONTAMINATED REFRIGERANT", HA-157.
- Discharge refrigerant into the refrigerant recovery/recycling equipment. Measure lubricant discharged into the recovery/recycling equipment.
- Remove the drain plug of the "old" (removed) compressor. Drain the lubricant into a graduated container and record the amount of drained lubricant.
- Remove the drain plug and drain the lubricant from the "new" compressor into a separate, clean container.
- Measure an amount of new lubricant installed equal to amount drained from "old" compressor. Add this lubricant to "new" compressor through the suction port opening.
- Measure an amount of new lubricant equal to the amount recovered during discharging. Add this lubricant to "new" compressor through the suction port opening.
- Torque the drain plug.
V-6 compressor:
18 - 19 N·m (1.8 - 1.9 kg·m, 13 - 14 ft·lb)
- If the liquid tank also needs to be replaced, add an additional 5 mℓ (0.2 US fl oz, 0.2 Imp fl oz) of lubricant at this time. Do not add this 5 mℓ (0.2 US fl oz, 0.2 Imp fl oz) of lubricant if only replacing the compressor.

Lubricant adjusting procedure for compressor replacement

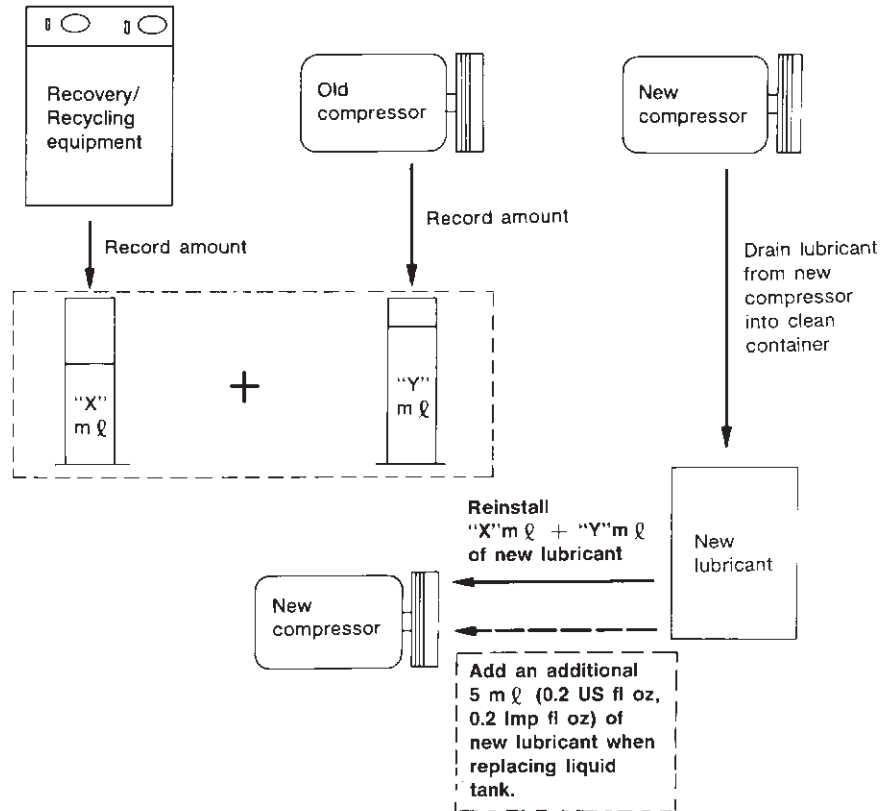

RHA065DD

Compressor REMOVAL AND INSTALLATION

NFHA0096

SEC. 274•275

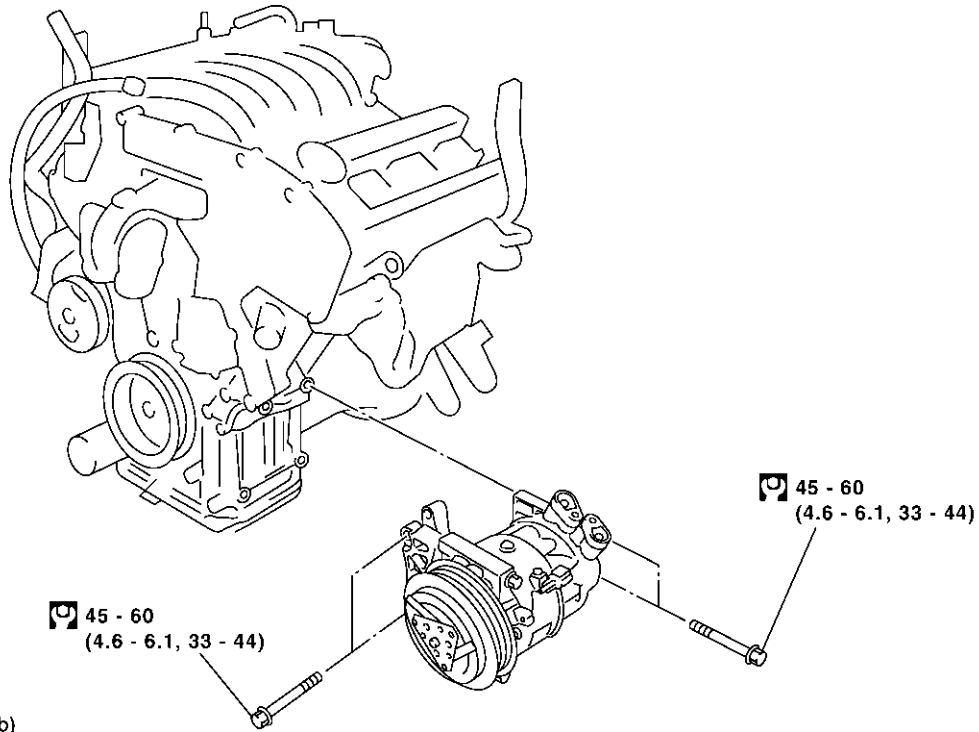

: N·m (kg-m, ft-lb)

CAUTION:
Do not remove the compressor bracket from the compressor.

RHA0621

GI
MA
EM
LC
EC
FE
CL
MT
AT
AX
SU

Compressor Clutch OVERHAUL

NFHA0097

SEC. 274

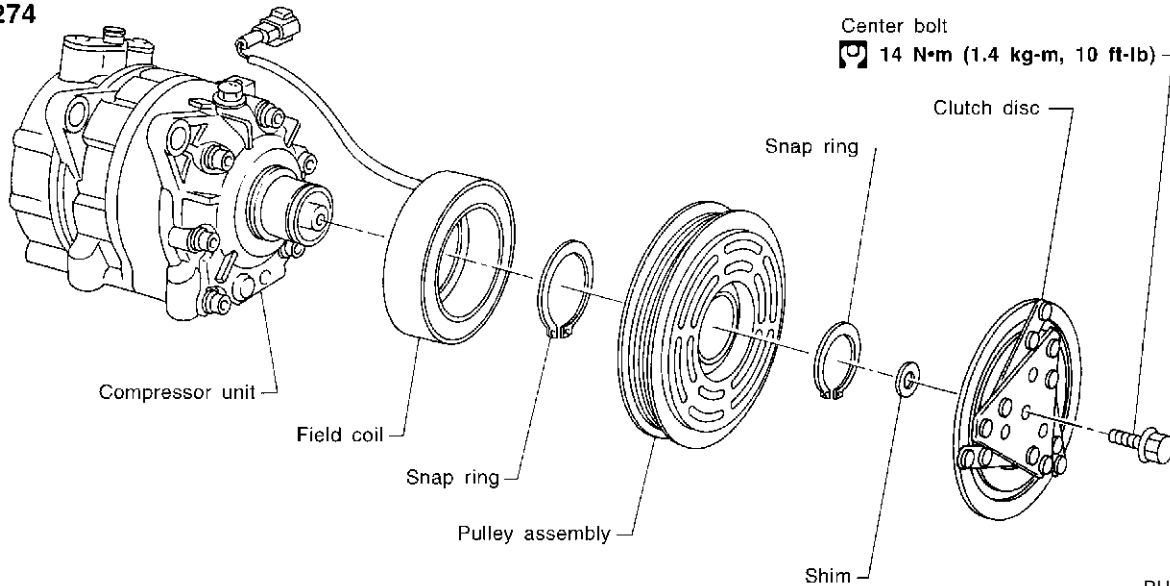

RHA122F

RS
BT
HA
SC
EL
IDX

Compressor Clutch (Cont'd)

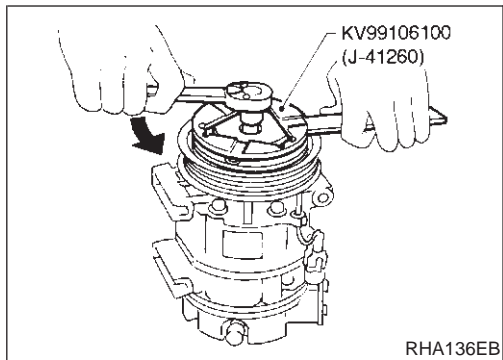

REMOVAL

- When removing center bolt, hold clutch disc with clutch disc wrench. NFHA0098

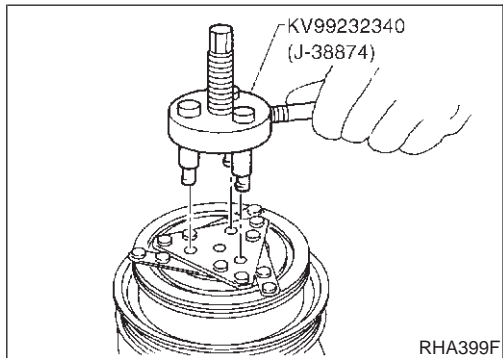

- Remove the clutch disc using the clutch disc puller. Insert the holder's three pins into the holes in the clutch disc. Rotate the holder clockwise to hook it onto the plate. Then, tighten the center bolt to remove the clutch disc. After removing the clutch disc, remove the shims from either the drive shaft or the clutch disc.

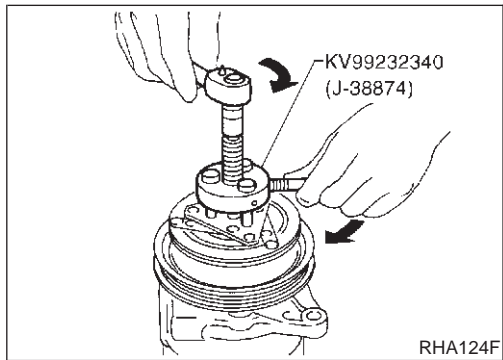

- Remove the snap ring using external snap ring pliers.

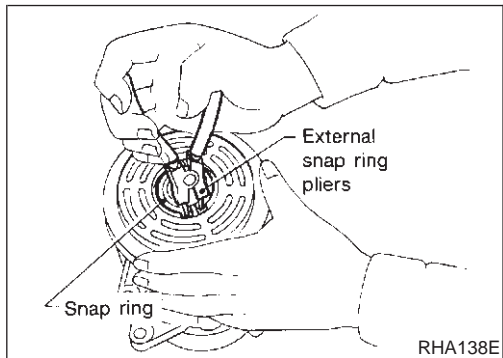

- Pulley removal
Position the center pulley puller on the end of the drive shaft, and remove the pulley assembly using any commercially available pulley puller.
To prevent the pulley groove from being deformed, the puller claws should be positioned onto the edge of the pulley assembly.

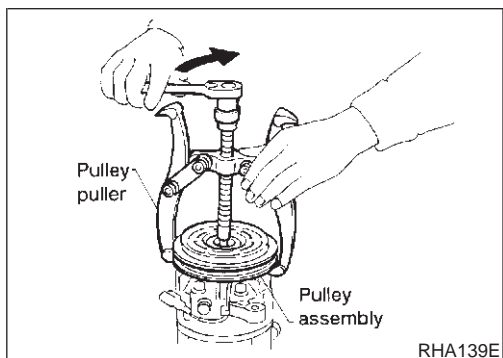

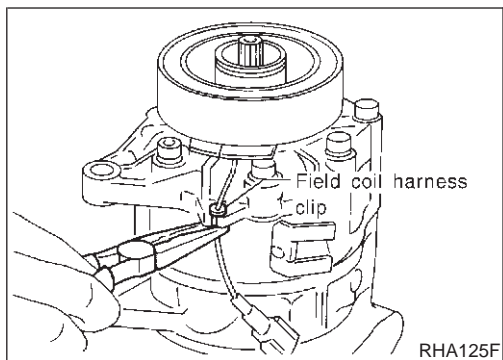

- Remove the field coil harness clip using a pair of pliers.

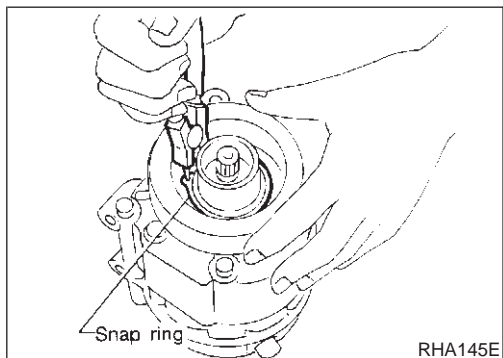

- Remove the snap ring using external snap ring pliers.

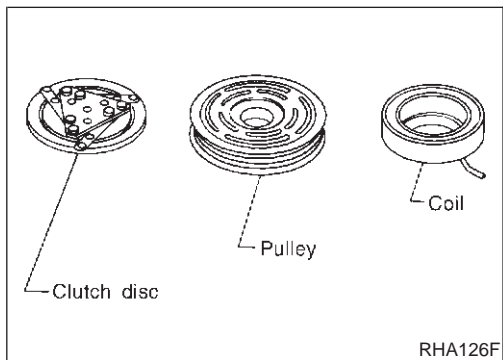

INSPECTION

Clutch Disc

NFHA0099

If the contact surface shows signs of damage due to excessive heat, replace clutch disc and pulley.

NFHA0099S01

Pulley

NFHA0099S02

Check the appearance of the pulley assembly. If the contact surface of pulley shows signs of excessive grooving, replace clutch disc and pulley. The contact surfaces of the pulley assembly should be cleaned with a suitable solvent before reinstallation.

Coil

NFHA0099S03

Check coil for loose connection or cracked insulation.

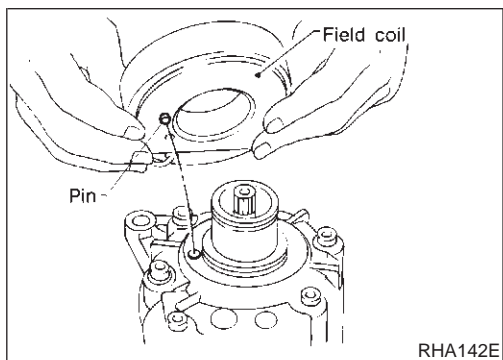

INSTALLATION

NFHA0100

- Install the field coil.
Be sure to align the coil's pin with the hole in the compressor's front head.
- Install the field coil harness clip using a screwdriver.

GI

MA

EM

LC

EC

FE

CL

MT

AT

AX

SU

BR

ST

RS

BT

HA

SC

EL

IDX

Compressor Clutch (Cont'd)

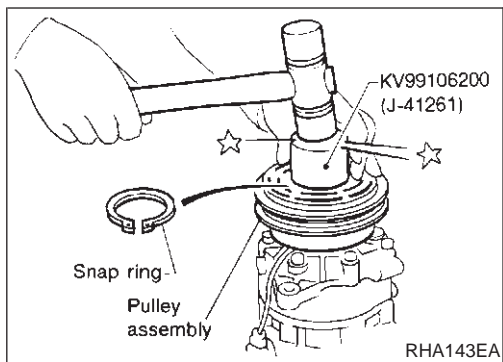

- Install the pulley assembly using the installer and a hand press, and then install the snap ring using snap ring pliers.

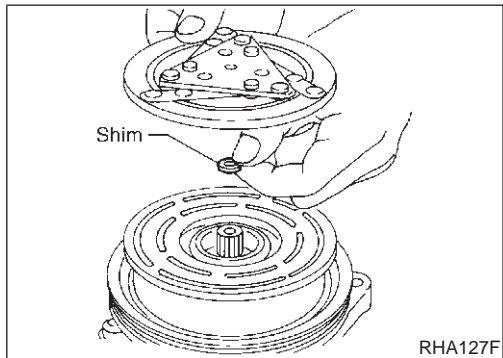

- Install the clutch disc on the drive shaft, together with the original shim(s). Press the clutch disc down by hand.

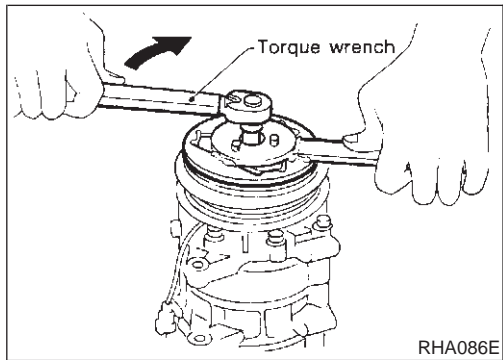

- Using the holder to prevent clutch disc rotation, tighten the bolt to 14 N·m (1.4 kg·m, 10 ft·lb) torque. **After tightening the bolt, check that the pulley rotates smoothly.**

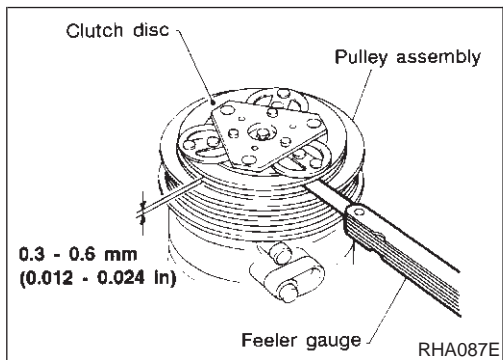

- Check clearance around the entire periphery of clutch disc. **Disc-to-pulley clearance: 0.3 - 0.6 mm (0.012 - 0.024 in)**
If the specified clearance is not obtained, replace adjusting spacer and readjust.

Break-in Operation

When replacing compressor clutch assembly, always carry out the break-in operation. This is done by engaging and disengaging the clutch about thirty times. Break-in operation raises the level of transmitted torque.

NFHA0100S01

Heater Unit (Heater Core) REMOVAL

NFHA0261

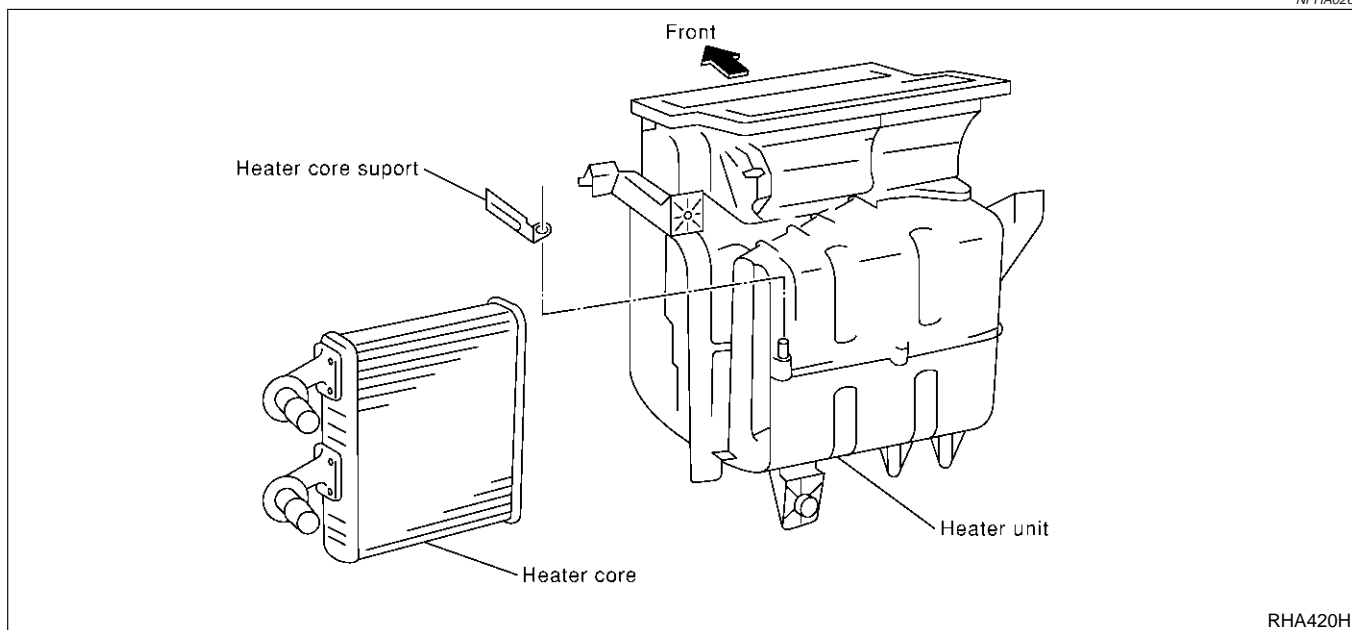

RHA420H

1. Drain the cooling system. Refer to MA-14, "Changing Engine Coolant".
2. Disconnect the two heater hoses from inside the engine compartment.
3. Remove the blower and cooling unit. Refer to HA-236.
4. Remove the steering member assembly. Refer to BT-29, "Removal and Installation".
5. Remove the heater unit.
6. Remove the heater core.

INSTALLATION

NFHA0262

Installation is basically the reverse order of removal.

When filling radiator with coolant, refer to MA-14, "Changing Engine Coolant".

GI

MA

EM

LC

EC

FE

CL

MT

AT

AX

SU

BR

ST

RS

BT

HA

SC

EL

IDX

**Blower and Cooling Unit (A/C Evaporator)
REMOVAL**

NFHA0263

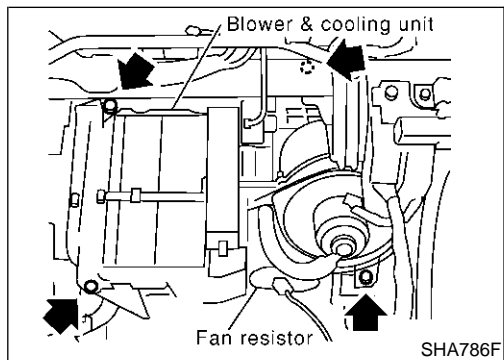
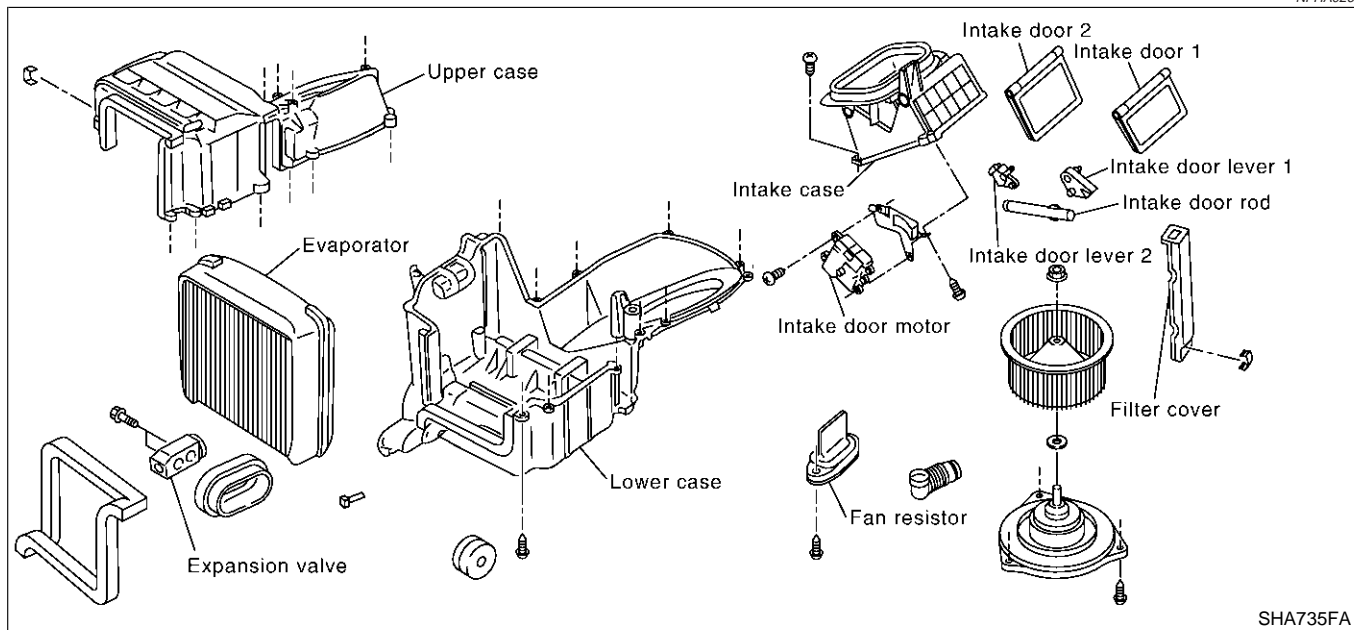

1. Discharge and recover refrigerant from the A/C system. Refer to HA-225.
2. Disconnect the low-pressure and high-pressure lines from the engine compartment. Cap the A/C lines to prevent moisture from entering the A/C system.
3. Remove the glove box and mating trim. Refer to BT-29, "Removal and Installation".
4. Disconnect the fan resistor and blower motor connector.
5. Remove the blower and cooling unit.
6. Separate the blower and cooling unit case, and remove the evaporator.

INSTALLATION

Installation is basically the reverse order of removal.
Recharge the A/C system. Refer to HA-225.

NFHA0264

Refrigerant Lines

REMOVAL AND INSTALLATION

=NFHA0101

- Refer to page HA-159 regarding "Precautions for Refrigerant Connection".

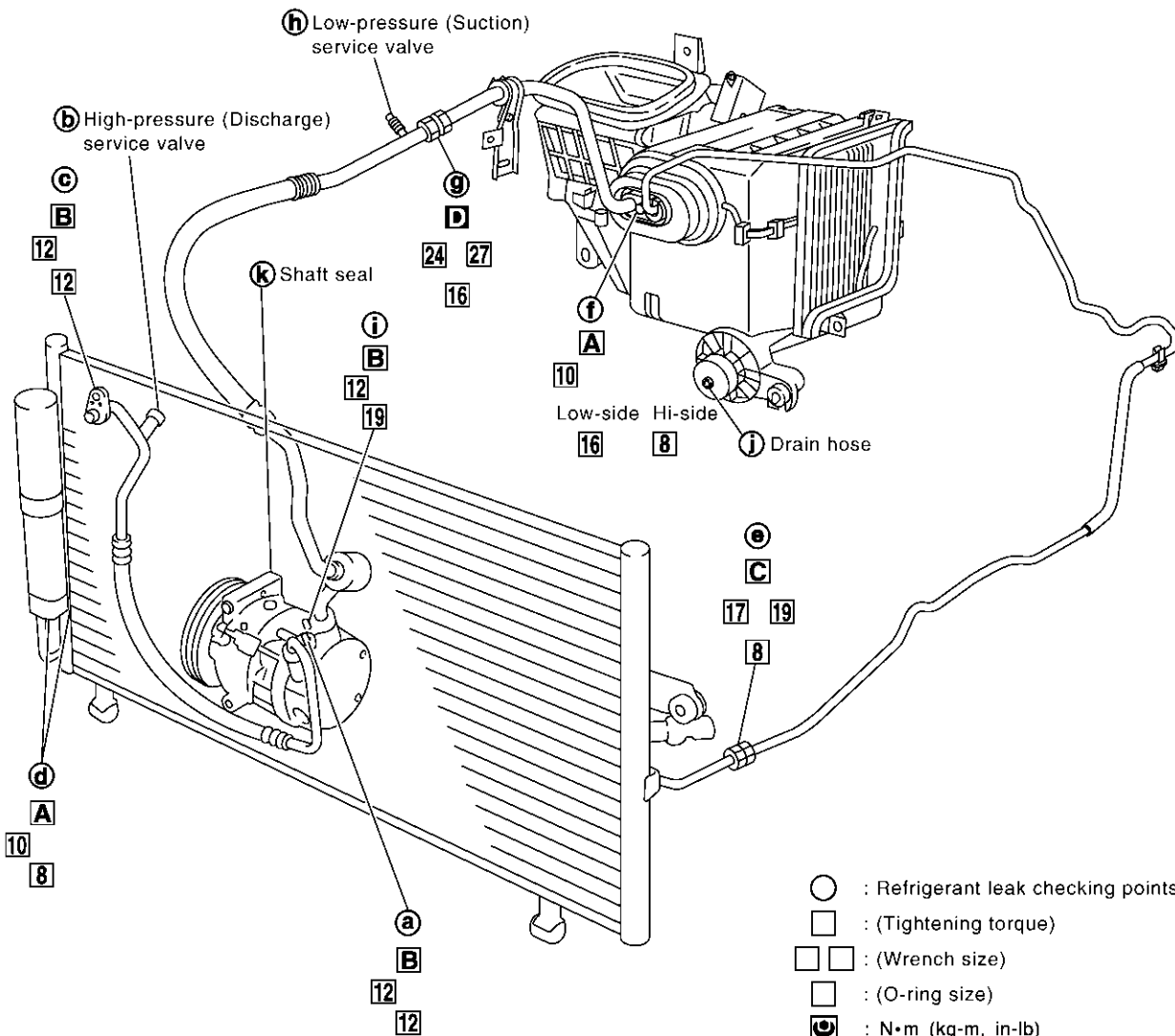

- : Refrigerant leak checking points
- : (Tightening torque)
- □ : (Wrench size)
- : (O-ring size)
- ⊙ : N•m (kg-m, in-lb)
- A** : 2.9 - 5.9 (0.29 - 0.61, 26 - 52)
- B** : 7.8 - 19.6 (0.78 - 2.00, 68 - 173)
- C** : 9.8 - 19.6 (1.00 - 2.00, 87 - 173)
- ⊙ : N•m (kg-m, ft-lb)
- D** : 15 - 24 (1.5 - 2.4, 11 - 18)

GI
MA
EM
LC
EC
FE
CL
MT
AT
AX
SU
BR
ST
RS
BT
HA
SC
EL
IDX

SHA625F

CHECKING REFRIGERANT LEAKS

=NFHA0102

Preliminary Check

NFHA0102S01

- Perform a visual inspection of all refrigeration parts, fittings, hoses, and components for signs of A/C lubricant leakage, damage and corrosion. Take note of the areas with A/C lubricant leakage to allow extra time in these areas with electronic leak detector.
- If dye is observed, confirm the leak with an electronic refrigerant leak detector. It is possible a prior leak was repaired and not properly cleaned.
- When searching for leaks, do not stop when one leak is found but continue to check for additional leaks at all system components and connections.
- When searching for refrigerant leaks using an electronic leak detector, move the probe along the suspected leak area at 1 to 2 inches per second and no further than 1/4 inch from the component.

NOTE:

Moving the electronic leak detector probe slower and closer to the suspected leak area will improve the chances of finding a leak.

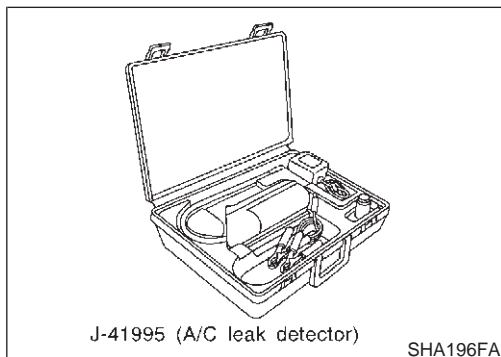

J-41995 (A/C leak detector)

SHA196FA

ELECTRONIC REFRIGERANT LEAK DETECTOR

NFHA0278

Precautions for Handling Leak Detector

NFHA0278S01

When performing a refrigerant leak check, use a J-41995 A/C leak detector or equivalent. Ensure that the instrument is calibrated and set properly per the operating instructions.

The leak detector is a delicate device. In order to use the leak detector properly, read the operating instructions and perform any specified maintenance.

Other gases in the work area or substances on the A/C components, for example, anti-freeze, windshield washer fluid, solvents and lubricants, may falsely trigger the leak detector. Make sure the surfaces to be checked are clean. Clean with a dry cloth or blow off with shop air. Do not allow the sensor tip of the detector to contact with any substance. This can also cause false readings and may damage the detector.

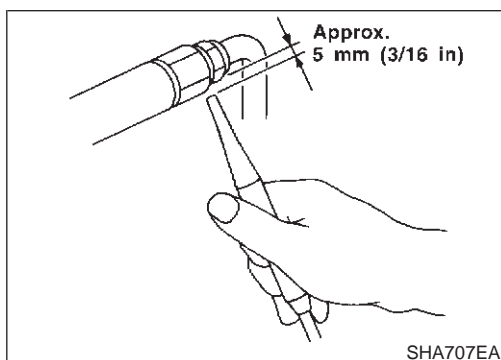

Approx.
5 mm (3/16 in)

SHA707EA

1. Position probe approximately 5 mm (3/16 in) away from point to be checked.

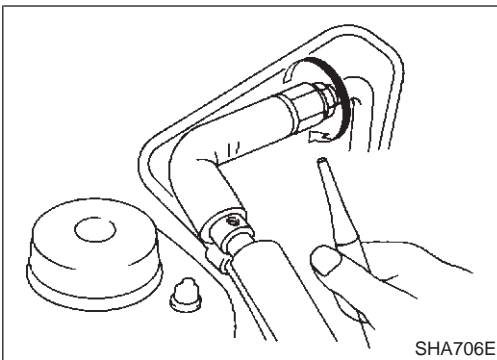

2. When testing, circle each fitting completely with probe.

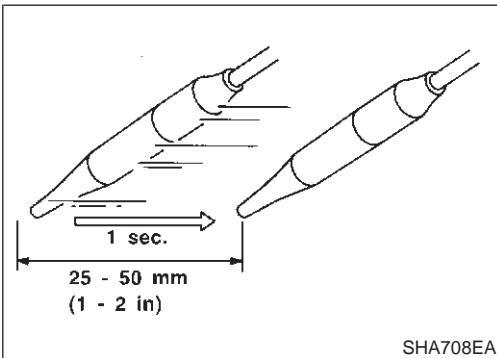

3. Move probe along component approximately 25 to 50 mm (1 to 2 in)/sec.

GI
MA
EM
LC
EC
FE
CL
MT

Checking Procedure

NFHA0278S02

To prevent inaccurate or false readings, make sure there is no refrigerant vapor, shop chemicals, or cigarette smoke in the vicinity of the vehicle. Perform the leak test in calm area (low air/wind movement) so that the leaking refrigerant is not dispersed.

AT
AX
SU
BR
ST

1. Turn engine off.
2. Connect a suitable A/C manifold gauge set to the A/C service ports.
3. Check if the A/C refrigerant pressure is at least 345 kPa (3.52 kg/cm², 50 psi) above 16°C (61°F). If less than specification, recover/evacuate and recharge the system with the specified amount of refrigerant.

NOTE:

At temperatures below 16°C (61°F), leaks may not be detected since the system may not reach 345 kPa (3.52 kg/cm², 50 psi).

RS
BT

4. Conduct the leak test from the high side (compressor discharge **a** to evaporator inlet **f**) to the low side (evaporator discharge **f** to shaft seal **k**). Refer to HA-237. Perform a leak check for the following areas carefully. Clean the component to be checked and move the leak detector probe completely around the connection/component.

HA

- **Compressor**
Check the fitting of high and low pressure hoses, relief valve and shaft seal.
- **Liquid tank**
Check the tube fitting.
- **Service valves**
Check all around the service valves. Ensure service valve caps are secured on the service valves (to prevent leaks).

SC
EL
IDX

NOTE:

After removing A/C manifold gauge set from service valves, wipe any residue from valves to prevent any false readings by leak detector.

- **Cooling unit (Evaporator)**

With engine OFF, turn blower fan on "High" for at least 15 seconds to dissipate any refrigerant trace in the cooling unit. Wait a minimum of 10 minutes accumulation time (refer to the manufacturer's recommended procedure for actual wait time) before inserting the leak detector probe into the drain hose. Keep the probe inserted for at least ten seconds. Use caution not to contaminate the probe tip with water or dirt that may be in the drain hose.

5. If a leak detector detects a leak, verify at least once by blowing compressed air into area of suspected leak, then repeat check as outlined above.
6. Do not stop when one leak is found. Continue to check for additional leaks at all system components. If no leaks are found, perform steps 7 - 10.
7. Start engine.
8. Set the heater A/C control as follows:
 - 1) A/C switch ON.
 - 2) Face mode
 - 3) Recirculation switch ON
 - 4) Max cold temperature
 - 5) Fan speed high
9. Run engine at 1,500 rpm for at least 2 minutes.
10. Turn engine off and perform leak check again following steps 4 through 6 above.

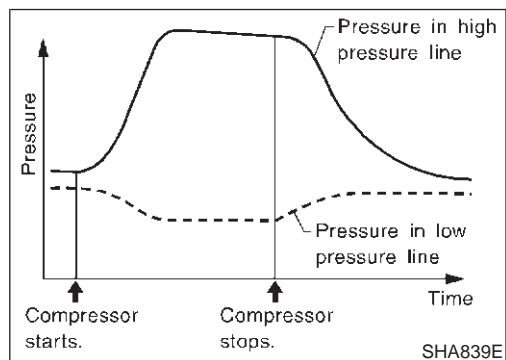

Refrigerant leaks should be checked immediately after stopping the engine. Begin with the leak detector at the compressor. The pressure on the high pressure side will gradually drop after refrigerant circulation stops and pressure on the low pressure side will gradually rise, as shown in the graph. Some leaks are more easily detected when pressure is high.

11. Before connecting ACR4 to vehicle, check ACR4 gauges. No refrigerant pressure should be displayed. If pressure is displayed, recover refrigerant from equipment lines and then check refrigerant purity.
12. Confirm refrigerant purity in supply tank using ACR4 and refrigerant identifier.
13. Confirm refrigerant purity in vehicle A/C system using ACR4 and refrigerant identifier.
14. Discharge A/C system using approved refrigerant recovery equipment. Repair the leaking fitting or component as necessary.

15. Evacuate and recharge A/C system and perform the leak test to confirm no refrigerant leaks.
16. Conduct A/C performance test to ensure system works properly.

GI

MA

EM

LG

Fluorescent Dye Leak Detector

PRECAUTIONS FOR FLUORESCENT DYE LEAK DETECTION

- The fluorescent dye leak detector is not a replacement for an electronic refrigerant leak detector. The fluorescent dye leak detector should be used in conjunction with an electronic refrigerant leak detector (J-41995) to pinpoint refrigerant leaks.
- For your safety and your customer's satisfaction, read and follow all manufacturer's operating instructions and precautions prior to performing the work.
- Refer to "Precautions for Leak Detection Dye", HA-158.

NFHA0279

EC

FE

CL

MT

CHECKING SYSTEM FOR LEAKS USING THE FLUORESCENT LEAK DETECTOR

1. Check A/C system for leaks using the UV lamp and goggles (J-42220) in a low sunlight area (area without windows preferable). Illuminate all components, fittings and lines. The dye will appear as a bright green/yellow area at the point of leakage. Fluorescent dye observed at the evaporator drain opening indicates an evaporator core assembly (tubes, core or TXV) leak.
2. If the suspected area is difficult to see, use an adjustable mirror or wipe the area with a clean shop rag or cloth, then check the cloth with the UV lamp for dye residue.
3. Confirm any suspected leaks with an approved electronic refrigerant leak detector.
4. After the leak is repaired, remove any residual dye using dye cleaner (J-43872) to prevent future misdiagnosis.
5. Perform a system performance check and verify the leak repair with an approved electronic refrigerant leak detector.

NFHA0280

AT

AX

SU

BR

ST

RS

DYE INJECTION

(This procedure is only necessary when re-charging the system or when the compressor has seized and was replaced.)

Refer to "Precautions for Leak Detection Dye", HA-158.

1. Check A/C system static (at rest) pressure. Pressure must be at least 345 kPa (3.52 kg/cm², 50 psi).
2. Pour one bottle (1/4 ounce / 7.4 cc) of the A/C refrigerant dye into the injector tool (J-41459).
3. Connect the injector tool to the A/C LOW PRESSURE side service fitting.
4. Start engine and switch A/C ON.
5. With the A/C operating (compressor running), inject one bottle (1/4 ounce / 7.4 cc) of fluorescent dye through the low-pressure service valve using dye injector tool J-41459 (refer to the manufacturer's operating instructions).

NFHA0281

BT

HA

SC

EL

IDX

- With the engine still running, disconnect the injector tool from the service fitting.

CAUTION:

Be careful not to allow dye to spray or drip when disconnecting the injector from the system.

NOTE:

If repairing the A/C system or replacing a component, pour the dye directly into the open system connection and proceed with the service procedures.

- Operate the A/C system for a minimum of 20 minutes to mix the dye with the system oil. Depending on the leak size, operating conditions and location of the leak, it may take from minutes to days for the dye to penetrate a leak and become visible.

Belt

TENSION ADJUSTMENT

- Refer to MA-13, "Checking Drive Belt".

NFHA0103

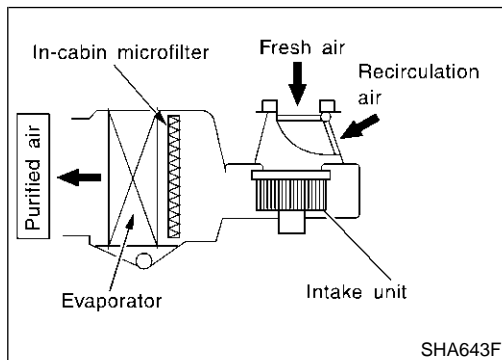

In-cabin Microfilter

FUNCTION

Air inside passenger compartment is kept clean at either recirculation or fresh mode by installing in-cabin microfilter into cooling unit.

NFHA0288

NOTE:

For replacement interval of in-cabin microfilter, refer to "PERIODIC MAINTENANCE", MA-6.

Caution label is fixed inside the glove box.

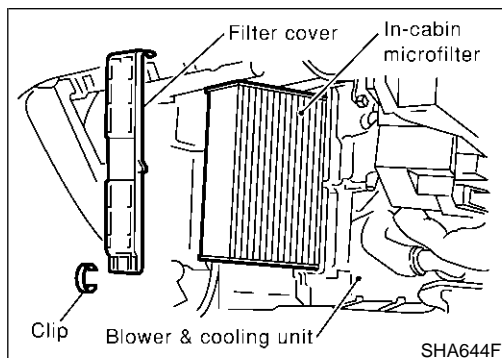

REPLACEMENT PROCEDURE

- Remove glove box.
- Remove instrument lower panel from instrument panel.
- Remove filter cover fixed clip.
- Slide the filter cover to the upper side and then remove it.
- Take out the in-cabin microfilter from cooling unit.
- Replace with new one and reinstall on cooling unit.

NFHA0289

Manual

COMPRESSOR

NFHA0105

Model		Calsonic Kansei make V-6
Type		V-6 variable displacement
Displacement cm ³ (cu in)/rev.	Max.	184 (11.228)
	Min.	14.5 (0.885)
Cylinder bore x stroke mm (in)		37 (1.46) x [2.3 - 28.6 (0.091 - 1.126)]
Direction of rotation		Clockwise (viewed from drive end)
Drive belt		Poly V

GI

MA

EM

LC

EC

LUBRICANT

NFHA0106

Model		Calsonic Kansei make V-6
Name		Nissan A/C System Oil Type S
Part number		KLH00-PAGS0
Capacity mℓ (US fl oz, Imp fl oz)	Total in system	180 (6.1, 6.3)
	Compressor (Service part) charging amount	180 (6.1, 6.3)

FE

CL

MT

REFRIGERANT

NFHA0107

Type	HFC-134a (R-134a)
Capacity kg (lb)	0.5 (1.10)

AT

AX

ENGINE IDLING SPEED (WHEN A/C IS ON)

NFHA0108

- Refer to EC-737, "Idle Speed and Ignition Timing".

SU

BELT TENSION

NFHA0109

- Refer to MA-13, "Checking Drive Belt".

BR

ST

RS

BT

HA

SC

EL

IDX

NOTES